

JBL GH8S

Grand Hybrid Series - Single 18" Passive Subwoofer



JBL GH8S compact subwoofer is a subwoofer system specially designed for KTV party rooms. It has an 18-inch front-loaded subwoofer directing the energy that dancers are looking for. With the adoption of PSL lighting technology, the JBL Entertainment logo illuminates when vibrant music is playing. A switch is provided allowing lighting to be activated. The subwoofer's shrink-in connection feature allows it to be installed against a wall, thereby producing extra SPL.

JBL GH8S is designed with multi-purpose mounting points and features a rotatable logo, allowing for both vertical and horizontal installations to cater to different mounting preferences. In addition, JBL GH8S has one side floor pad, which can facilitate vertical installation.

KEY MESSAGES ■

DESIGNED FOR KTV PARTY ROOMS

JBL GH8S is a power subwoofer that features advanced JBL 460mm ferrite compression driver, delivering distinctive JBL signature sound, with an output power of 1,000W. The solid copper 100mm (4") voice coil is wound in two different layers, supported by inner and outer coils, to integrate double exposure which is beneficial for air cooling. This allows for enhanced long-term heat resistance, and redefines sound to perfectly suit dancing, singing, and DJ.

DURABLE AND RELIABLE

JBL GH8S features a high-end birch cabinet that maintains high power, high dynamics, and ultra-low frequency output, making it ideal for advanced low-frequency response audio reproduction. JBL GH8S 18-inch subwoofer undergoes rigorous stimulation testing and evaluation.

PRACTICAL AND LUXURY DESIGN

The shrink-in back panel design allows for against-wall installation. GH8S provides removable floor pads on the subwoofer bottom and one side. Rotatable JBL logo with PSL technology allows for vertical and horizontal installation. The pole mount system is included to meet mobile demands.

FULL FEATURES ■

- **JBL Transducer.** Advanced JBL 460mm ferrite compression driver delivers distinctive JBL signature sound, with an output power of 1,000W.
- **PSL Lighting Technology.** Enable the JBL Entertainment logo to illuminate when vibrant music is playing, enhancing its modern and stylish appeal.
- **Front-loaded Ventilation.** Allow the speaker to achieve high power output and reduce interference from the back wall.
- **NL4 Neutrik Speakon® Connectors.** Facilitate seamless loop-thru connection of multiple speakers, and achieve system extension with minimal effort.
- **Shrink-in Back Panel Design.** Allow the subwoofer to be installed against a wall, thereby producing extra SPL.
- **Versatile Mounting Options.** Vertical and horizontal installation options cater to different mounting preferences.
- **Rotatable JBL Entertainment logo.** Supports both horizontal and vertical installation.
- **Floor Pads.** 4 pre-installed floor pads are located on the bottom of the subwoofer, providing strong resistance to displacement during high-power playback. An extra floor pad placeholder is provided on one side, allowing the subwoofer to be installed vertically. This provides a flexible option for users to determine how the subwoofer should be placed.

JBL GH8S

Grand Hybrid Series - Single 18" Passive Subwoofer



TECHNICAL SPECIFICATIONS

SYSTEM TYPE

FREQ RANGE (-10dB)¹:	38 Hz - 300 Hz
FREQ RESP (± 3 dB)¹:	44 Hz - 180 Hz
SYSTEM SENSITIVITY (1W @ 1M)¹:	101 dB
NOMINAL IMPEDANCE:	8 ohms
MAX SPL ²:	131 dB continuous average (143 dB peak)
POWER RATING ³ (CONTINUOUS/PROGRAM /PEAK):	1000W / 2000W / 4000W

TRANSDUCERS

LF DRIVER:	460mm (18 in) diameter, 100mm (4 in) voice coil driver
-------------------	--

PHYSICAL

ENCLOSURE:	18 mm birch plywood, fitted with a handle at each side
FINISH:	Duraflex finish
GRILLE:	High-gloss grille surface
INPUT CONNECTOR:	NL4 Neutrik Speakon® in parallel for loop-thru
DIMENSIONS (H X W X D):	546 x 662 x 786 mm
NET WEIGHT:	53.5 kg

FOOTNOTES

- 1: Measurement conducted under half-space (2 π) conditions.
- 2: Peak, unweighted SPL, measured under half-space conditions at 1 meter using broadband pink noise with a 12dB crest factor.
- 3: Testing conducted for 2 hours under pink noise with a crest factor of 6dB, in accordance with IEC standards.

JBL is consistently dedicated to product updates. It integrates new materials, manufacturing processes, or improved designs into existing products without additional notifications. As a result some of the current JBL products may differ from the descriptions provided in product literature. Unless otherwise stated, these updated products perform equivalently or surpass the original design in terms of performance or specifications.

FREQUENCY RESPONSE

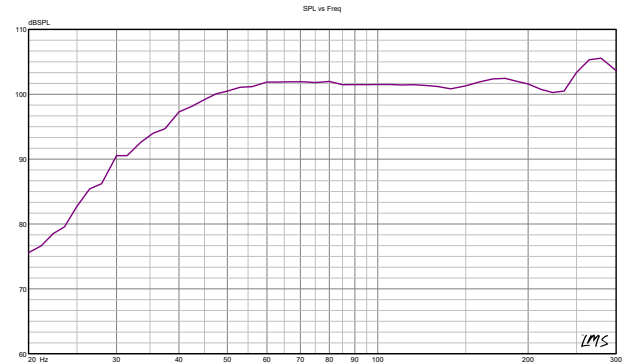

DIMENSIONAL DRAWINGS

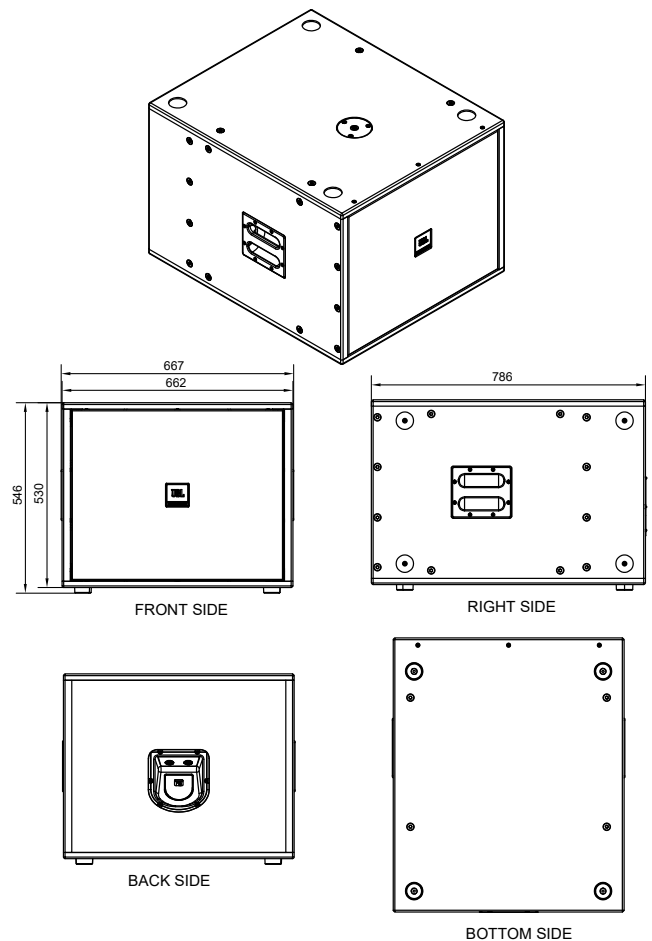

HARMAN Professional 8500 Balboa Blvd. Northridge, CA 91329 USA

© 2023 HARMAN International Industries, Incorporated. All rights reserved. Features, specifications and appearance are subject to change without notice.

www.jblpro.com

Issued: 10/2023