



JBL

PROFESSIONAL

VTX SERIES
SYSTEM SOLUTIONS

VTX B18 | Rigging Manual

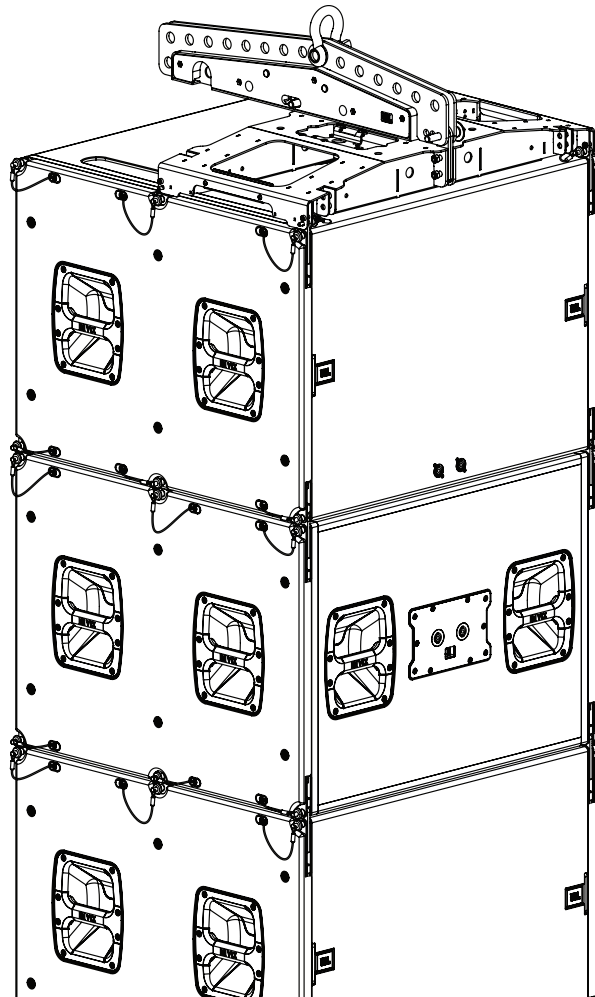

GENERAL INFORMATION

VTX B18 - Rigging Manual

Document Number: 1000337286

Version: D - EN

Distribution Date: July 13, 2023

Copyright © 2023 by HARMAN International; all rights reserved

JBL PROFESSIONAL

8500 Balboa Blvd

Northridge, CA 91329

USA

Thank you for purchasing JBL VTX Series products



In more than 75 years of JBL innovations, the VTX Series stands apart as a milestone in the practical application of creative engineering. VTX products herald the next generation in line array loudspeaker systems: a new era in performance, system integration and user friendliness. VTX products draw on multiple JBL patents in driver, waveguide, and suspension technology, as well as custom amplification, DSP, control, and system management designs created in collaboration with HARMAN Professional sister companies.

VTX loudspeakers marry custom transducer design and in-house manufacture, breakthrough technologies, and a comprehensive system approach to deliver a premium experience for all who come into contact with it, from the FOH mixing engineer to the systems engineer, rigger, road crew, warehouse manager, and, of course, the audience. Designed for operators of portable and fixed systems alike, the VTX Series features JBL's legendary sound quality coupled with expert support and advanced tools that enable optimal specification, configuration, and operation of VTX systems in any venue, anywhere in the world. The VTX Series delivers a comprehensive solution: the finest sound quality available, plus efficient and intuitive setup, tuning, networking, and control.

TABLE OF CONTENTS

1 - DOCUMENT REVISION HISTORY	6
2 - DECLARATION OF CONFORMITY	7
3 - SAFETY	8
3.1 Safety Instructions	8
3.2 General Hardware Information	8
3.3 Attachment to Structures	8
3.4 Important Safety Warning	9
3.5 Are You New to Rigging?	9
3.6 Inspection and Maintenance	9
3.7 Symbols	10
3.8 Resources and Documentation	10
4 - MECHANICAL LIMITS	11
4.1 VTX B18 Limits - Suspended Array	11
5 - SYSTEM COMPONENTS	12
6 - SOFTWARE	14
6.1 Line Array Calculator 3™	14
6.2 Suspended Arrays	15
6.3 Ground-Stacked Arrays	16
7 - RIGGING SYSTEM OVERVIEW	17
7.1 Rigging Closeup	17
7.2 Deploying the Rigging Bars	18
8 - TRANSPORTATION OPTIONS	20
8.1 Rotating the Dolly Tabs For Use With the ACC Dolly	21
8.2 VTX B18 ACC Dolly Overview	23
8.3 Attaching the VTX B18 ACC Dolly	24
8.4 Stacking the ACC Dolly Boards	25
8.5 Truck Packing With the VTX B18 ACC	27
8.6 Installing VTX B18 Cabinets on a VT	29
8.7 Stacking the VTX B18 VT	32
8.8 Truck Packing With the VTX B18 VT	33
9 - SUSPENDING THE VTX B18	34
9.1 Attaching the Array Frame	34
9.2 Suspending B18 Arrays	37
9.3 Connecting Additional B18 Stacks	38

10 - THE VTX A8 SUSPENSION BAR	40
10.1 Suspension Bar Overview	40
10.2 Suspension Bar Attachment Tabs	41
10.3 Attaching the Suspension Bar	42
10.4 Suspension Bar Use Cases	43
10.5 Using the VTX A8 SB for Pull-Back	44
10.6 Pull-Back Use Cases	45
11 - THE VTX A8 MINI FRAME	46
11.1 Mini Frame Overview	46
11.2 Attaching the Mini Frame	47
11.3 Mini Frame Suspension Options	49
11.4 Selecting Spreader Bar Positions	50
11.5 Mini Frame and RC500	51
12 - M20 POLE MOUNT ATTACHMENT	52
13 - SPECIFICATIONS	53
13.1 VTX A8 AF	53
13.2 VTX A8 AF EB	54
13.3 VTX A8 MF	55
13.4 VTX A8 SB	56
13.5 VTX B18 VT	57
13.6 VTX B18 ACC	58
13.7 - VTX B1 GND	59
14 - CONTACT INFORMATION	60

1 - DOCUMENT REVISION HISTORY

VERSION	RELEASE DATE	CHANGES
Version A	November 25, 2018	<ul style="list-style-type: none">• Initial VTX B18 Rigging Manual
Version B	January 5, 2019	<ul style="list-style-type: none">• Updated Mechanical Limits section• Added Suspension Bar configuration examples• Added pull-back use-case section• Added the VTX A8 MF section (page 43)• Added RC500 examples
Version C	January 25, 2021	<ul style="list-style-type: none">• Updated the LAC-3 section• Added pole mount section• Minor formatting updates
Version D	July 13, 2023	<ul style="list-style-type: none">• Update the LAC-3 section• Added the VTX B1 GND to the list of supported accessories• Added Resource and Documentation section• Updated the Contact Information section

2 - DECLARATION OF CONFORMITY

BRAND: JBL Professional

FAMILY NAME: VTX A8/B18 loudspeaker and suspension accessories

MODEL NAMES:

- VTX A8
- VTX A8 AF
- VTX A8 AF EB
- VTX A8 MF
- VTX A8 SB
- VTX A8 BP
- VTX RC500
- VTX A8 VT
- VTX B18
- VTX B18 VT
- VTX B18 ACC

We, HARMAN International, declare under our sole responsibility that the product, to which this declaration relates, is in conformity with the following standards:

STANDARD	DESCRIPTION	TEST AGENCY
2006/42/EC MACHINERY DIRECTIVE	Applies to machinery and lays down essential health and safety requirements. ISO12100	Tested at JBL Professional
2014/35/EC LOW VOLTAGE DIRECTIVE	Applies to loudspeaker and lays down essential health and safety requirements. EN60065	Tested at JBL Professional



Frank Lacelle

Compliance Manager - Harman International

3 - SAFETY

3.1 SAFETY INSTRUCTIONS

1. Read these instructions.
2. Keep these instructions.
3. Heed all warnings.
4. Follow all instructions.
5. Do not expose the product to direct rain or sea spray.
6. Clean only with a dry cloth.
7. Do not install near any heat sources such as radiators, heat registers, stoves, or other apparatus that produce heat.
8. Only use attachments/accessories specified by the manufacturer.
9. Use only with a cart, stand, tripod, bracket, or table specified by the manufacturer or sold with the apparatus. When a cart is used, use caution when moving the cart/apparatus combination to avoid injury from tip-over.
10. Refer all servicing to qualified service personnel. Servicing is required when the apparatus has been damaged in any way, such as if liquid has been spilled or objects have fallen into the apparatus, or if the apparatus has been exposed to rain or moisture, does not operate normally, or has been dropped.
11. Contact JBL Professional for advanced servicing issues.
12. **CAUTION - DO NOT PERFORM ANY SERVICING UNLESS YOU ARE QUALIFIED TO DO SO.**
13. Prolonged exposure to excessive SPL can cause hearing damage. The loudspeaker is easily capable of generating sound pressure levels (SPL) sufficient to cause permanent hearing damage to performers, production crew, and audience members. Caution should be taken to avoid prolonged exposure to SPL in excess of 90 dB.
14. Read the System Rigging Manual before installation and use of the product.

3.2 GENERAL HARDWARE INFORMATION

Any hardware used in an overhead suspension application must be load rated for the intended use. Generally, this type of hardware is available from rigging supply houses, industrial supply catalogs, and specialized rigging distributors. Local hardware stores do not usually stock these products. Compliant hardware will be referenced with a working load limit (WLL) and a traceability code.

3.3 ATTACHMENT TO STRUCTURES

A licensed Professional Engineer must approve the placement and method of attachment to the structure prior to the installation of any overhead object. The following performance standards should be provided to the Professional Engineer for design purposes: Uniform Building Code as applicable, Municipal Building Code as applicable, and Seismic Code as applicable. The installation of the hardware and method of attachment must be carried out in the manner specified by the Professional Engineer. Improper installation may result in damage, injury, or death.

3.4 IMPORTANT SAFETY WARNING

The information in this section has been assembled from recognized engineering data and is intended for informational purposes only. None of the information in this section should be used without first obtaining competent advice with respect to applicability to a given circumstance. None of the information presented herein is intended as a representation or warranty on the part of JBL. Anyone making use of this information assumes all liability arising from such use.

All information presented herein is based upon materials and practices common to North America and may not directly apply to other countries because of differing material dimensions, specifications, and/or local regulations. Users in other countries should consult with appropriate engineering and regulatory authorities for specific guidelines.

Correct use of all included hardware is required for secure system suspension. Careful calculations should always be performed to ensure that all components are used within their working load limits before the array is suspended. Never exceed the maximum recommended load ratings.

Before suspending any speaker system, always inspect all components (enclosure, rigging frames, pins, eyebolts, track fittings, etc.) for cracks, deformations, corrosion, or missing/loose/damaged parts that could reduce strength and safety of the array. Do not suspend the speaker until the proper corrective action has been taken. Use only load-rated hardware when suspending JBL suspendable loudspeaker models.

3.5 ARE YOU NEW TO RIGGING?

If you are new to rigging, you should:

- Know the rules for safe rigging.
- Attend a safe rigging seminar.
- Meet and establish a relationship with a licensed mechanical or structural engineer. Get in the habit of asking them questions instead of assuming their answers. Learn from what they tell you.
- Research and understand the codes, practices and requirements of the venues where you intend to operate your sound system.

3.6 INSPECTION AND MAINTENANCE

Suspension systems are comprised of mechanical devices and, as such, require regular inspection and routine maintenance to ensure proper functionality. Before suspending or pole mounting any speaker system, always inspect all components (enclosure, suspension frames or brackets, pins, eyebolts, etc.) for cracks, deformations, corrosion, or missing/loose/damaged parts that could reduce strength and safety of the array. Do not suspend or pole mount a speaker until the proper corrective action has been taken.

Installed systems should be inspected at least once a year. The inspection must include a visual survey of all corners and load-bearing surfaces for signs of cracking, water damage, delamination, or any other condition that may decrease the strength of the loudspeaker enclosure.

Accessory suspension hardware provided with or for VTX systems must be inspected for fatigue at least once a year or as required by local ordinance. The inspection must include a visual survey of the material for signs of corrosion, bending, or any other condition that may decrease the strength of the fastener. Additionally, any eyebolts must be checked for possible spin-out of the enclosure.

For all other hardware and fittings, refer to the hardware manufacturer's inspection and maintenance guidelines for process.

JBL is not responsible for the application of its products for any purpose or the misuse of this information for any purpose. Furthermore, JBL is not responsible for the abuse of its products caused by avoiding compliance with inspection and maintenance procedures or any other abuse.

Prior to suspending the system, an expert, trained and experienced in suspending speaker systems, should inspect all parts and components.

3.7 SYMBOLS

The following symbols are used in this document:



CAUTION: This symbol gives notice of a potential risk of harm to the individual or the equipment. Instruction marked with this symbol must be strictly followed.



TIP: This symbol gives notice of helpful, relevant information about the topic.



INSTRUCTIONS: This symbol gives notice of instructions that must be followed for proper installation and use of the product.



TOOLS REQUIRED: This symbol gives notice of tools that must be used for proper installation and use of the product.

3.8 RESOURCES AND DOCUMENTATION

Several resources are available to VTX Series owners to illustrate proper and safe use of the equipment. Below is an overview of what is available and a brief description of each resource:

USER MANUAL: This document focuses on the electromechanical aspects of the system, including amplification, wiring, speaker pre-sets, tuning, and optimization. User manuals do not include information regarding rigging and suspension hardware.

RIGGING MANUAL: This document focuses on the mechanical aspects of the system, including step-by-step rigging instructions, accessory usage, mechanical limits, and safety instructions. All users must read this document.

SPECIFICATION SHEETS: These documents include detailed specifications for loudspeakers and accessories. Specifications include acoustical performance, material types, weight, and general mechanical information. Specification sheets are available for each product.

CUSTOMER DRAWINGS: This is a collection of files that includes detailed drawings for each SKU. The collection consists of detailed dimensional 2D PDF/DXF documents and simplified 3D DXF models. Depending on the product, additional types of 3D files might be available for download at www.jblpro.com.

VIDEO TUTORIALS: Software and hardware video tutorials are available for watching on the JBL Professional [YouTube channel](#).

4 - MECHANICAL LIMITS

The VTX B18 suspension system and accessories comply with the 2006/42/EC Machinery Directive and have been designed following the guidelines of BGV-C1 for a minimum safety factor of 4:1. Minimum safety factor requirements are often set by local regulations and the JBL Line Array Calculator-3™ (LAC-3) software should always be used to check mechanical limits.

4.1 VTX B18 LIMITS - SUSPENDED ARRAY

ARRAY FRAME	NOTES	SAFE LIMIT	MAXIMUM LIMIT
VTX A8 AF + EB	VTX A8 AF - Array Frame with Extension Bar attached	(12) B18	(16) B18
VTX A8 SB	(1) Suspension Bar used as an Array Frame (top center)	(16) B18	(16) B18
VTX A8 SB (X2)	(2) Suspension Bars used at the top (front / rear rigging bars)	(10) B18	(16) B18
VTX A8 SB (X2)	(2) Suspension Bars used at the top and bottom (pull-back)	(12) B18	(16) B18
VTX A8 MF	VTX A8 MF - Mini Frame	(4) B18	(4) B18

TERMINOLOGIES:

Safe Limit: The safe limit provides the number of cabinets that can be used in an array and always produce a safety factor of 4:1 or higher. The safety factor of an array is determined by the number of boxes, the array shape, and the overall array angle. A B18 array that is within the safe limit will always yield a safety factor greater than 4:1 regardless of the array parameters and conditions. Designs much greater than the safe limit, and up to the maximum limit can be achieved, but the Line Array Calculator software should be used to check mechanical safety for the given configuration.

Maximum Limit: Arrays larger than the maximum limit are not allowed under any conditions.

NOTES:

- LAC-3 allows for array designs with a minimum design factor of 4:1. Anything lower than that is not allowed
- For exact mechanical limits of combination arrays (A8s suspended under B18s) always check the design with LAC-3
- For mechanical limits when using dual Suspension Bars always check the design with LAC-3
- ANSI Standard E1.8-2005 (Entertainment Technology Loudspeaker Enclosures Intended for Overhead Suspension), Section 5.3.4, specifies a minimum safety factor of 5:1. If compliance with the ANSI standard is needed, make sure that the array design in LAC-3 produces a minimum safety factor of 5:1

5 - SYSTEM COMPONENTS

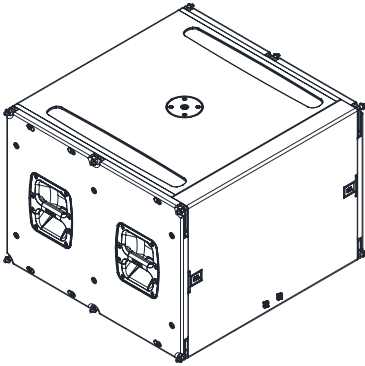

VTX B18

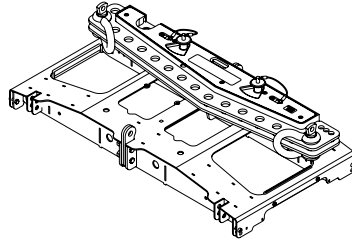

VTX A18 AF | Array Frame

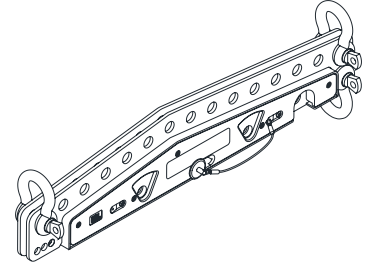

VTX A8 AF EB | Extension Bar

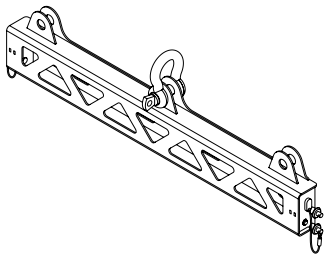

VTX A8 SB | Suspension Bar

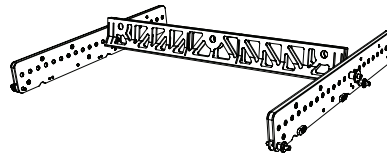

VTX A8 MF | Mini Frame

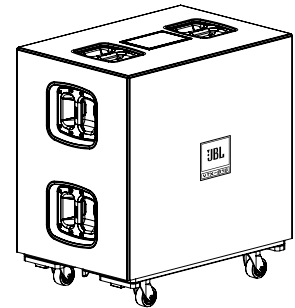

VTX B18 ACC | Dolly Board & Cover

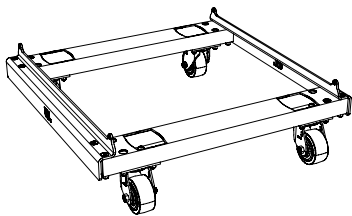

VTX B18 VT | Vertical Transporter

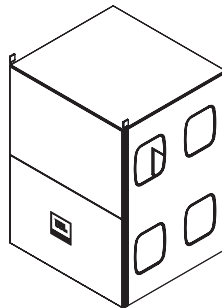

VTX B18 VT CVR | Soft Cover

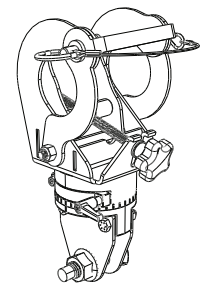

VTX RC500 | Rotating Clamp



CAUTION: Always use components and accessories specified and approved by JBL Professional. When a cart is used, use caution when moving the cart to avoid injury from tip-over.

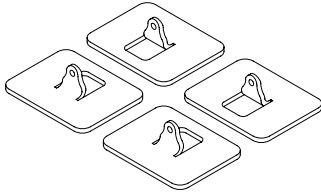

VTX RC500 | Rotating Clamp



CAUTION: Always use components and accessories specified and approved by JBL Professional. When a cart is used, use caution when moving the cart to avoid injury from tip-over.

6 - SOFTWARE

6.1 LINE ARRAY CALCULATOR 3™

Line Array Calculator 3 acoustical prediction software is used for the design and mechanical validation of VTX Series line array systems. Using LAC-3 is a three-step process. First, venue dimensions are defined using either X/Y/Z coordinates or the fast distance/angle method. Second, array configurations are built from VTX Series loudspeaker models. Third, virtual measurement microphones and a suite of built-in DSP functions are applied to make predictions of the system's coverage and the linearity that will be delivered by the defined array configuration in the specified space. Loudspeaker quantities and models, splay angles, and array aiming can be modified until prediction shows that the desired coverage is attained throughout the venue. The built-in coverage-and-delay calculator determines subwoofer delay values for electronic delay steering (EDS) that achieves optimal low frequency coverage.

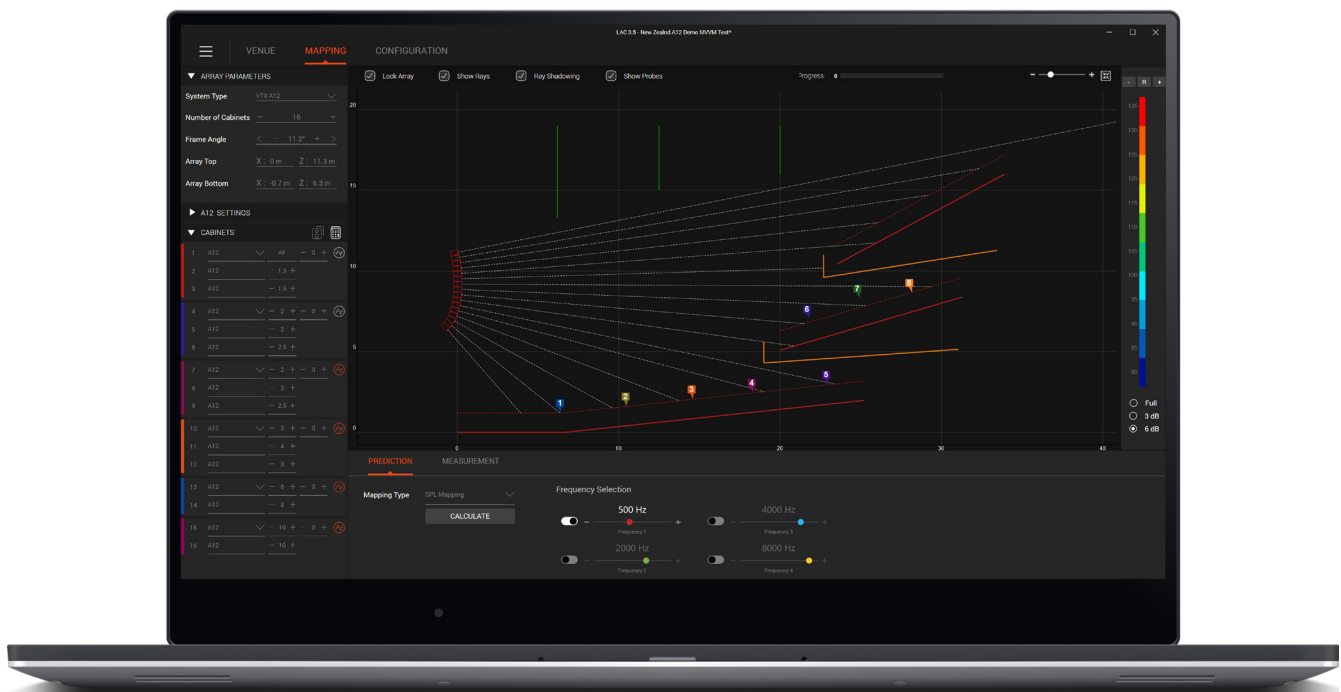

Beyond acoustical predictions, LAC-3 validates the mechanical properties of arrays and selected JBL accessories. Configuration limits are calculated in real time, for either suspended or ground-stacked arrays, based on array parameters such as the number of cabinets, cabinet-to-cabinet splay angles, overall array aiming, and selected accessories. In the case of suspended arrays, a safety factor is calculated to aid in designing systems that conform to local regulations. Warnings and error messages notify the user when an array or a specific accessory is outside safe working limits. For ground-stacked arrays, a tipping factor calculated from a complex set of variables suggests whether an array design is likely to be stable, potentially unstable, or unsafe. Array statistics like array size, depth, and weight are also calculated, and a PDF report facilitates system deployment. Mechanical data can be transferred to JBL's Array Link™ app running on an iOS® or Android™ mobile phone using a QR code, with no need for internet connectivity. All relevant rigging information and options are presented in an easy-to-understand layout.



CAUTION: All VTX systems should be designed and validated using the LAC-3 software application. This is the only way to ensure that safe mechanical conditions are met for any given configuration.

6.2 SUSPENDED ARRAYS

Line Array Calculator 3 checks the mechanical safety of suspended arrays and takes into consideration all variables that can affect the mechanical safety and safety factors. The software validates the mechanical stresses on the enclosures, speaker rigging components, and all accessories used as part of an array. Parameters like array down angle and curvature are considered and a safety factor is generated for the given configuration. The generated safety factor value represents the minimum of any components used, and values are always rounded down.

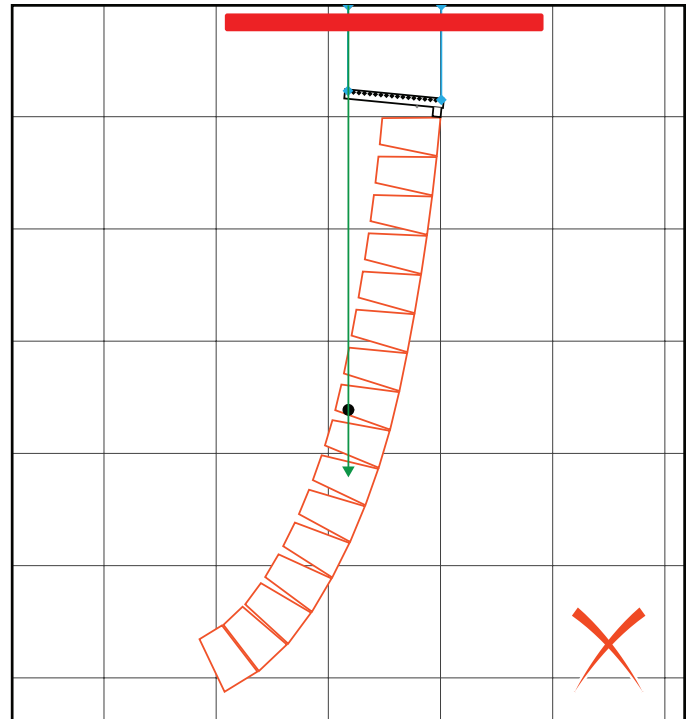
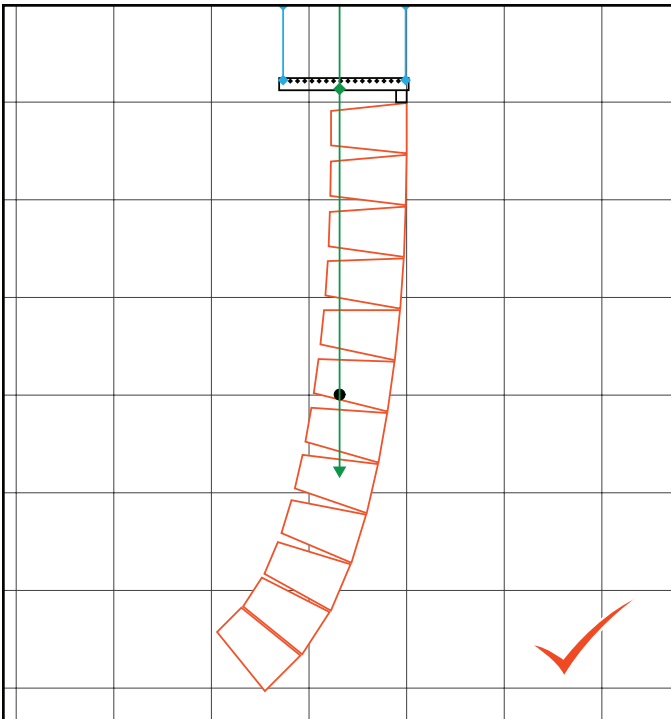

A red banner appears at the top of the array views when the software detects a mechanical error. The banner explains the issue, and some configurations might include more than one error. In that case, the software will present the additional messages as the errors are cleared. Configurations generating a mechanical error should never be used, as their safety factor falls under the minimum of 4:1. The safety factor generated by the application can be used to design arrays with safety factors other than 4:1 and based on local regulations.

In addition to mechanical and safety errors, the software notifies of configurations that cannot be realized in real life. An example of such a condition is when the center of gravity of an array falls outside of the footprint of the array frame. In this case, the error can be cleared by changing the down angle or using a pull-back at the bottom of the array.

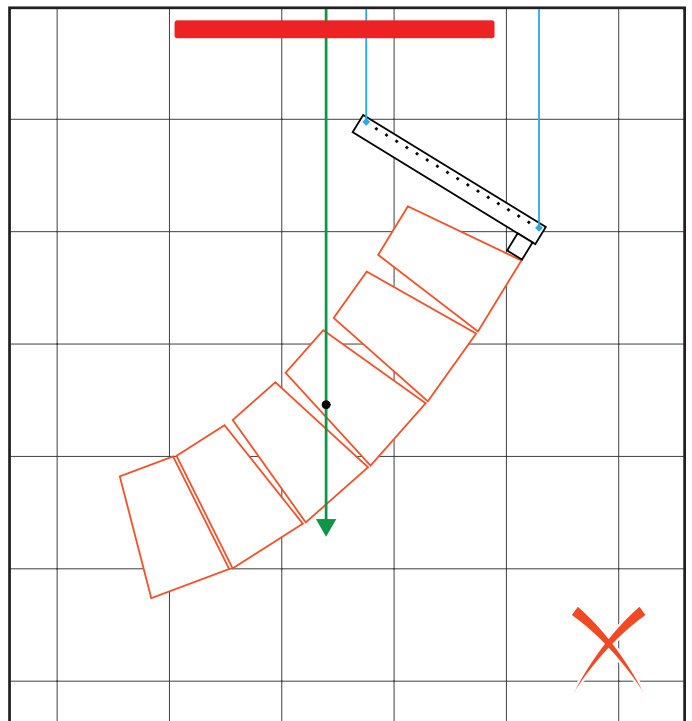

- Center of Gravity
- Suspension Points

6.3 GROUND-STACKED ARRAYS

Line Array Calculator 3 checks for the mechanical safety of ground-stacked arrays. The software takes into consideration several variables that can affect the stability of an array, including outside factors such as someone pushing on an array. Based on this data, LAC-3 generates a safety assessment factor and notifies the user of potential mechanical or stability problems. Errors and warnings generated fall into one of the following categories:

No errors or messages

In this case, the array is stable under normal conditions and can be used as is. The array also complies with the mechanical limits set by JBL for the speakers and selected accessories.

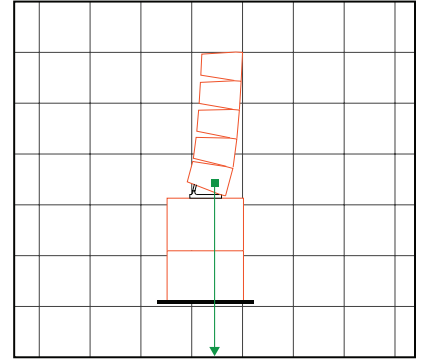

WARNING: Stability Hazard! - Stack Could Become Unstable - Secure to Ground

This message is an alert that the array is potentially unstable and a tipping hazard condition has been detected. The user is responsible for securing the array to the ground, stage, or other structure that can provide additional support and is rated for the weight of the array. This message may also be warning of external factors that can influence stability, such as someone accidentally pushing the array.

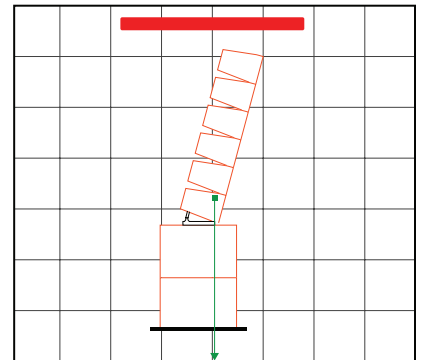

Configuration exceeds the maximum number of boxes allowed

This message is presented when the specified array design exceeds the mechanical limits set by the JBL team for the speakers or selected accessories. Array designs that trigger this message should not be used under any conditions, as they can lead to hardware damage and/or injury.

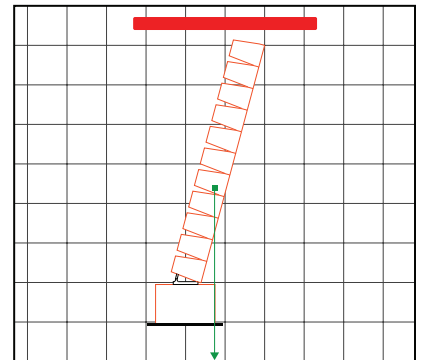

Invalid CG Location

This message is presented when the center of gravity of an array design exceeds the footprint of the selected accessory. Array designs that trigger this message should not be used under any conditions, as they can lead to hardware damage and/or injury.

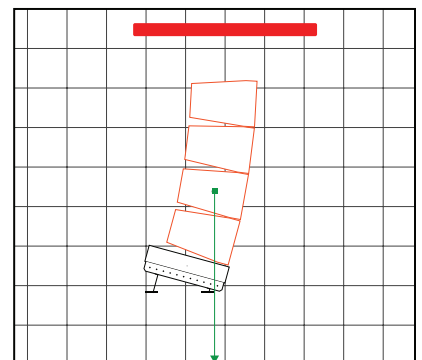

● Center of Gravity

7 - RIGGING SYSTEM OVERVIEW

VTX B18 cabinets include a six-point, spring-loaded, rigging mechanism that is easy to use and can be deployed to suspend up to 16 B18 cabinets, depending on the configuration. The B18 rigging system enables forming either standalone B18 arrays or mixed arrays using VTX A8 full-range cabinets suspended under the B18s. All VTX A8 suspension accessories, such as the Array Frame, Suspension Bar, and Mini Frame are compatible with the B18. When used in ground-stacked configurations, the spring-loaded rigging mechanism maintains tension on all parts, preventing any audible artifacts from vibrations. The B18 rigging system and enclosure are front-to-back symmetric, enabling cardioid arrays to be easily created for suspension or ground stacking.

7.1 RIGGING CLOSEUP

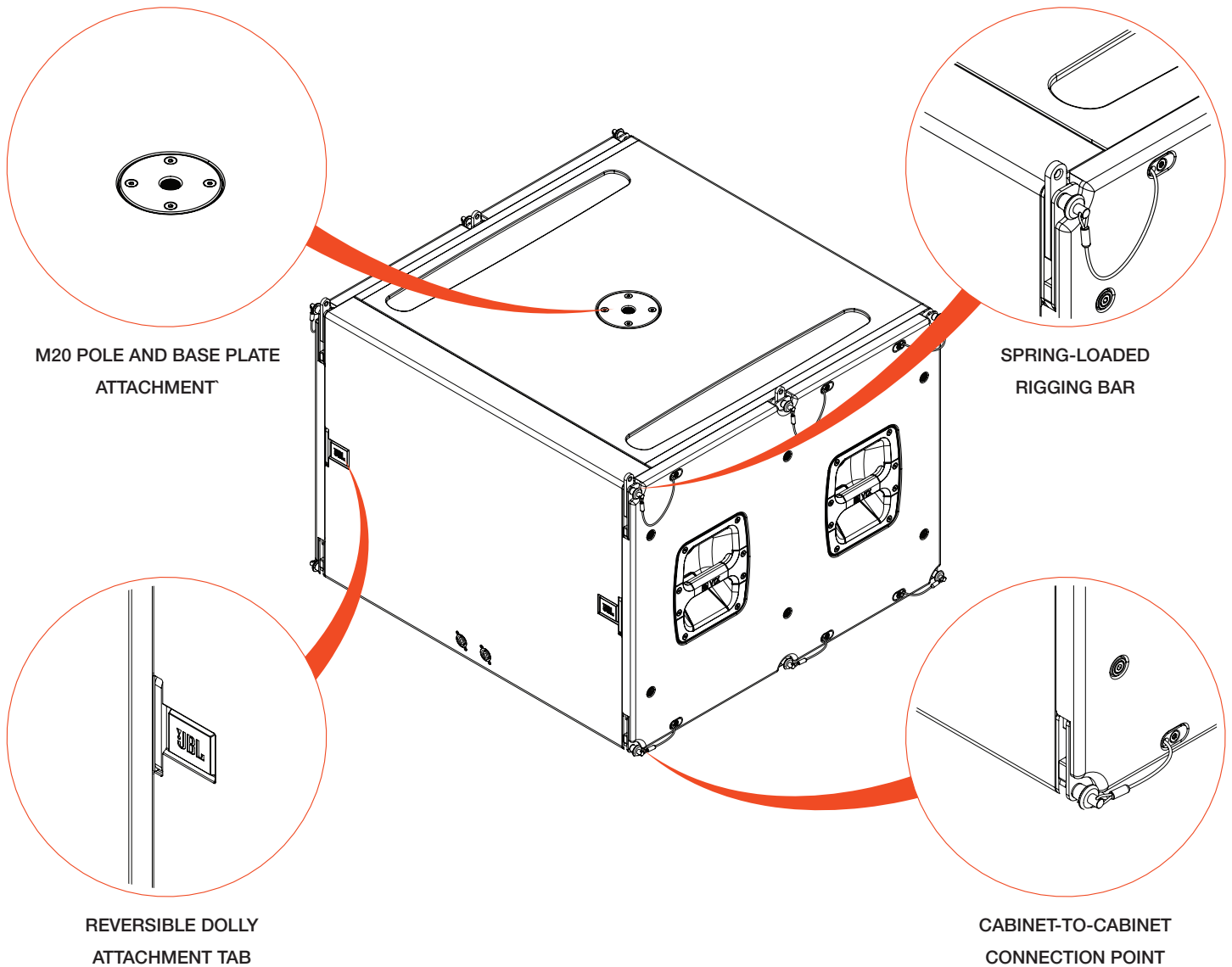

7.2 DEPLOYING THE RIGGING BARS

Each of the six B18 rigging bars incorporates a spring-loaded mechanism. A bar automatically extends upwards once its quick release pin (QRP) is removed. The same QRP secures the bar in place after it has been deployed.

STEPS:

- 1 Temporarily remove the quick release pin for each position
- 2 The rigging bar automatically extends upwards
- 3 Return the quick release pins to their storage positions

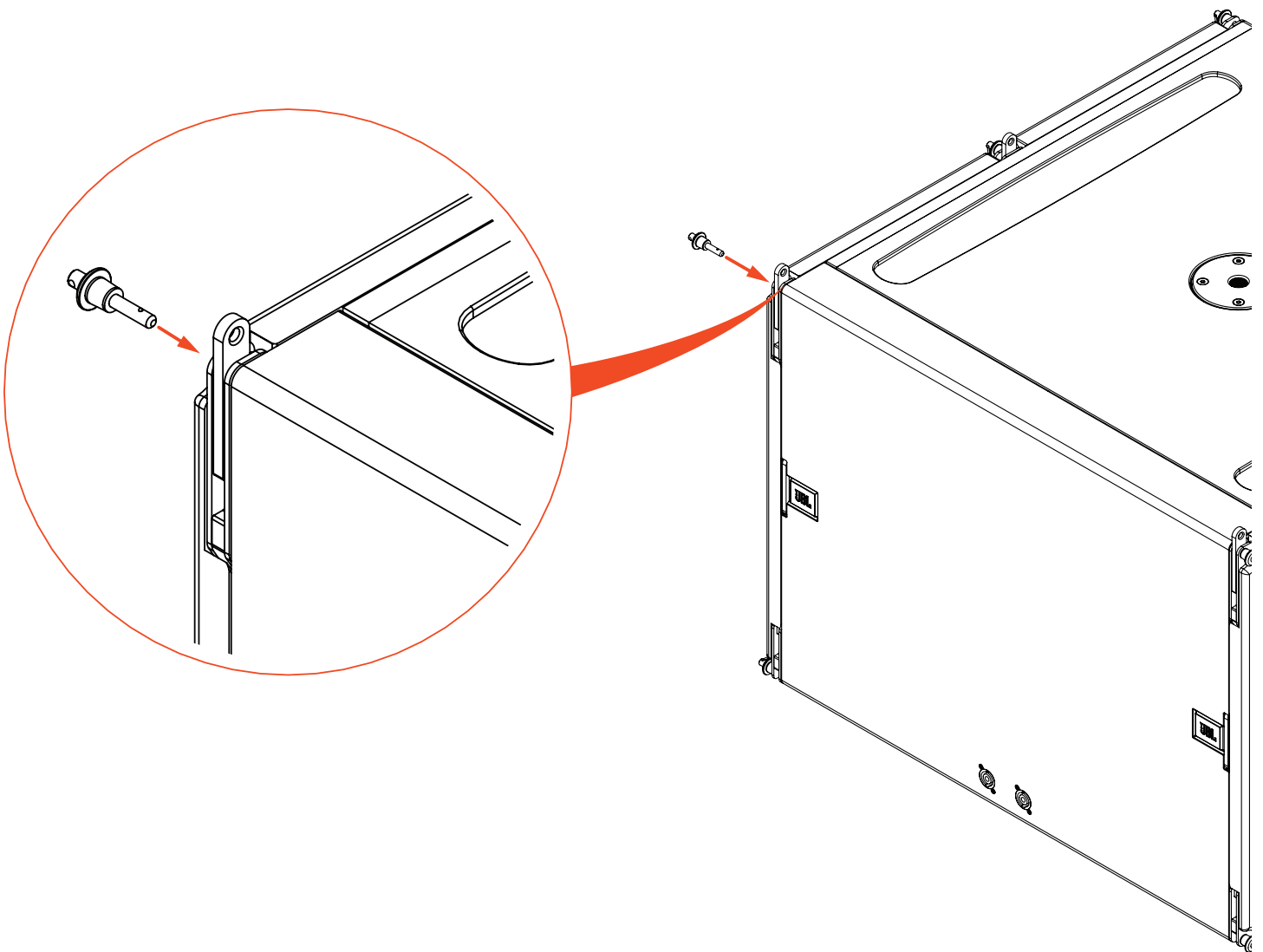

CAUTION: No quick release pins should be left unused when deploying B18 cabinets in suspended configurations.

When suspending multiple B18 cabinets together, all six rigging points (three per side) should be used for all B18 cabinets, with the exception of the top cabinet, which connects to the array frame. Two quick release pins should be used per attachment point as illustrated below. No quick release pins should be left unused.

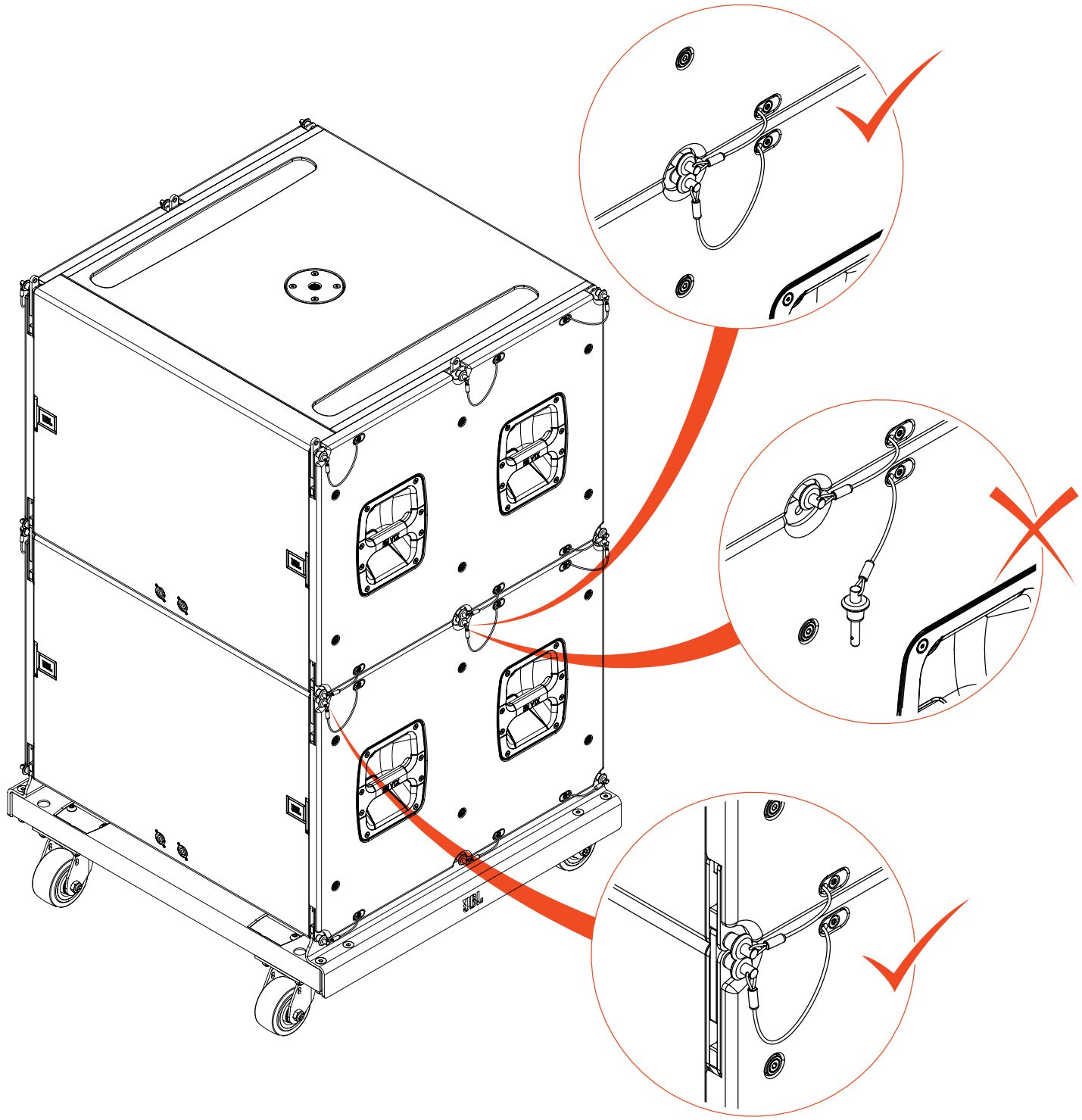

CAUTION: No quick release pins should be left unused when deploying B18 cabinets in suspended configurations.

8 - TRANSPORTATION OPTIONS

There are two transportation options for the B18. The first option is the vertical transportation cart (VTX B18 VT), which carries a stack of two, three, or four B18 cabinets, in either a front-firing or cardioid configuration. The VTX B18 VT CVR, a reinforced protective cover is available to cover and protect the subwoofers during transportation. The second option is the VTX B18 ACC accessory kit, which includes a front face dolly for a single B18 and a protective cover. The VT option is ideal for major touring situations, where large-format trucks are used and maximum deployment efficiency is needed. The ACC option is more agile and efficient for transportation, since B18 subwoofers can be stacked on top of other product in the trucks.

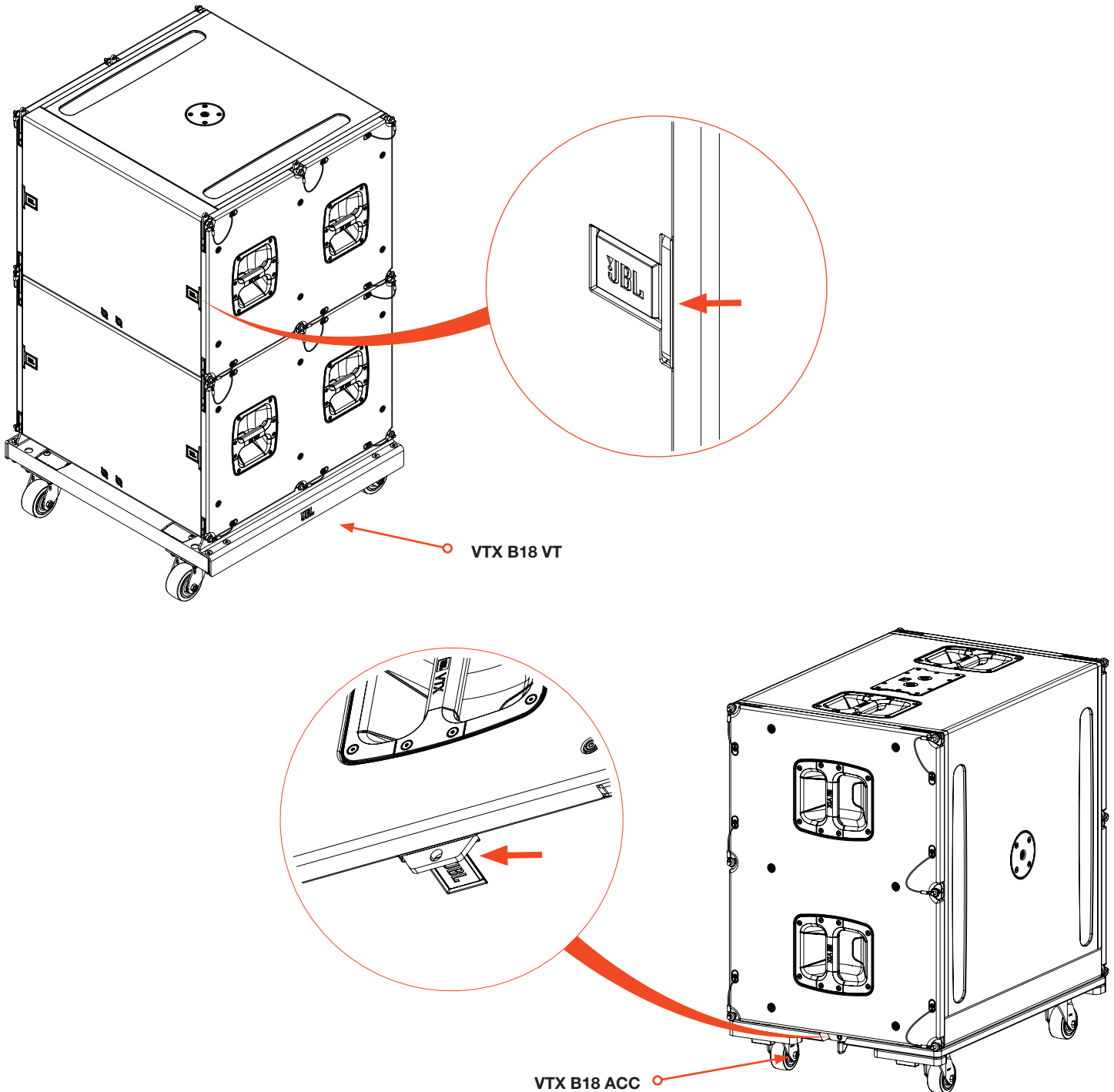

8.1 ROTATING THE DOLLY TABS FOR USE WITH THE ACC DOLLY

Two retractable dolly tabs at the front of the B18 are used to secure the ACC dolly board to the subwoofer. The tabs ship from the factory facing the inside of the B18, which is ideal for transporting B18s on a vertical transport cart, when the tabs are not needed. However, to attach a front face dolly board to a B18, the tabs must be rotated.

STEPS:

- 1 Remove the four M6 HEX screws holding the grill onto the B18
- 2 Carefully disconnect the Molex™ connector that connects the two front NL4 connectors to the B18

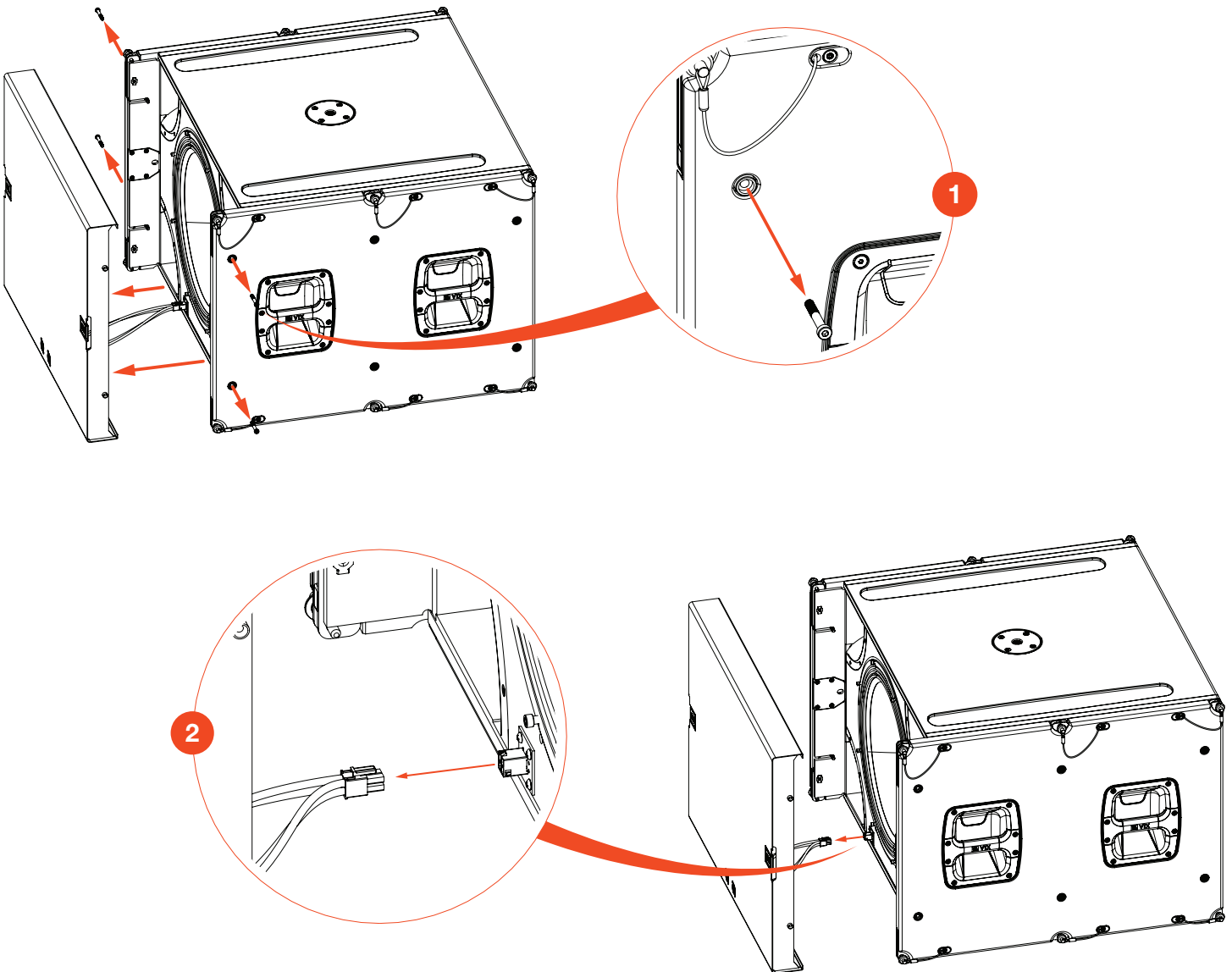

TOOLS REQUIRED: A 4 mm HEX key is required to remove the four M6 screws holding the grill onto the B18. A Phillips #2 screwdriver is required to remove the four Phillips screws holding the dolly tab.

STEPS:

- 3 Remove the four Phillips screws holding each tab, reverse its orientation, and reinstall the Phillips screws
- 4 Reconnect the Molex connector and secure the grill

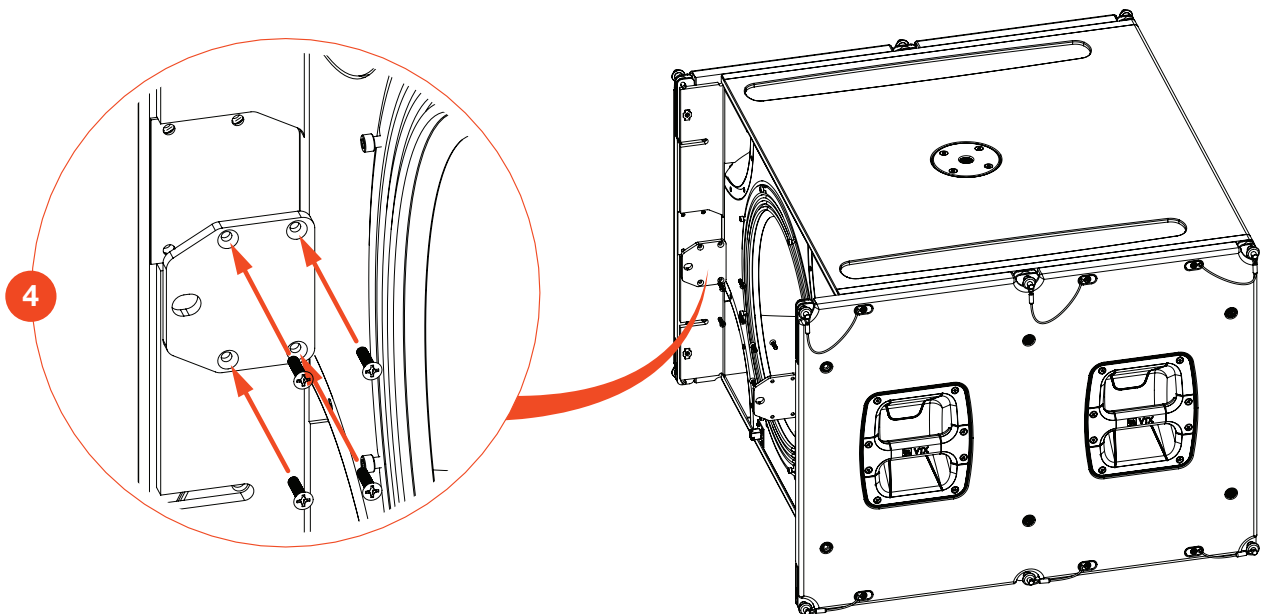
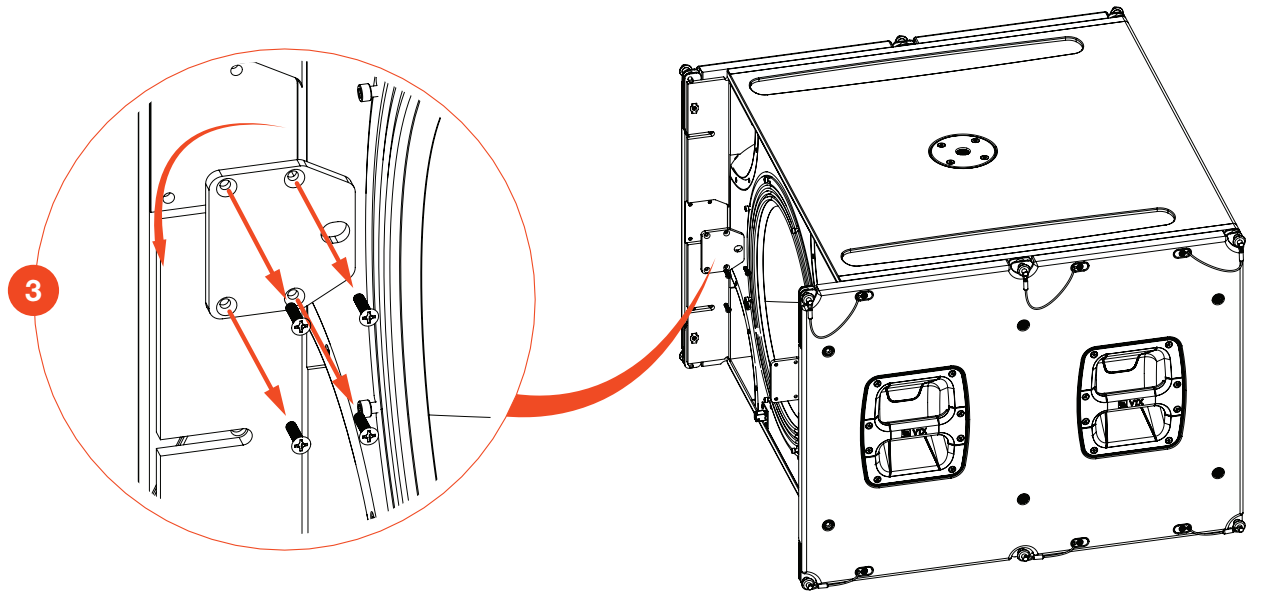

TOOLS REQUIRED: A 4 mm HEX key is required to remove the four M6 screws holding the grill onto the B18. A Phillips #2 screwdriver is required to remove the four Phillips screws holding the dolly tab.

8.2 VTX B18 ACC DOLLY OVERVIEW

The VTX B18 ACC dolly board features two beveled, recessed, rotating cams (one on each side), which are used to attach the dolly board to a B18 cabinet. The dolly board seats on the B18 mounting tabs and is secured by the rotating cams.

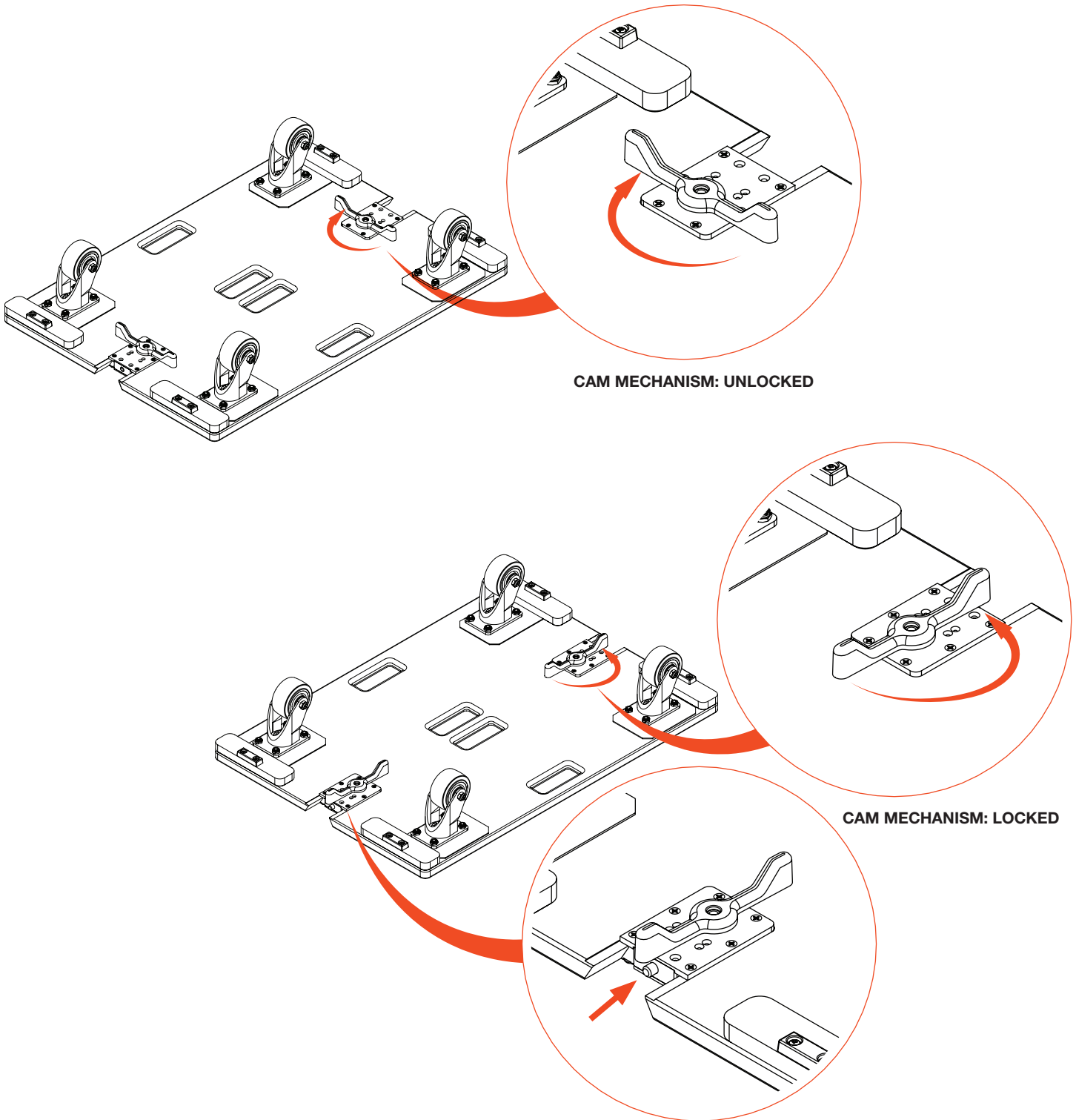

TIP: The rotating cam mechanism can be released using your feet while B18 cabinets are faced down.

8.3 ATTACHING THE VTX B18 ACC DOLLY

STEPS:

- 1** Flip one of the two cam mechanisms to the locked position
- 2** Slide the ACC dolly-board on to the B18 from one of the two sides
- 3** Lock the other cam mechanism to secure the ACC onto the B18

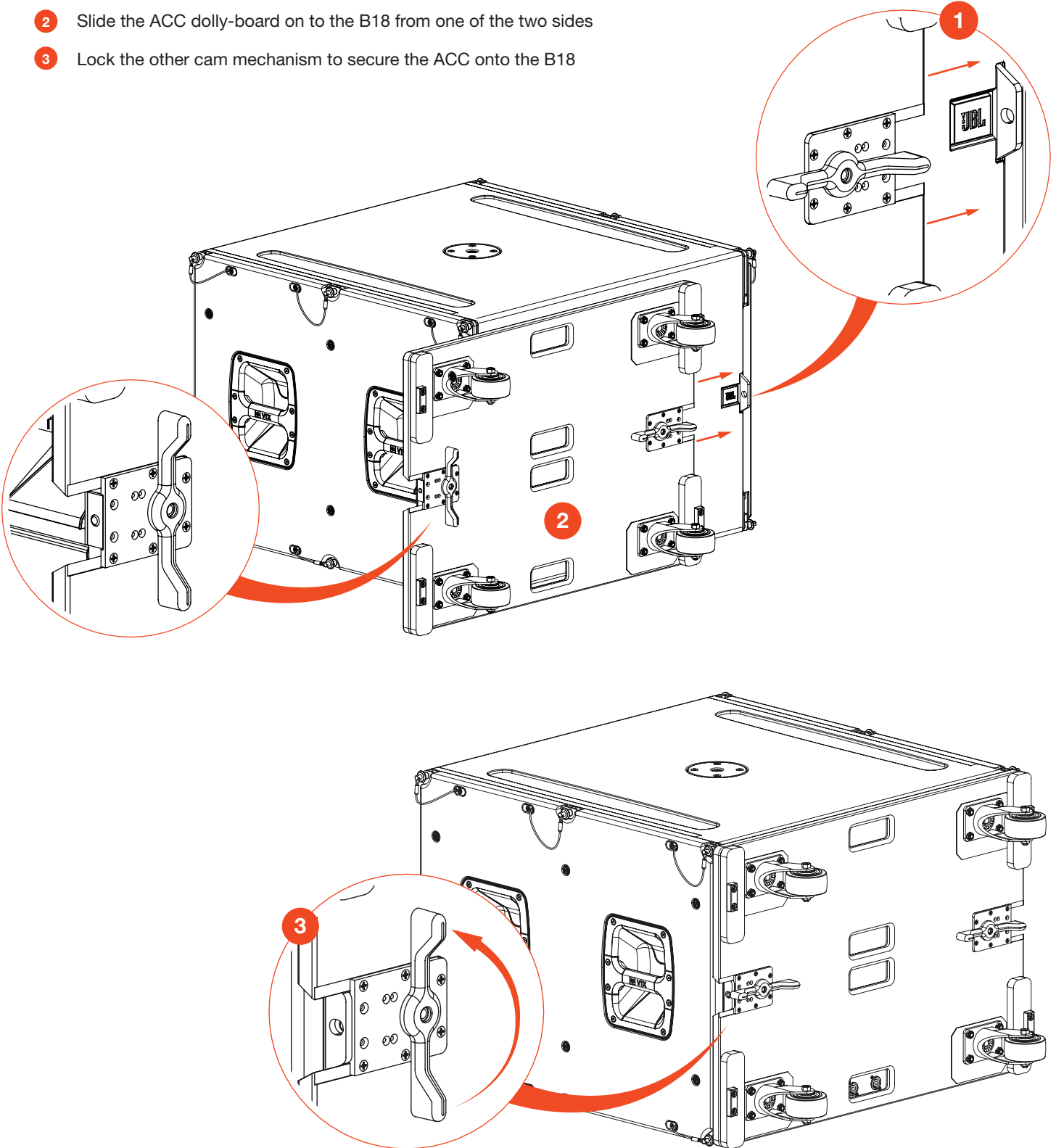

8.4 STACKING THE ACC DOLLY BOARDS

VTX B18 ACC dollies can be stacked together for storage. The top of an ACC dolly board features wheel wells of two different sizes. Dolly boards should be stacked so their orientations alternate. A stacked dolly's long wheel wells should sit directly above the short wells of the dolly below it. This technique builds stable and compact stacks of ACC dollies without having to touch or manually turn the wheels.

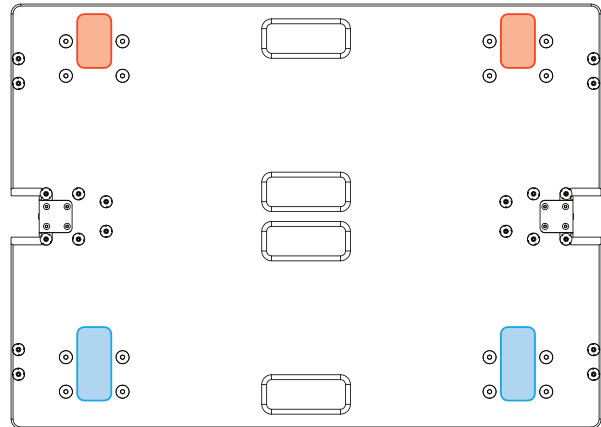

STEPS:

- 1 Place the first ACC dolly on the ground.
- 2 Lift the next ACC by the handle between the short wheel wells, so that it hangs vertically and the wheels orient themselves downwards.
- 3 Place the lower two wheels into the short wells of the ACC on the ground.
- 4 Once aligned, lower the other side. The other two wheels will seat into the long wells.
- 5 Repeat the process to stack all ACC dolly boards.

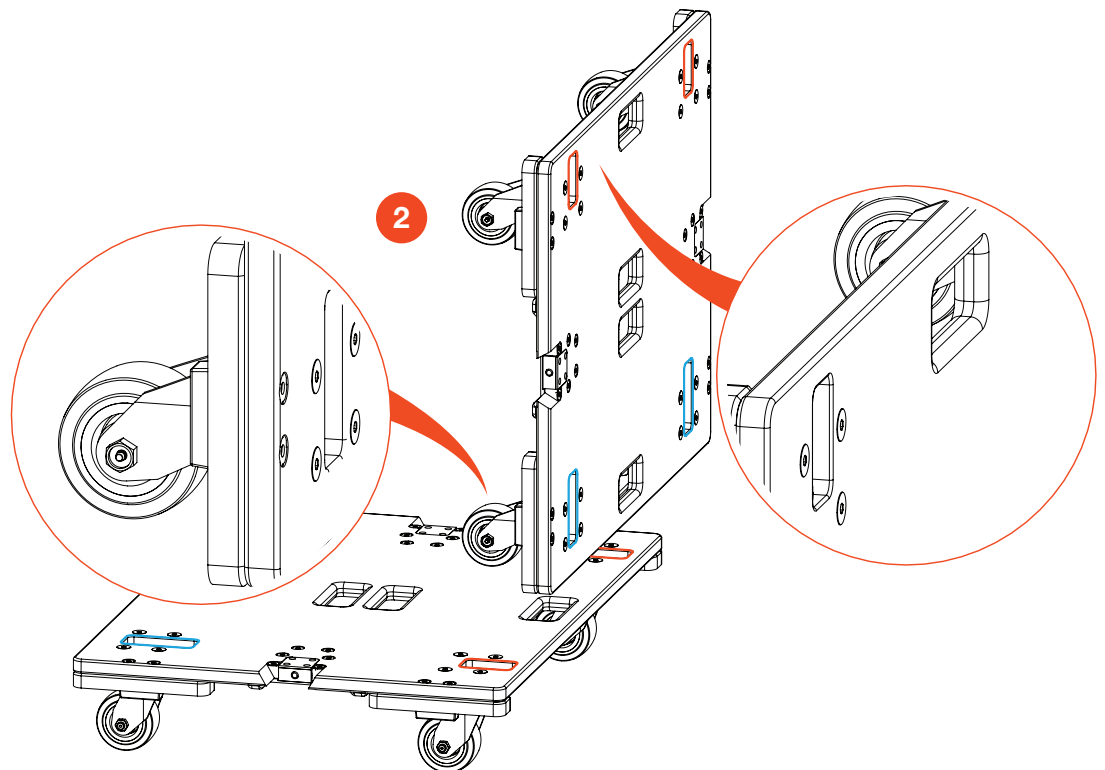
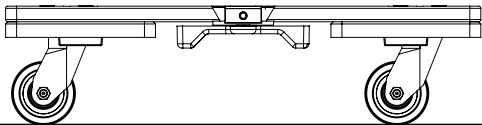

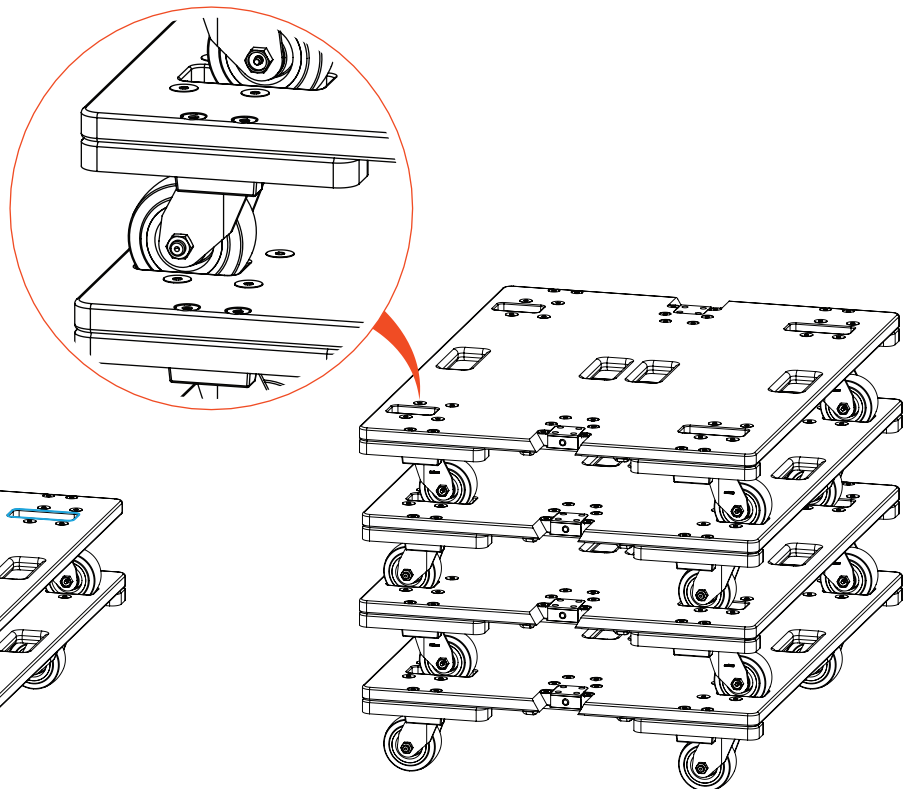
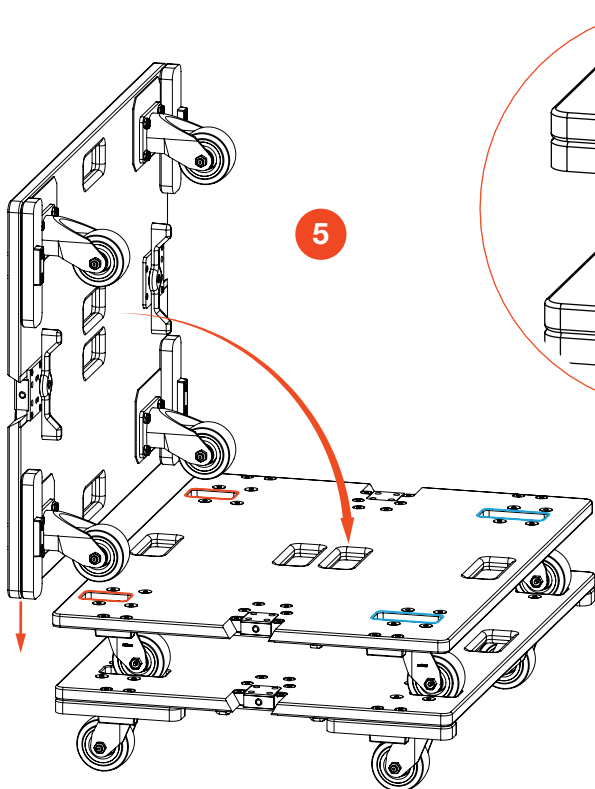
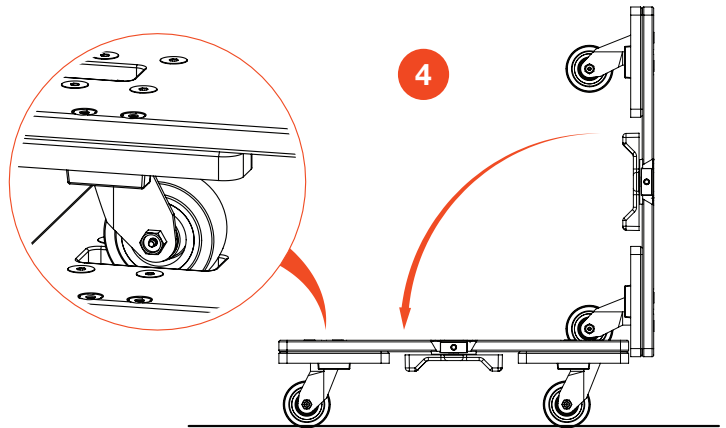
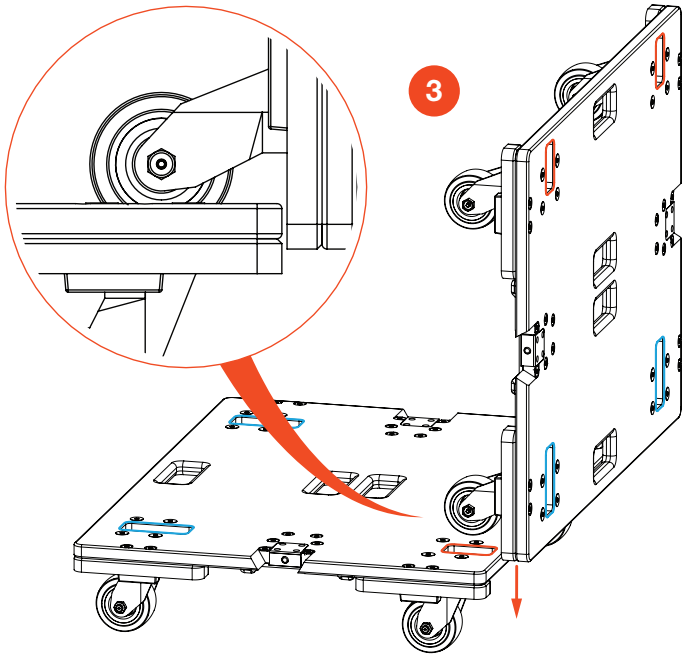

8.5 TRUCK PACKING WITH THE VTX B18 ACC

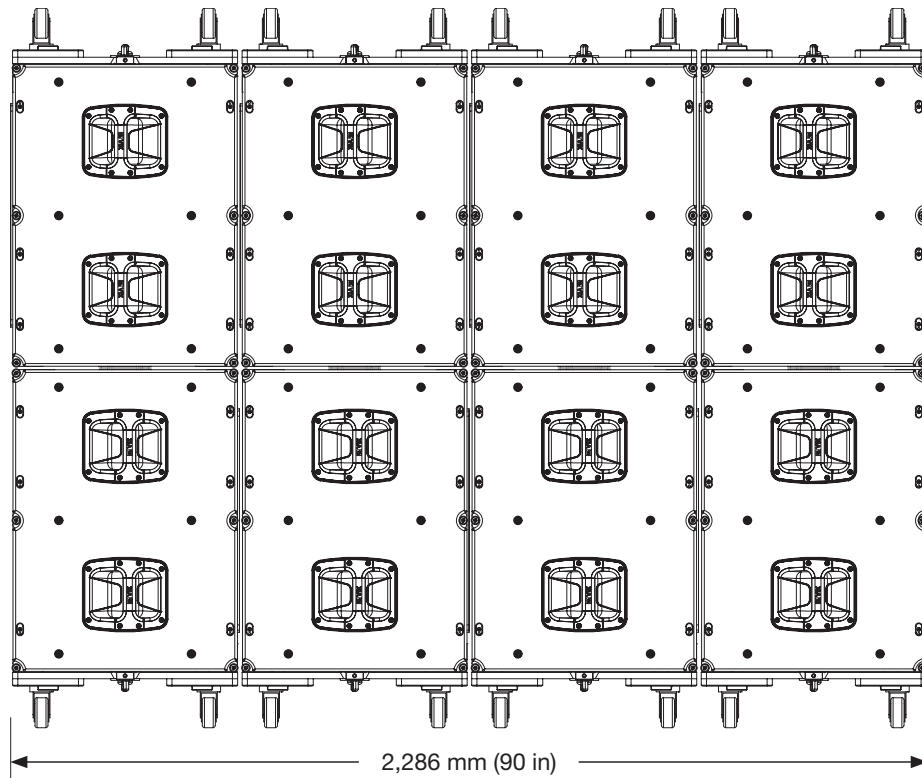
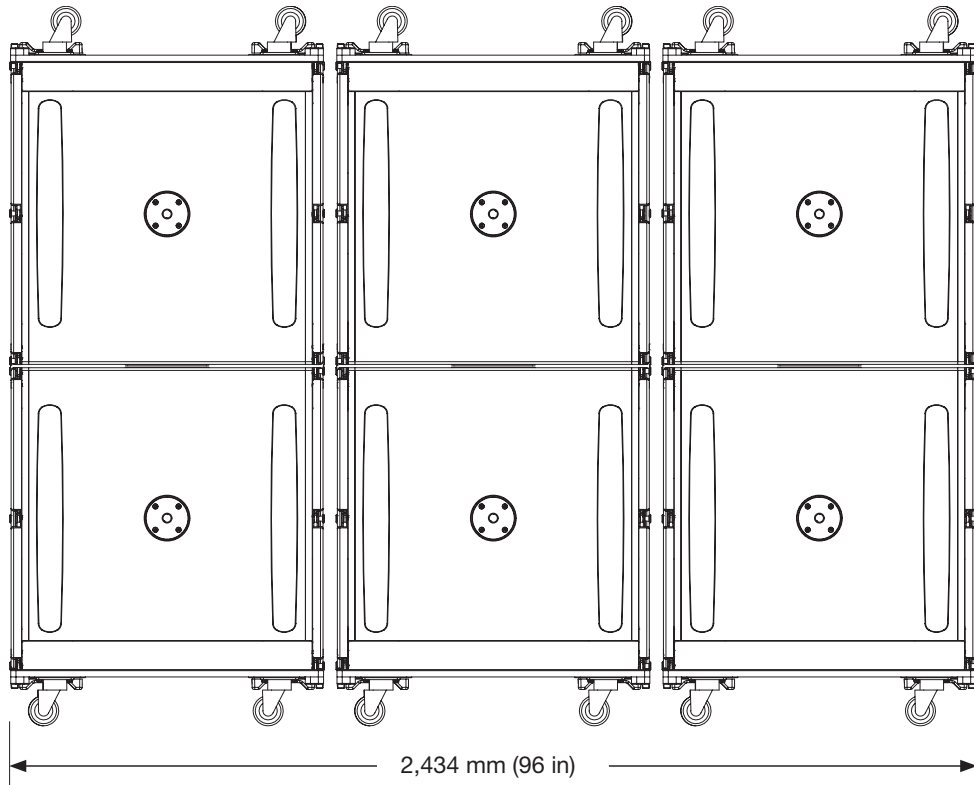

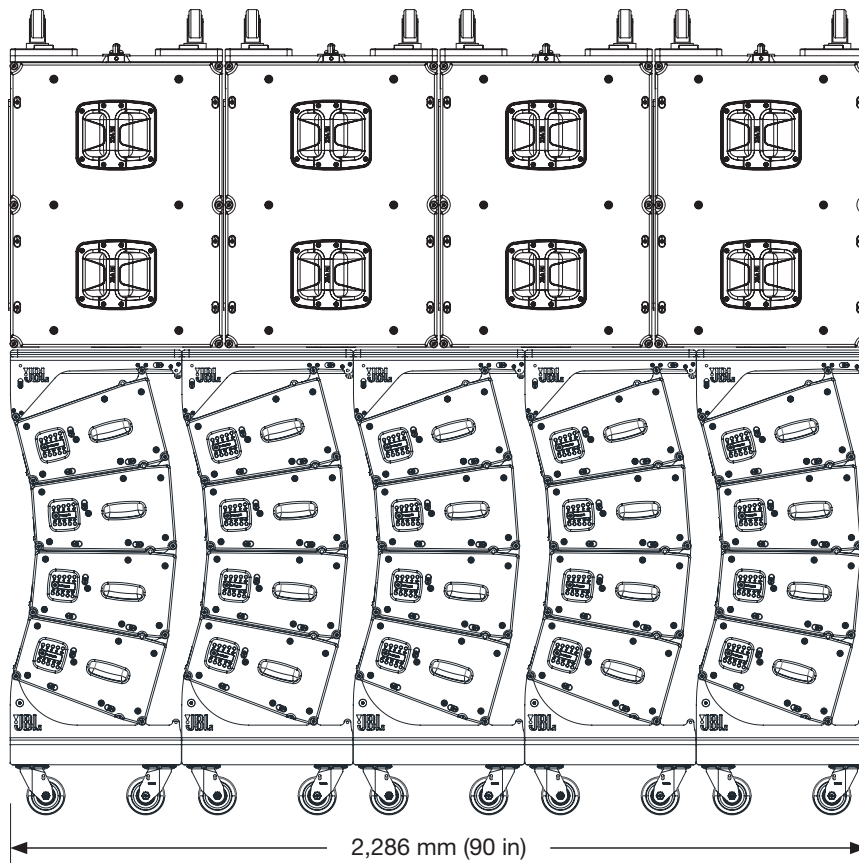
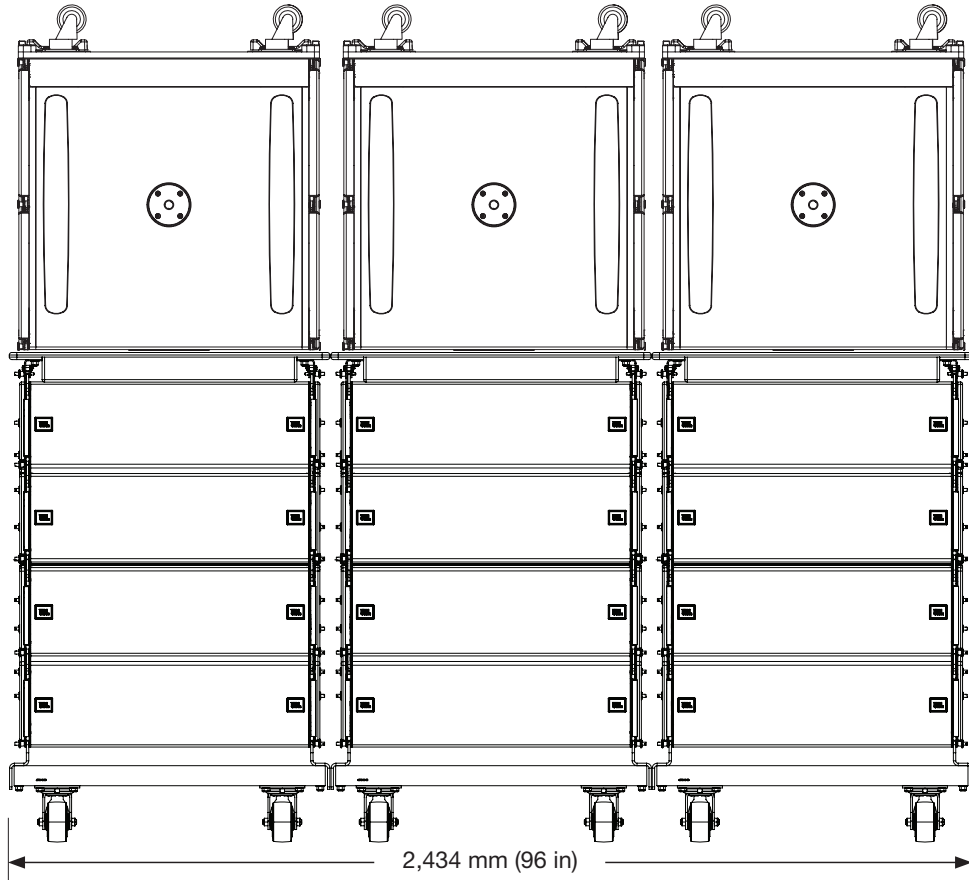

8.6 INSTALLING VTX B18 CABINETS ON A VT

To install B18 cabinets on to the VTX B18 VT transportation cart, follow the instructions below. Up to four B18 enclosures can be transported on a VT cart.

STEPS:

- 1 Remove the quick release pins at the four corners of the B18 cabinet to which the VT will be attached.
- 2 Carefully lower the B18 onto the VT cart and make sure all corners are aligned.
- 3 Replace the quick release pins to the corners.

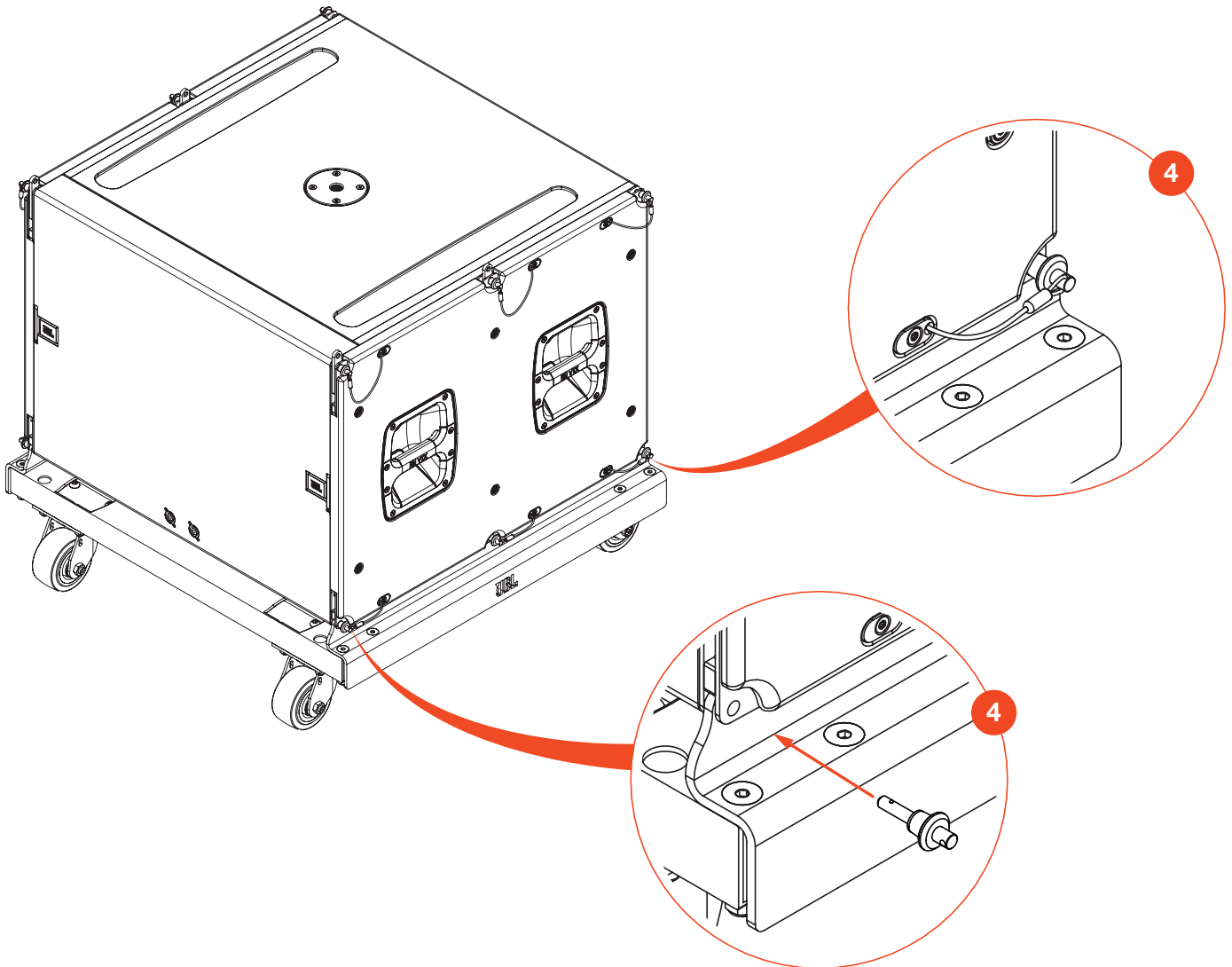

TIP: In this configuration, the two quick release pins at the center are not used. The VT cart attaches to the B18 using only the corner attachment points.

To stack multiple B18s on a transportation cart, the rigging bars of the lower subwoofer must be deployed.

STEPS:

- 1 Deploy the six rigging bars of the lower B18 by temporarily removing the quick release pins.
- 2 Once the rigging bars have been deployed, replace the pins to the same positions.
- 3 Remove the lower six quick release pins from the next B18 above.
- 4 Carefully lower the upper B18 onto the lower B18

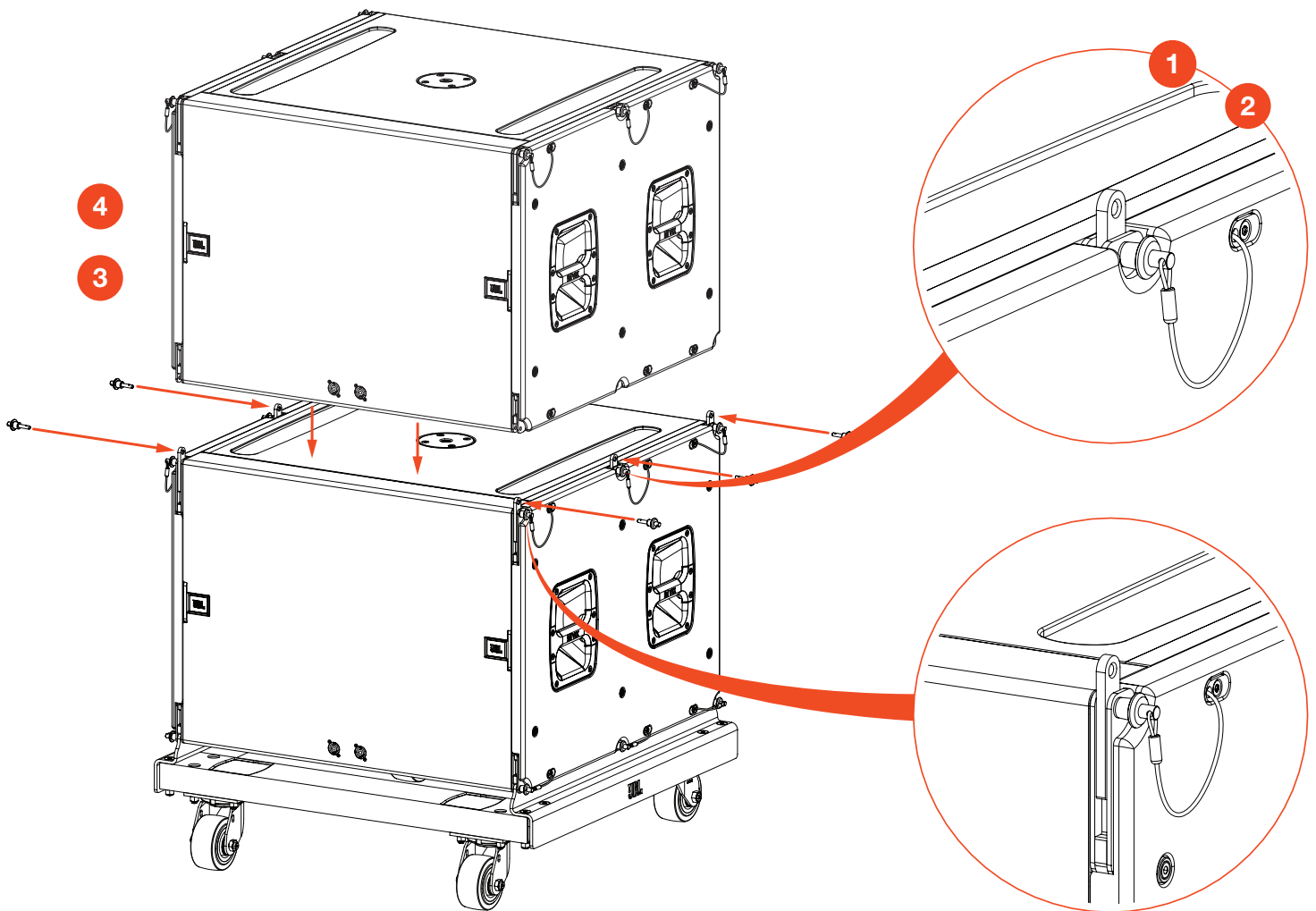

STEPS:

- 5 Reinstall the six quick release pins

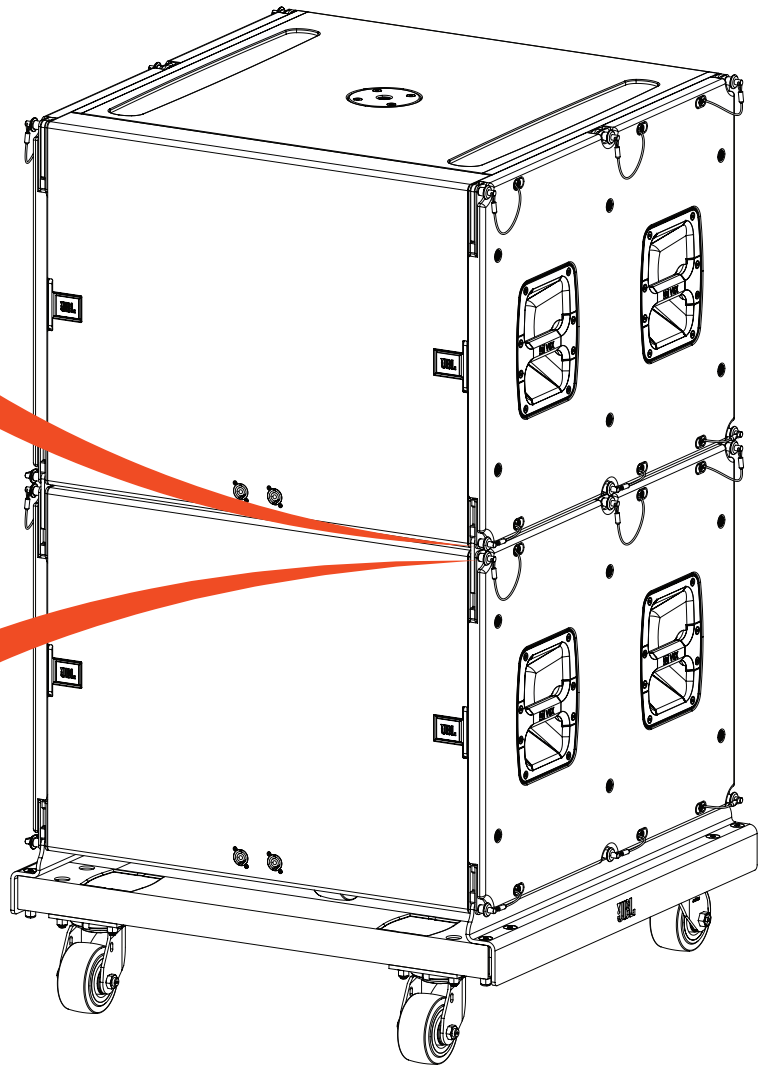
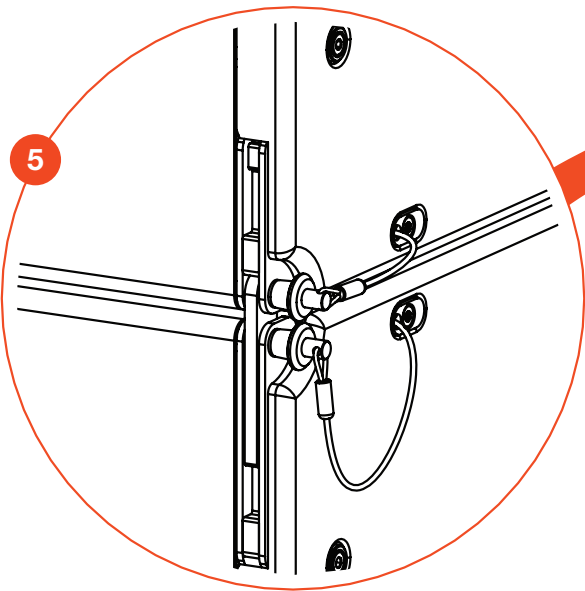
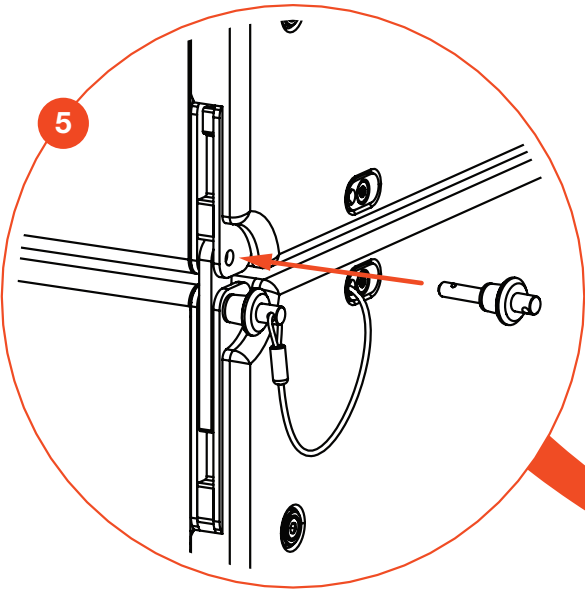

8.7 STACKING THE VTX B18 VT

The VTX B18 VT carts can be stacked together for storage.

STEPS:

- 1 Rotate the VT wheels so they point to the inside of the VT.
- 2 Line up the wheels.
- 3 Stack the two parts together.
- 4 Repeat until all VTs are stacked together.

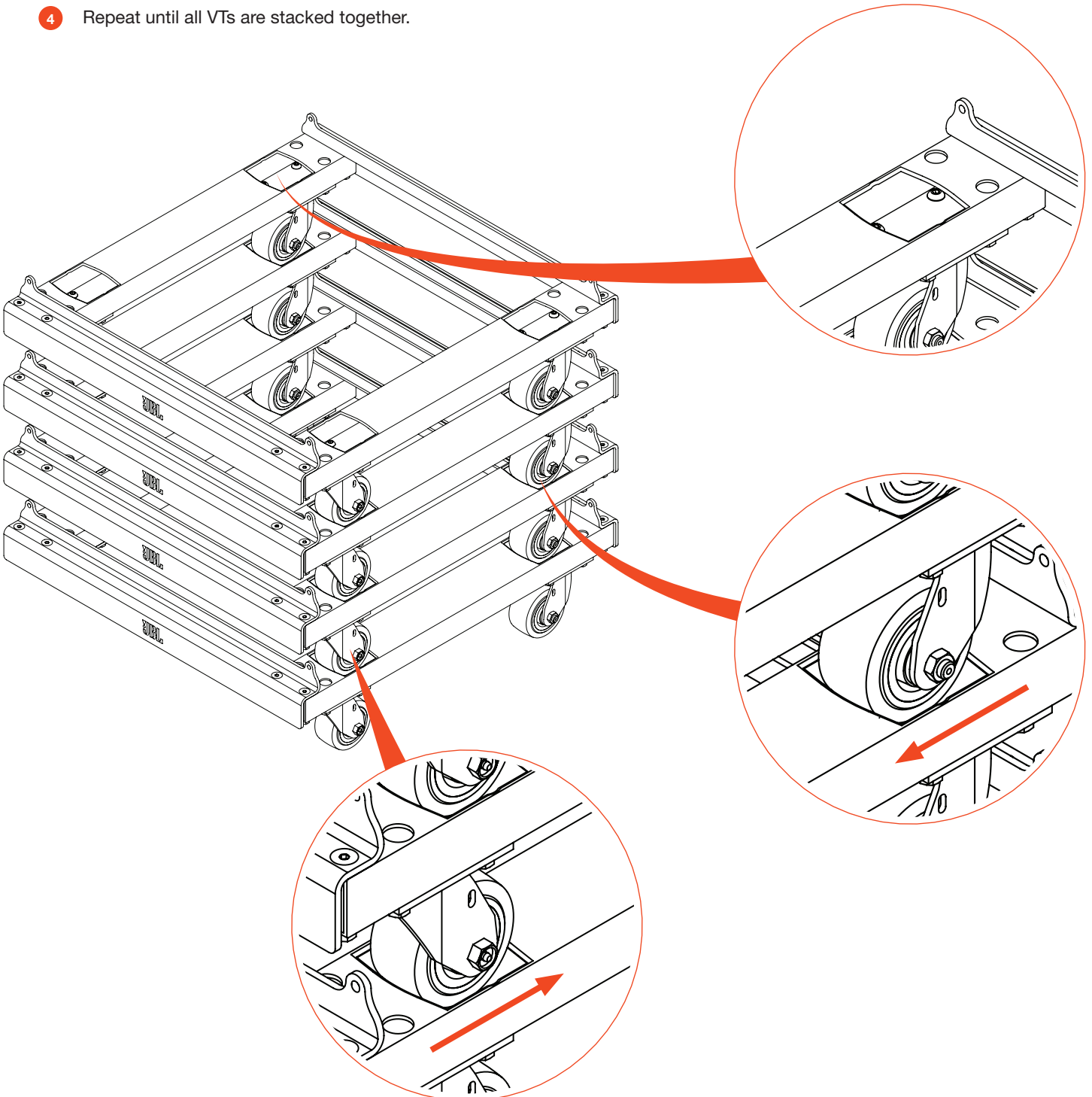

8.8 TRUCK PACKING WITH THE VTX B18 VT

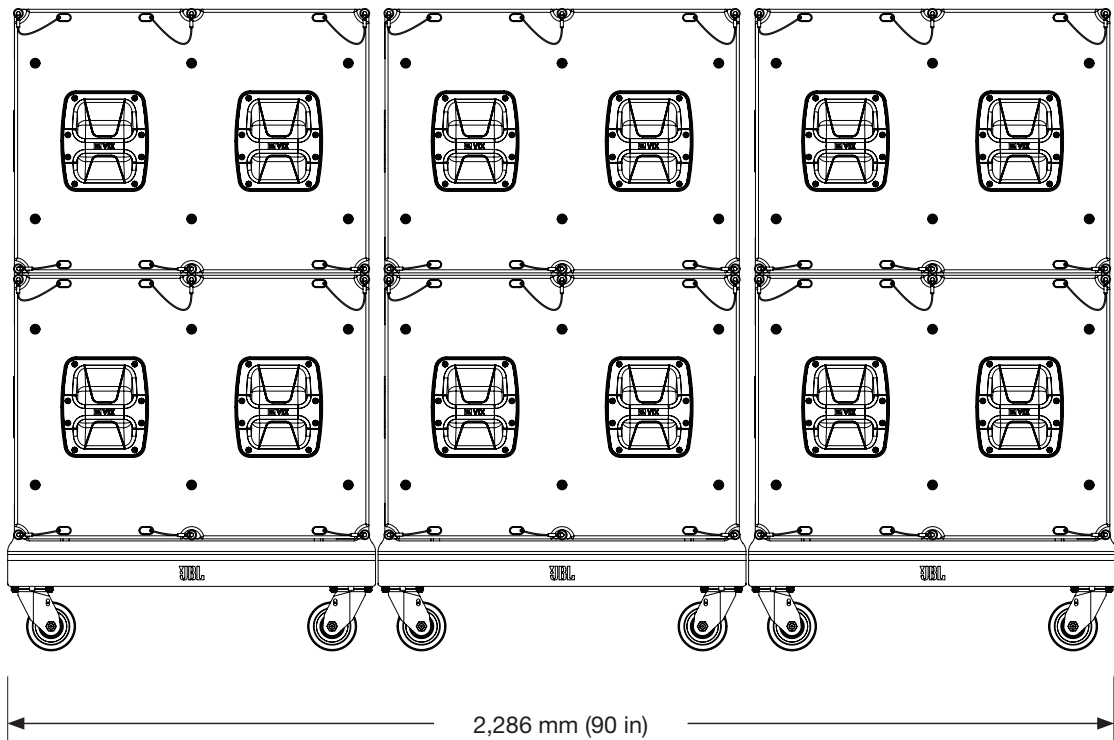
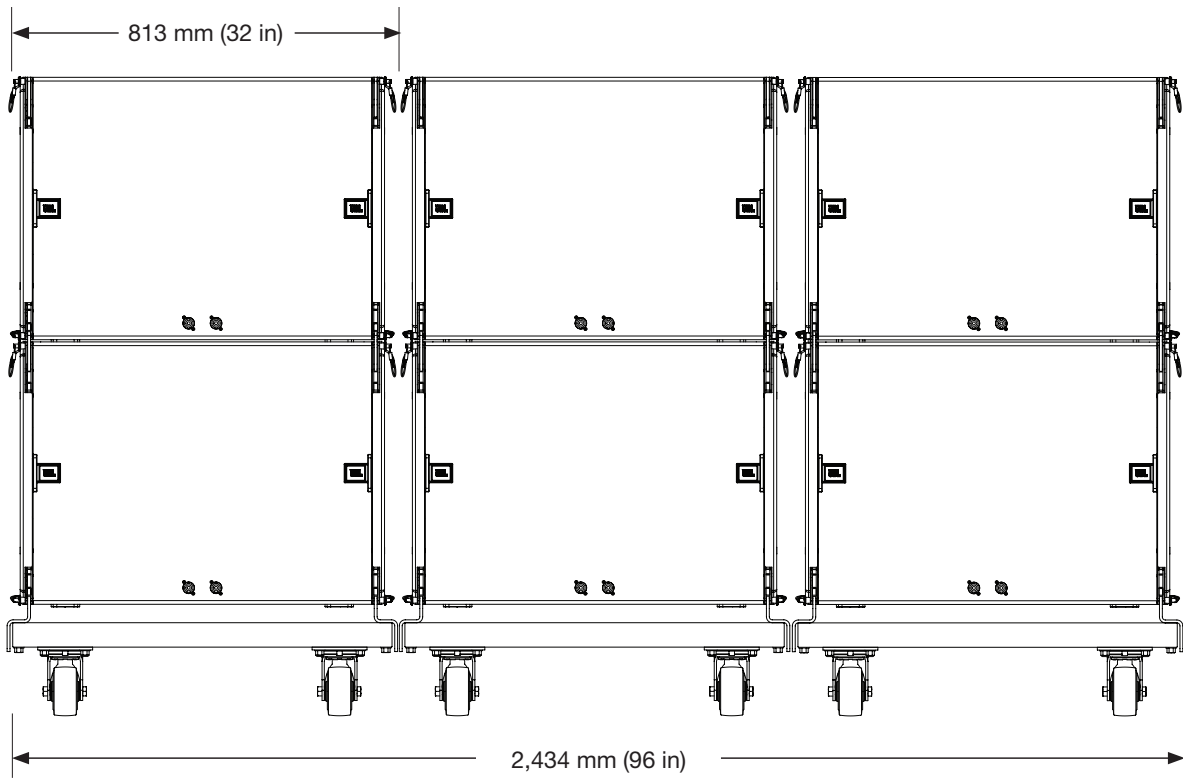

9 - SUSPENDING THE VTX B18

The VTX A8 AF is a lightweight Array Frame used for suspending VTX A8 and B18 cabinets. The frame was designed to operate in single-point, front-to-back, or side-by-side suspension mode using the VTX A8 AF EB Extension Bar. One Extension Bar is included with the frame and a second Extension Bar can be added to facilitate side-by-side suspension.



CAUTION: This manual describes the VTX A8 AF only in the context of the B18. For detailed information on the A8 Array Frame and full use cases refer to the VTX A8 Rigging Manual before using.

9.1 ATTACHING THE ARRAY FRAME

STEPS:

- 1 Extend the four front B18 rigging bars by removing the four quick release pins.
- 2 The rigging bars will automatically extend upwards. Once they have, restore the four QRPs to their original positions.

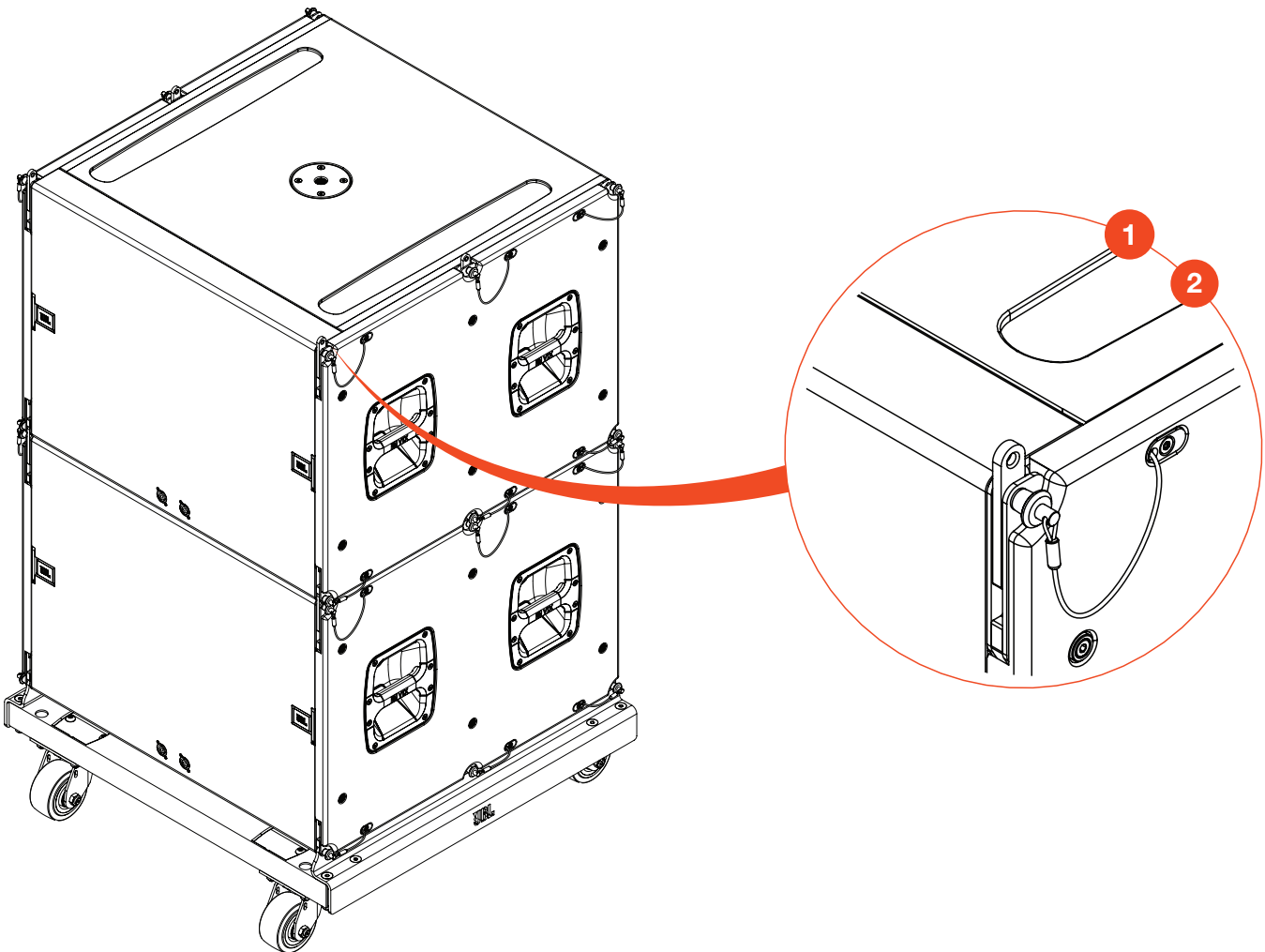

STEPS:

- 3** Attach the VTX A8 Array Frame to the four front B18 rigging points.
- 4** Attach the Extension Bar.

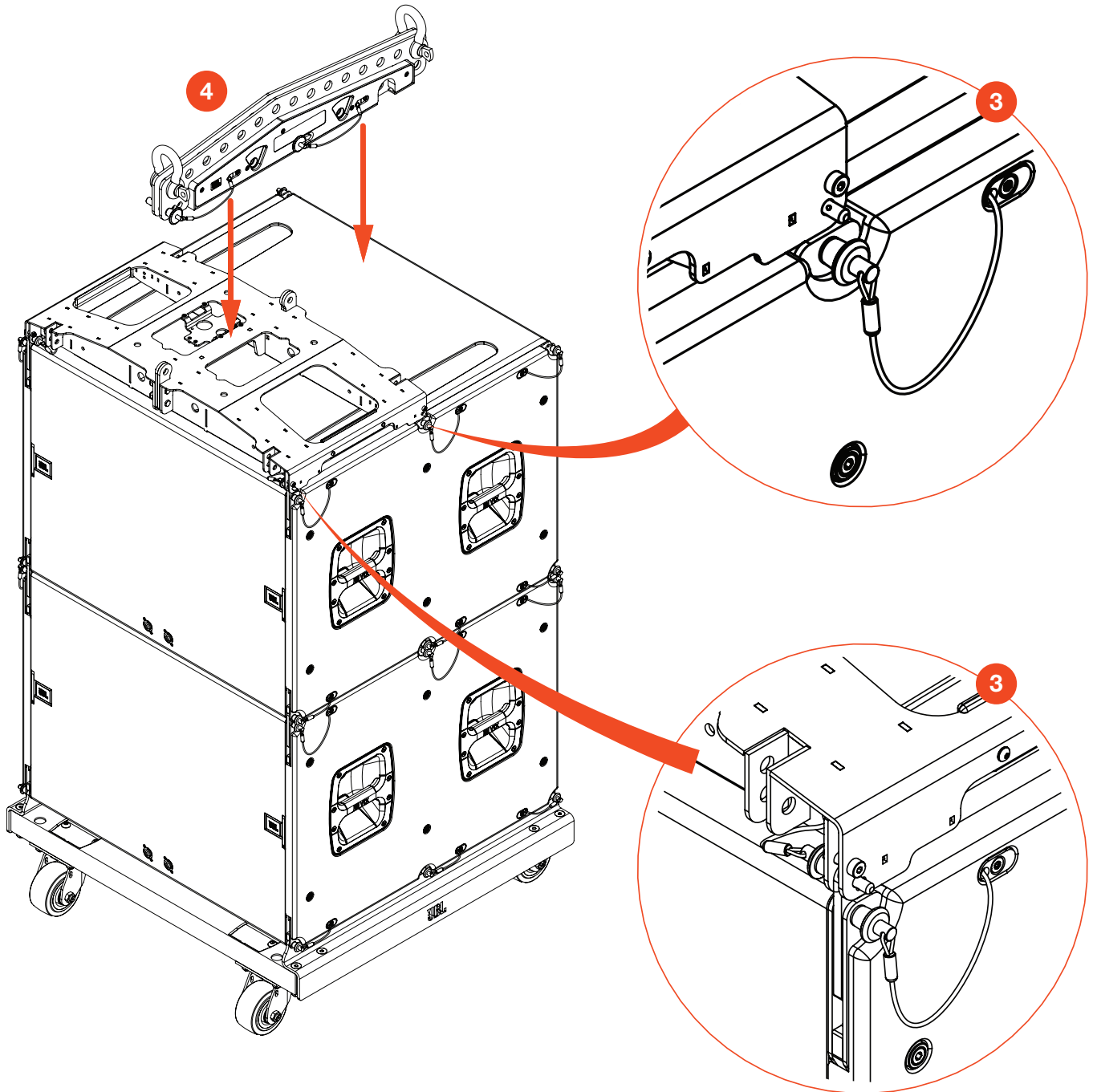



TIP: The VTX A8 Array Frame allows B18 subwoofers to be suspended using either a single suspension point or dual points. When using single-point suspension, the Array Frame position 8-B is in line with the B18 Center of Gravity and can be used to suspend a straight (no tilt) array.

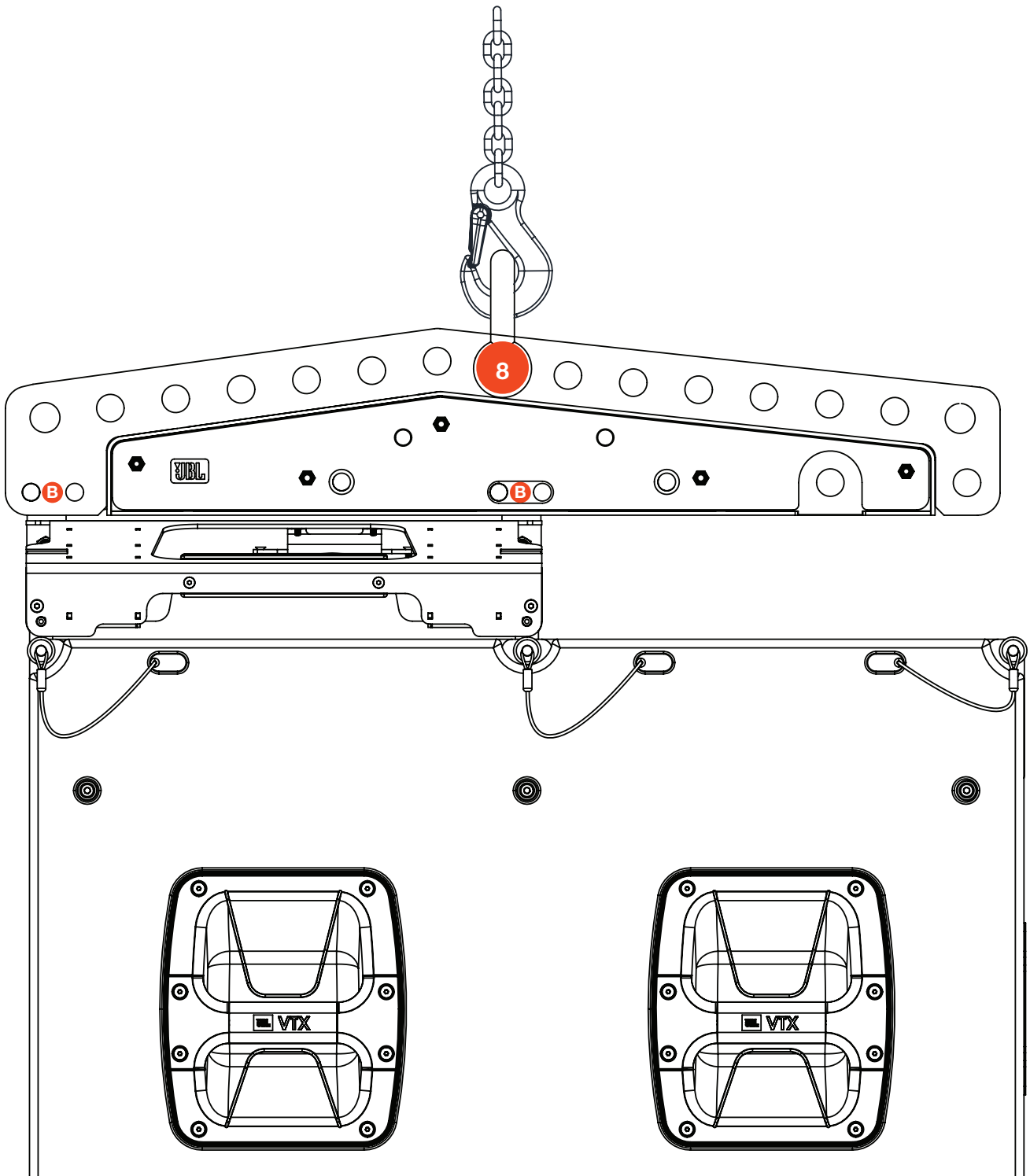

9.2 SUSPENDING B18 ARRAYS

STEPS:

- 1 When ready, remove the four lower B18 QRPs to release the B18 from the transportation cart.
- 2 Make sure all 12 (six per side) QRPs connecting the B18s together are in place.
- 3 Use an electric hoist to suspend the B18 stack.

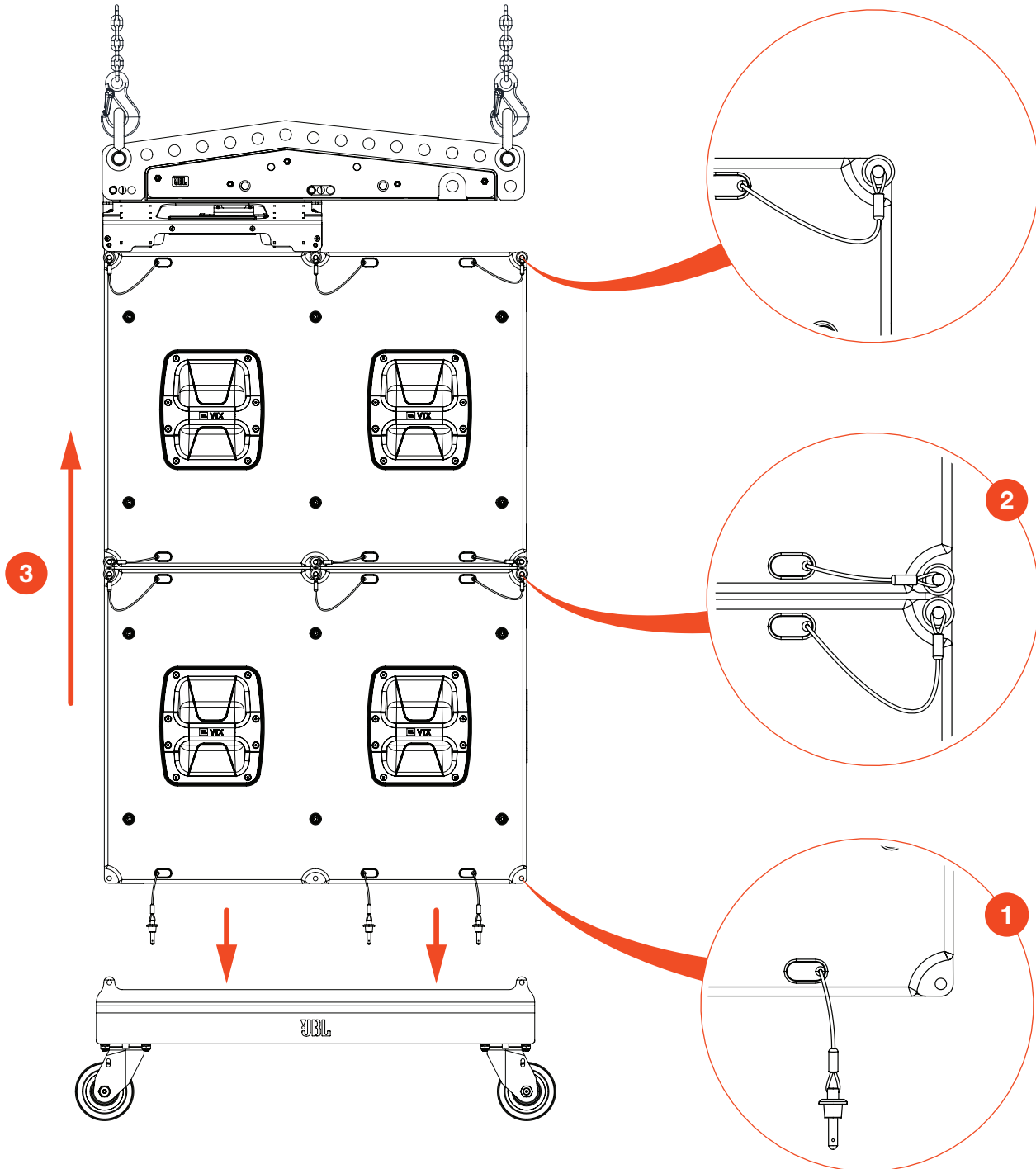

9.3 CONNECTING ADDITIONAL B18 STACKS

STEPS:

- 1 Extend all six rigging bars of the B18 stack on the ground and pin them in place.
- 2 Lower the flown stack until it rests on the ground-stacked B18s.

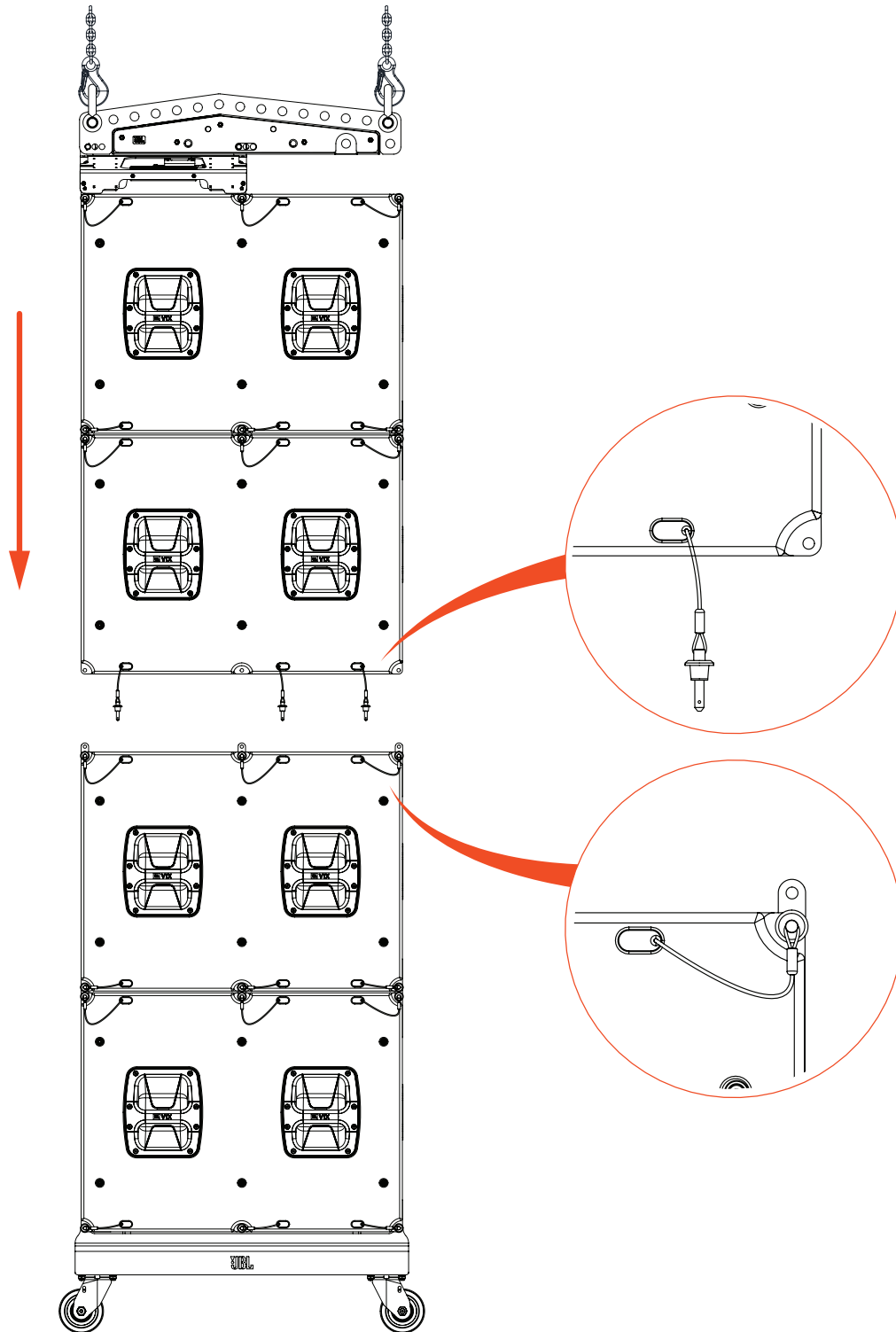

STEPS:

- 3** Use the six quick release pins of the upper B18 to secure the stacks together.

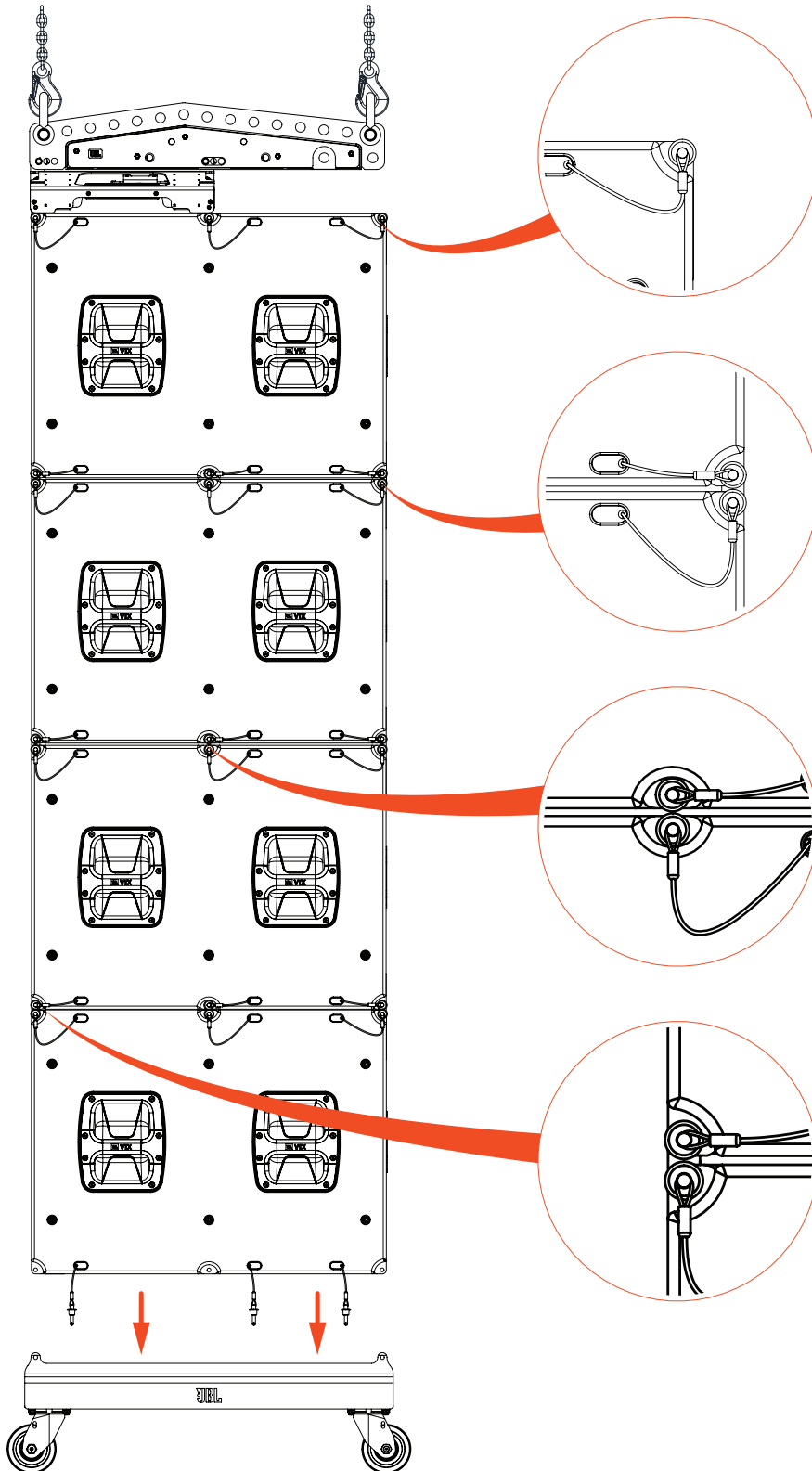

10 - THE VTX A8 SUSPENSION BAR

The VTX A8 SB is a lightweight suspension bar for suspending B18 arrays when the additional functionality of the Array Frame is not needed. A single suspension bar or dual bars can be used, depending on the array configuration and requirements. For suspension bar mechanical limits refer to Chapter 3 – Mechanical Limits.

10.1 SUSPENSION BAR OVERVIEW

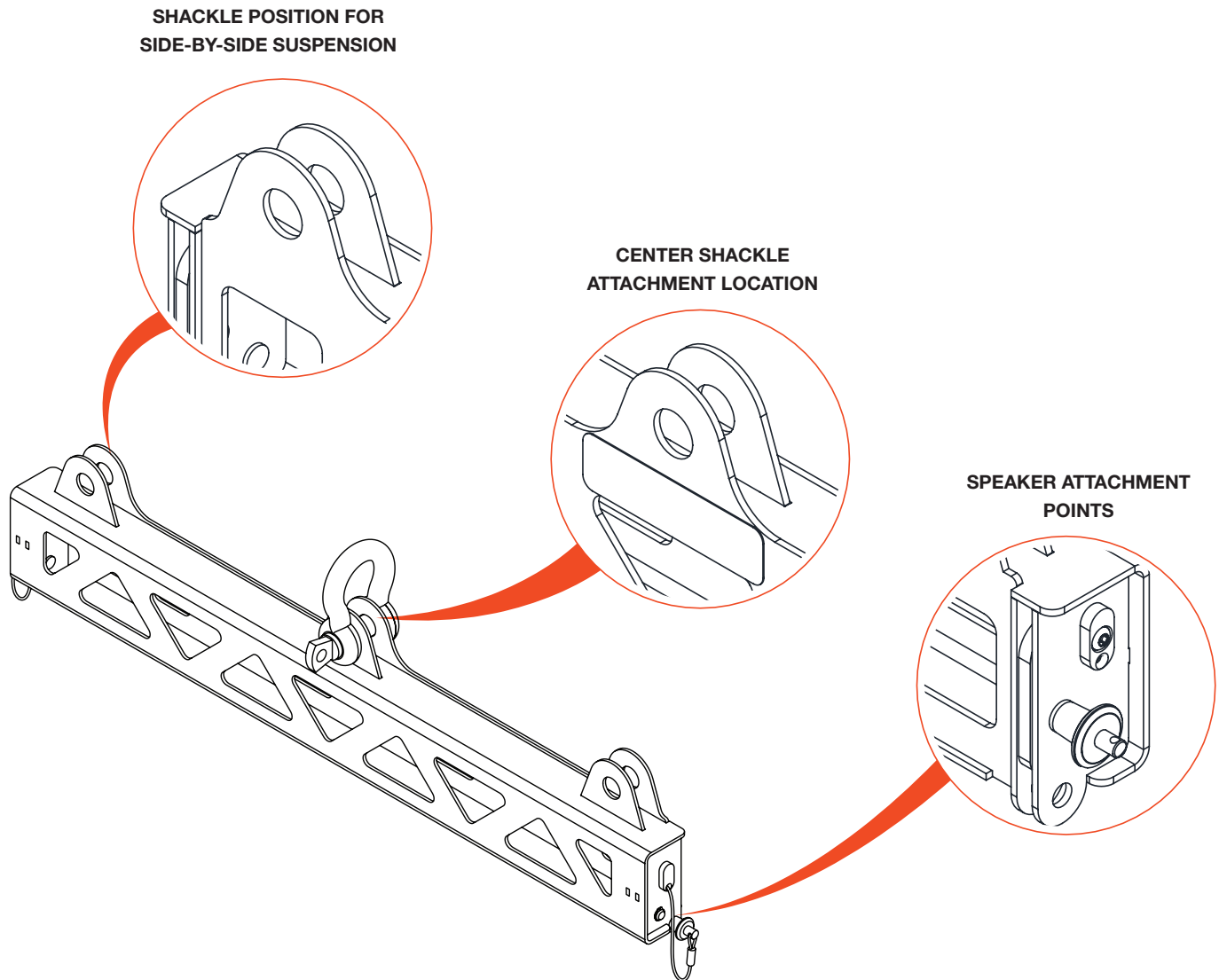

10.2 SUSPENSION BAR ATTACHMENT TABS

The Suspension Bar can be connected to either the bottom or the top of a suspended mixed array of VTX A8s and B18s. To attach a Suspension Bar to the VTX A8 or B18 cabinet at the bottom of an array, the array attachment tabs must be released from their storage positions. This is done by removing the quick release pins on either side of the SB and then letting the attachment tabs spring into place. The attachment tabs can then get pinned to the VTX A8 or B18 cabinet using the cabinet's QRPs.

EXAMPLES:

- A** Suspension Bar configured to attach to the top of an array.
- B** Suspension Bar configured to attach to the bottom of an array for pull-back.

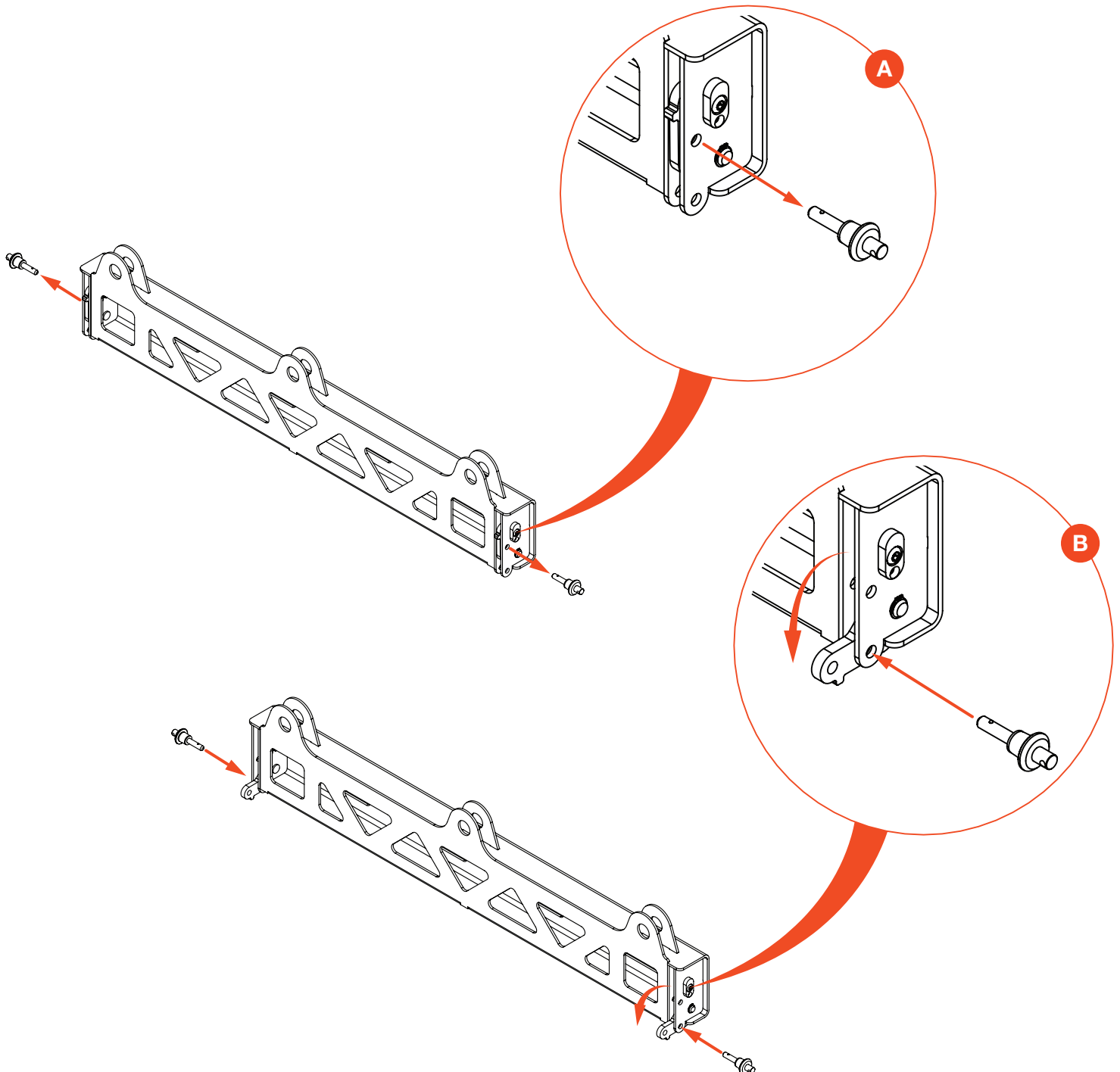

10.3 ATTACHING THE SUSPENSION BAR

STEPS:

- 1 Extend the B18 rigging bars that will be connected to the Suspension Bar.
- 2 Connect the Suspension Bar.

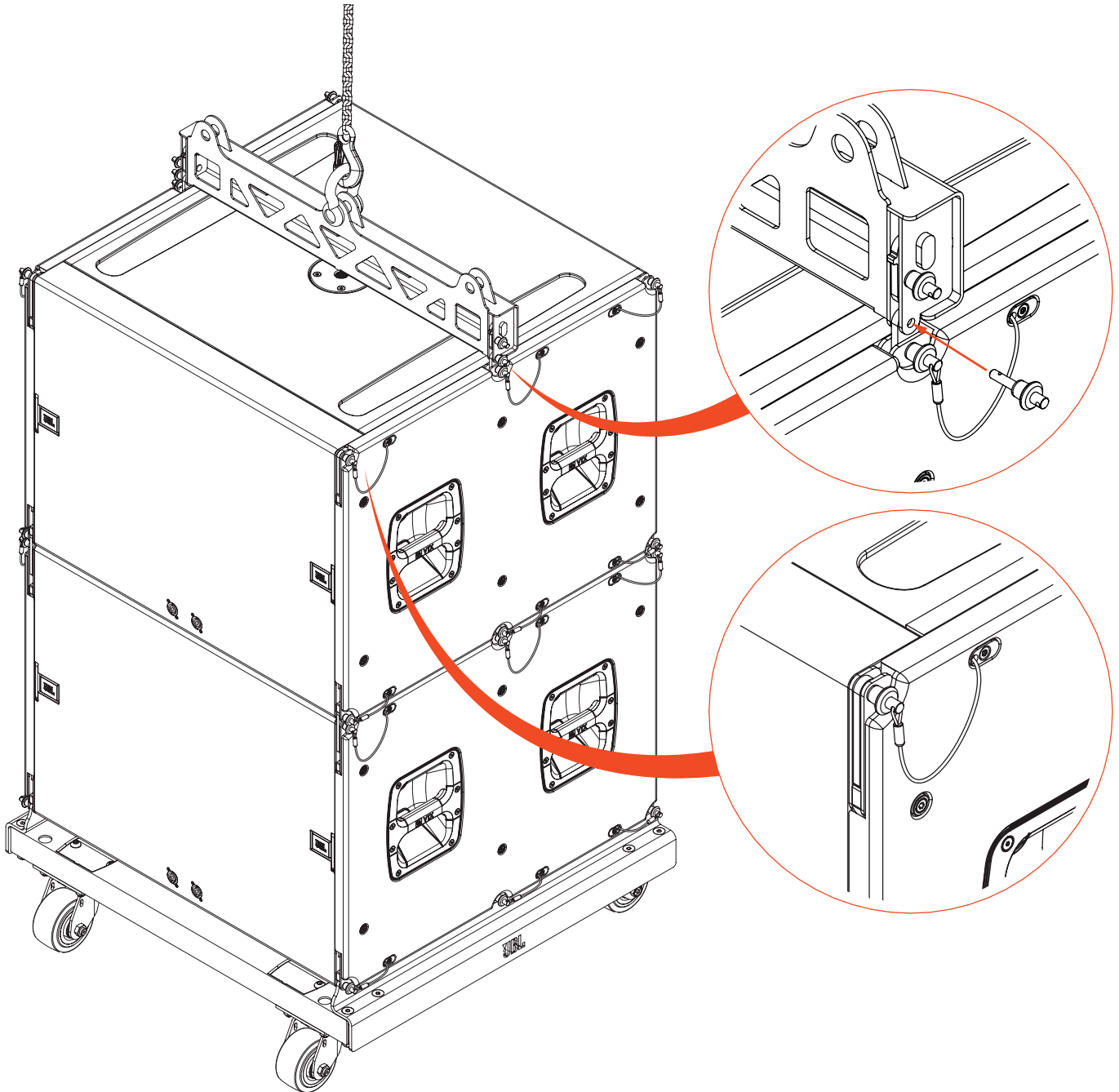

10.4 SUSPENSION BAR USE CASES

The VTX A8 Suspension Bar can be deployed in a number of configurations when used with B18 subwoofers. Below are some safe guidelines on use cases.

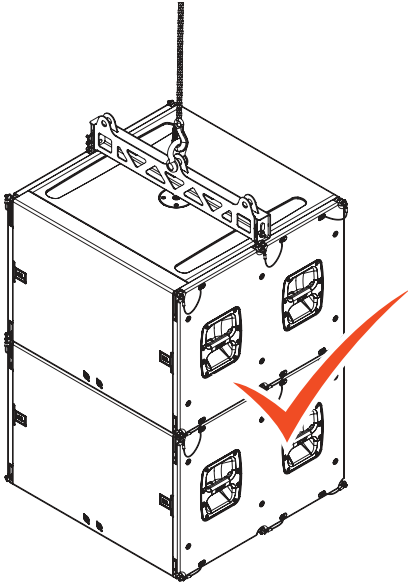

SINGLE SUSPENSION BAR
SINGLE-POINT

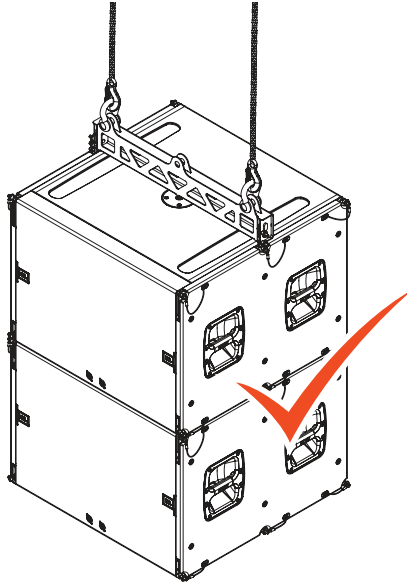

SINGLE SUSPENSION BAR
DUAL-POINT | SIDE-BY-SIDE

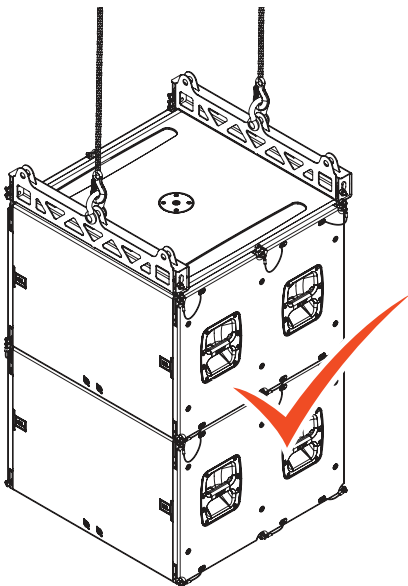

DUAL SUSPENSION BAR
DUAL-POINT | FRONT-TO-BACK

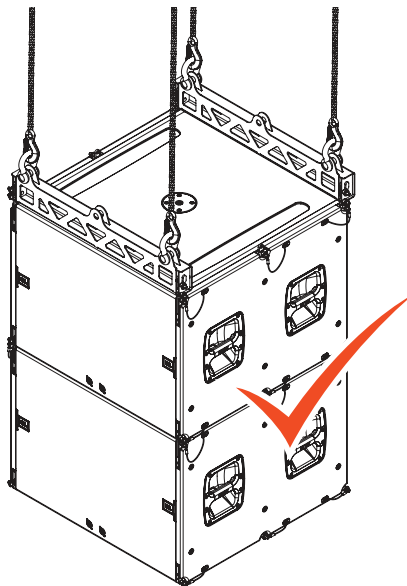

DUAL SUSPENSION BAR
QUAD-POINT | CORNERS

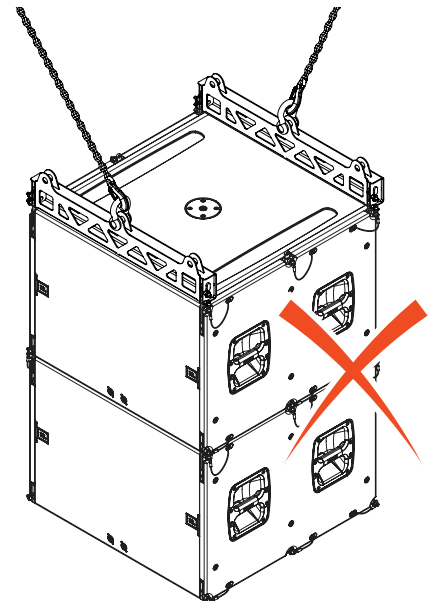

DUAL SUSPENSION BAR
DUAL-POINT | FRONT-TO-BACK

10.5 USING THE VTX A8 SB FOR PULL-BACK

The Suspension Bar can be used for pull-back at the bottom of a B18 array in array configurations requiring a significant amount of downtilt. Either the VTX A8 AF or an additional Suspension Bar can be used at the top of the array as the primary attachment point. A Suspension Bar at the top must be connected to the two center rigging points of the B18. This allows for easier and safer assembly, since the array remains straight during setup. When the AF array frame is at the top, the Extension Bar hole 8-B can be used, which also allows for a straight array during setup.

STEPS:

- 1 Assemble the B18 array based on the instructions from chapters 8 - Suspending The B18 Using The A8 Array Frame and the VTX A8 SB Suspension Bar.
- 2 Extend the Suspension Bar tabs as shown in section 9.2 Suspension Bar Attachment Tabs.
- 3 Attach the Suspension Bar to the bottom B18.

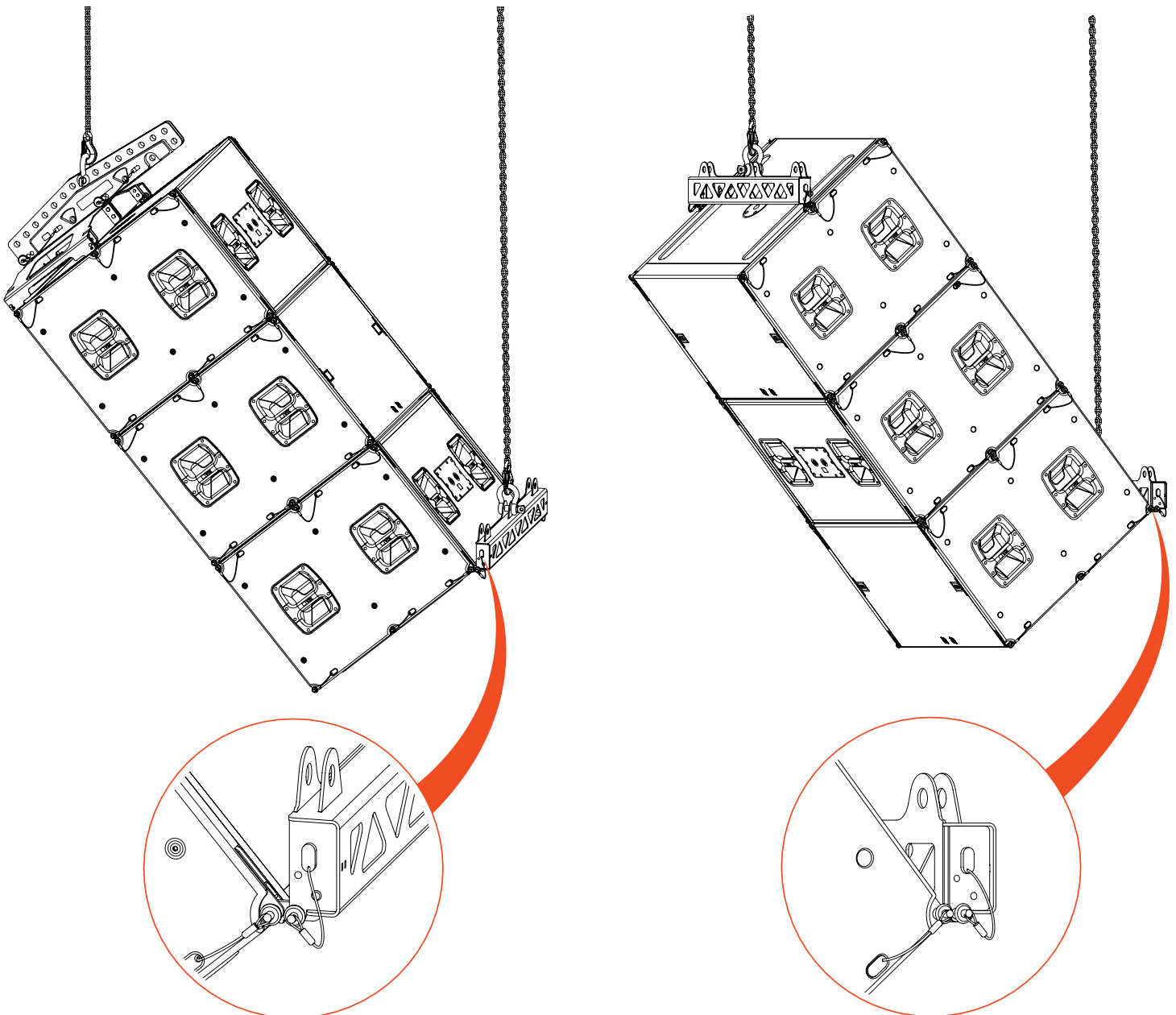

10.6 PULL-BACK USE CASES

Follow the examples below to safely implement pull-back for B18 arrays using the Array Frame and Suspension Bar.

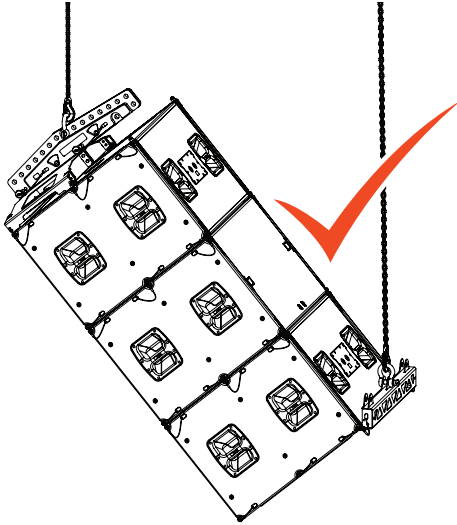

VTX A8 AF + VTX A8 SB
DUAL-POINT

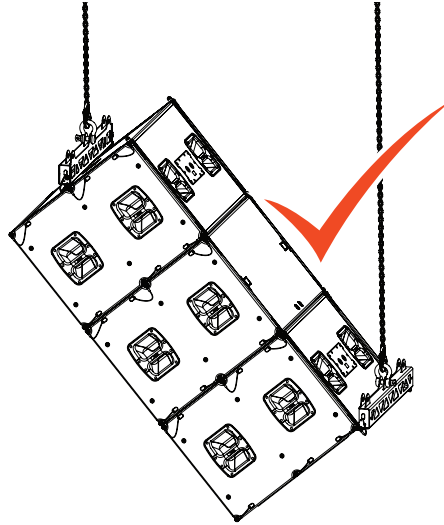

2X VTX A8 SB
DUAL-POINT

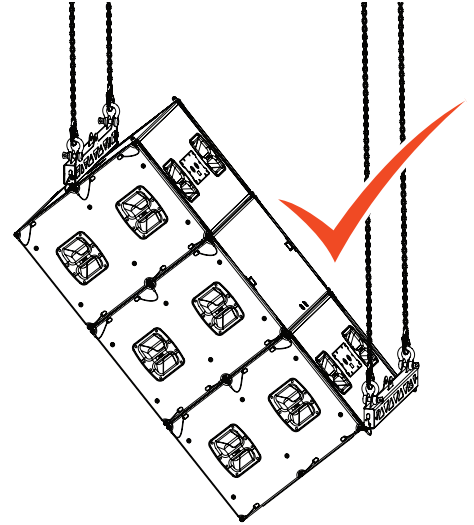

2X VTX A8 SB
QUAD-POINT

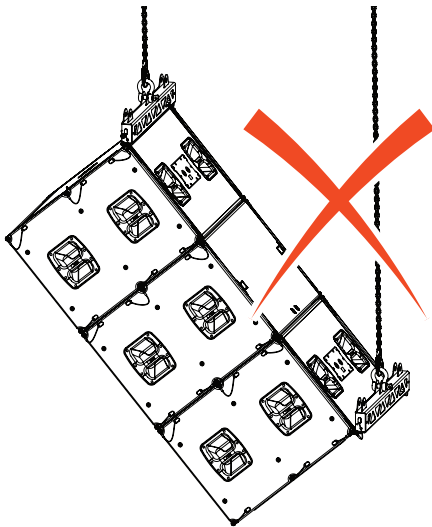

2X VTX A8 SB
DUAL-POINT

1.1 - THE VTX A8 MINI FRAME

The VTX A8 MF Mini Frame is a lightweight, compact, and inexpensive array frame intended for suspending smaller VTX A8 and VTX B18 arrays. The three-piece design is comprised of two side arms and one spreader bar. The side arms connect to the cabinets, and the spreader bar can be pinned to one of the 22 pick-point positions, providing excellent tilt resolution. The Mini Frame was designed to work primarily in single-point applications, although dual-point suspension is supported using the two spreader bar side shackle positions. The Mini Frame can be used in conjunction with the VTX RC500 rotating clamp, allowing smaller A8/B18 arrays to be suspended from standard size trusses or pipes. The three pieces can be collapsed and pinned together for storage.



CAUTION: This manual describes the VTX A8 MF only in the context of the B18. For detailed information on the A8 Mini Frame and full use cases refer to the VTX A8 Rigging Manual before using.

1.1.1 MINI FRAME OVERVIEW

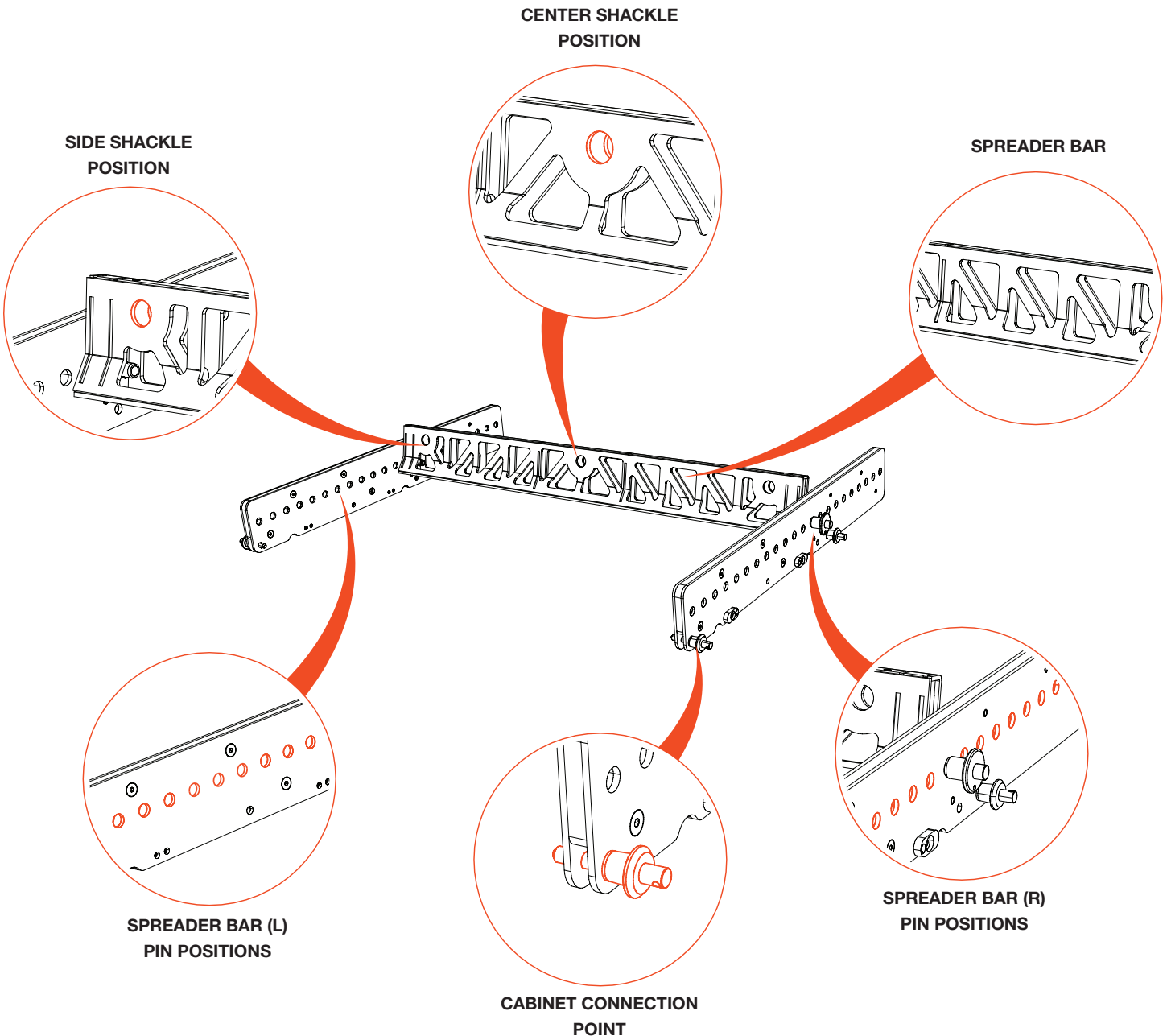

11.2 ATTACHING THE MINI FRAME

The Mini Frame is always attached to the front four rigging bars of the top B18 subwoofer in an array.

STEPS:

- 1 Extend the four front B18 rigging bars by removing the four quick release pins.
- 2 The rigging bars will automatically extend upwards. Once they have, replace the four QRPs to their original positions.

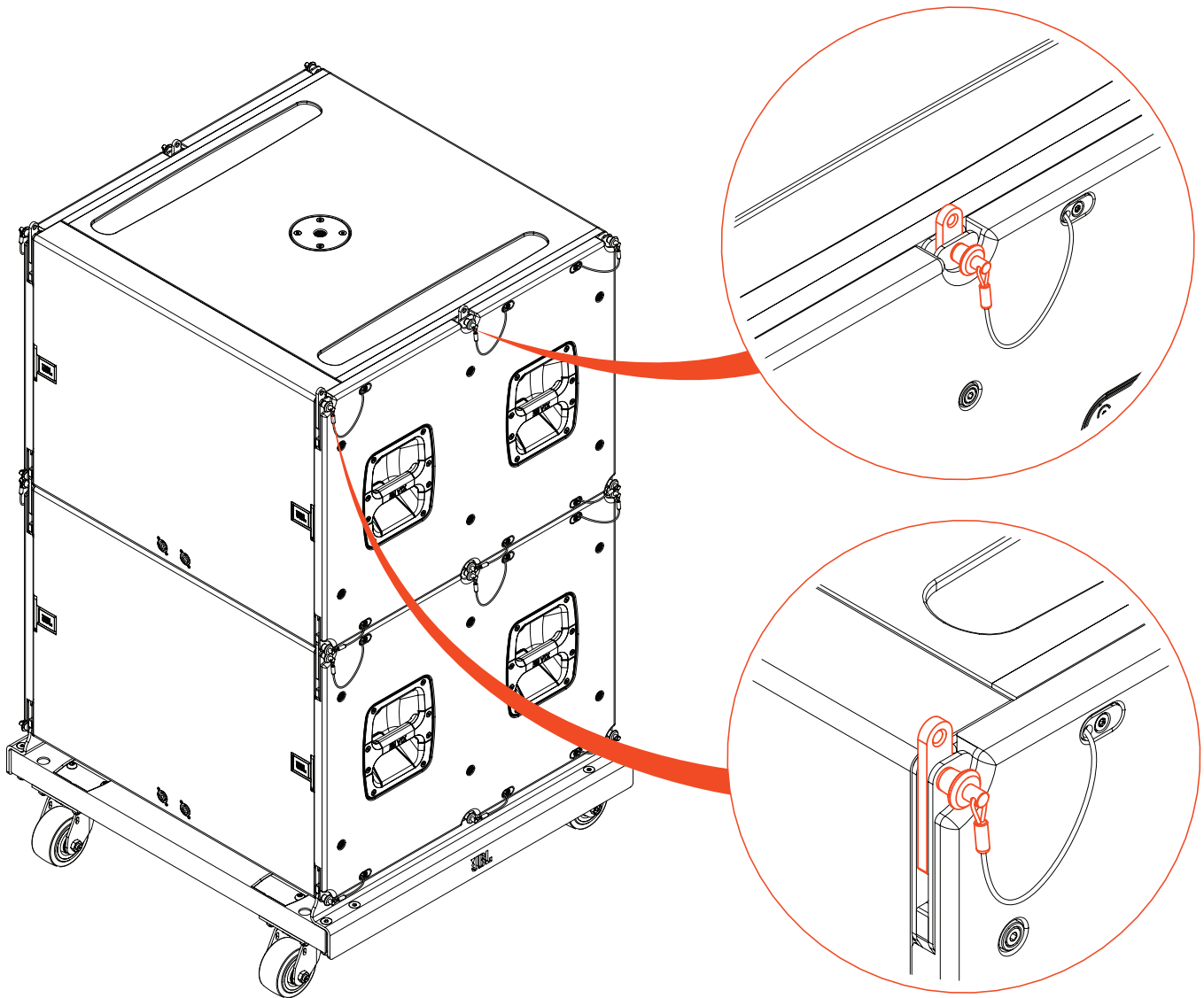

STEPS:

- 1 Attach the two side arms to the B18 using the quick release pins attached to the side arms.
- 2 Pin the spreader bar to the desired pick-point position using the two pins attached to the spreader bar.

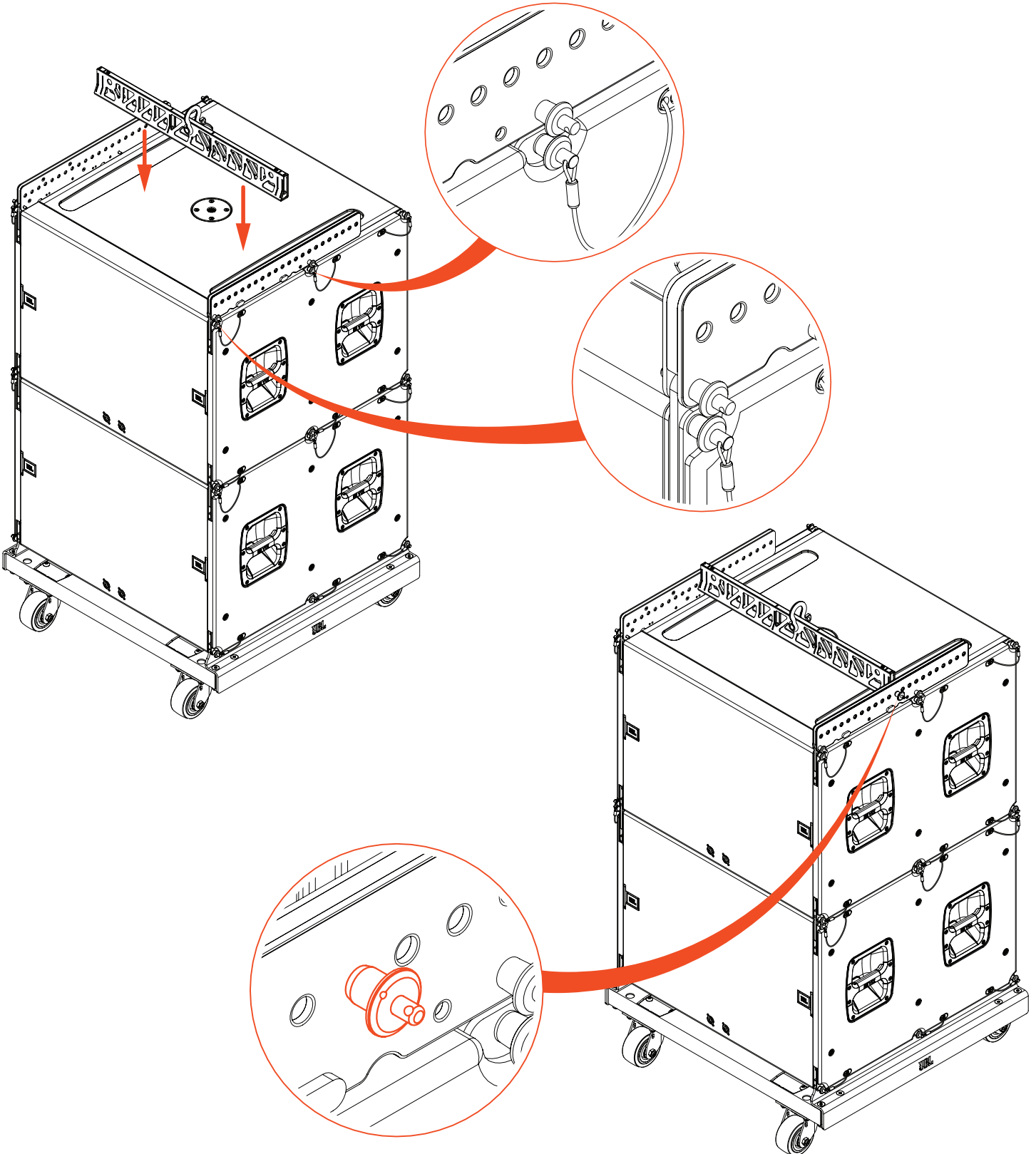

11.3 MINI FRAME SUSPENSION OPTIONS

The VTX A8 Mini Frame can be used in single-point configurations using the center shackle position of the spreader bar. Alternatively, the two side shackle positions can be used to facilitate dual-point configurations. When a single point is used, the side shackle positions can be used for safety attachment and vice-versa.

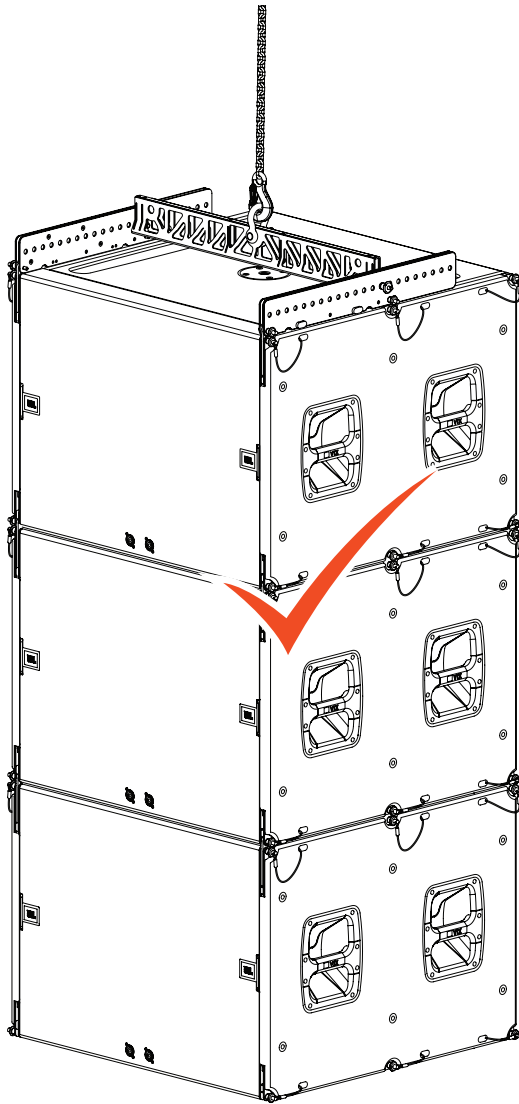

SINGLE-POINT

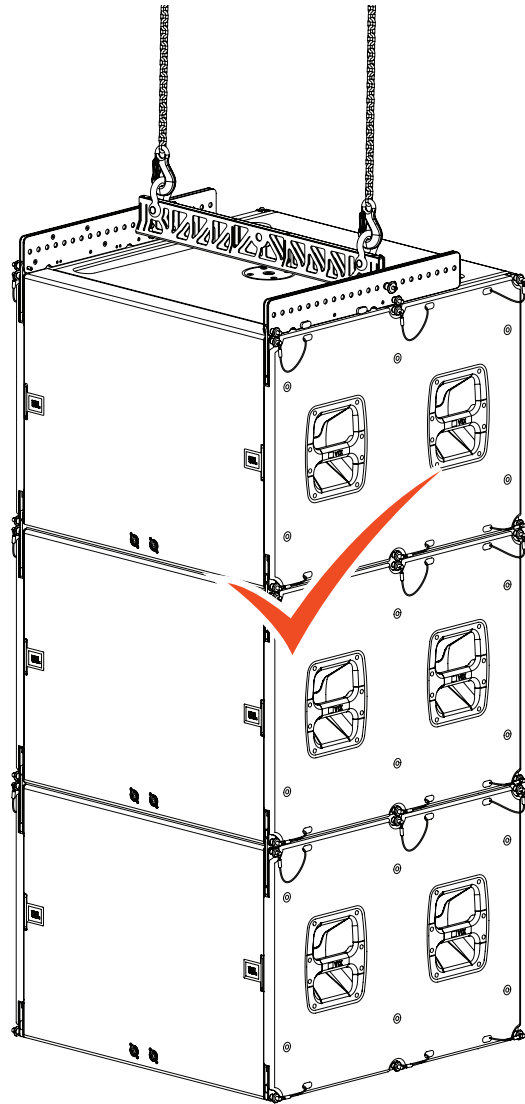

DUAL-POINT
SIDE-BY-SIDE



CAUTION: Always make sure that the same hole position is used on both side arms. Failing to use the same position on both sides can result in damaging the Mini Frame.

11.4 SELECTING SPREADER BAR POSITIONS

Each one of the two Mini Frame side arms includes 22 hole positions used for attaching the spreader bar. The position of the spreader bar controls the overall site angle of the array. The further back the spreader bar is attached, the more down angle is generated and vice-versa. The exact position of the spreader bar for a given angle is determined using Line Array Calculator 3 software. Position 14 corresponds to the Center-of-Gravity position of the B18, and can be used to suspend B18s flat (straight). Position 14 is marked as such on the Mini Frame side arms.

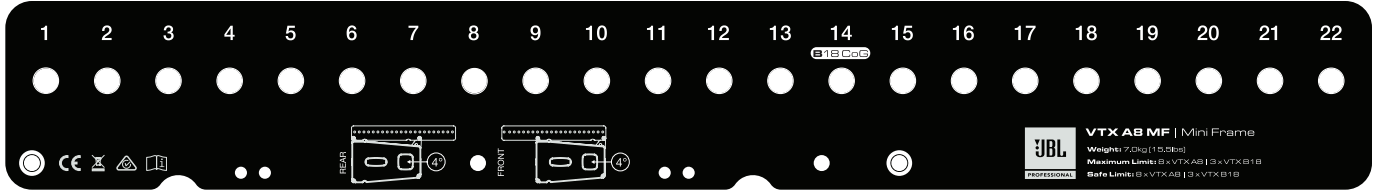

EXAMPLES:

- A** Spreader bar set to position 7, creating uptilt (in this case +29 degrees).
- B** Spreader bar set to position 20, creating downtilt (in this case for a single B18 -29 degrees).

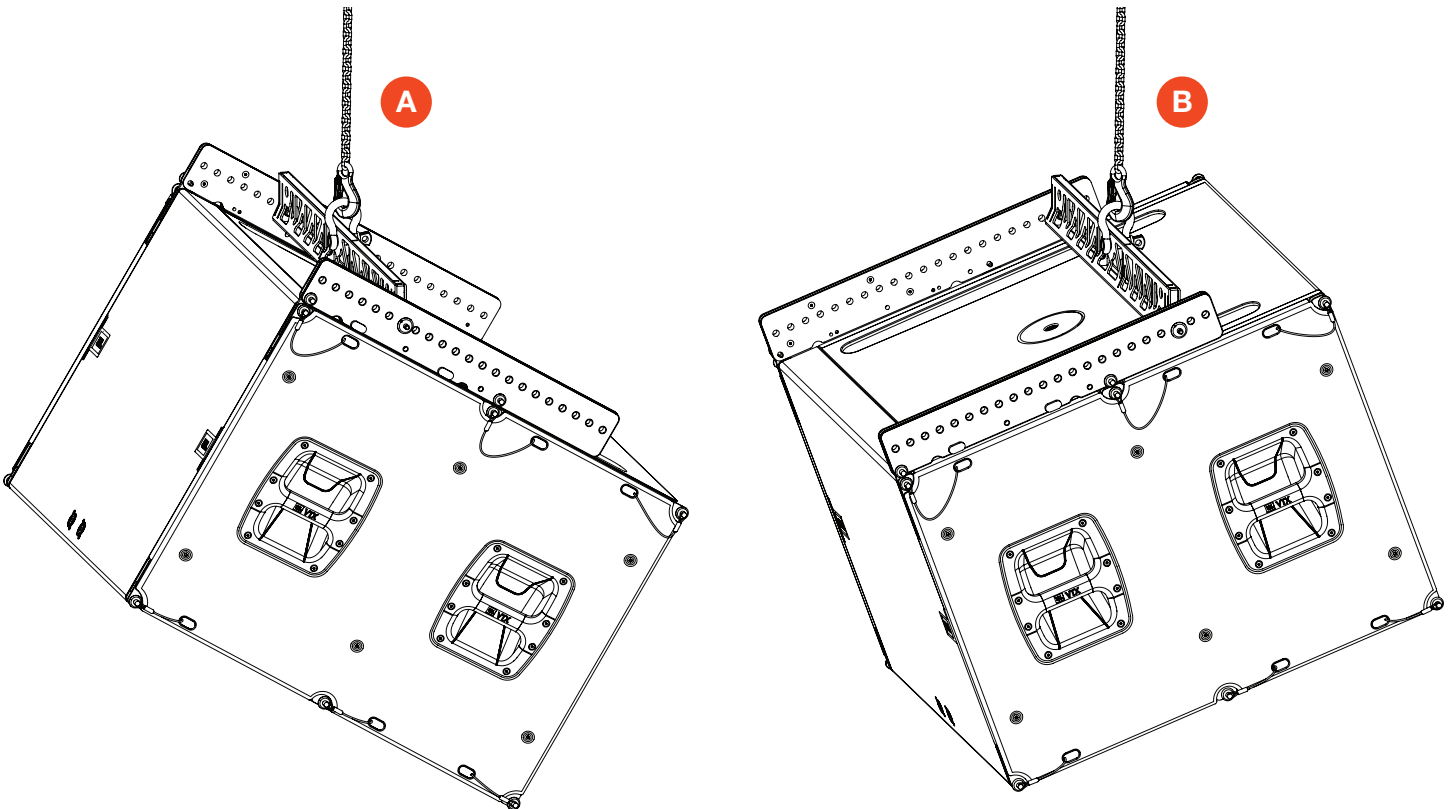

11.5 MINI FRAME AND RC500

The Mini Frame can be used in combination with the VTX RC500 rotating clamp. The VTX RC500 is a universal truss/pipe adapter designed for vertically suspending speaker arrays from standard truss structures or pipes. The RC500 supports arrays of up to 500 kg (1100 lbs) and is compatible with array frames that support 1/2" shackles, such as the VTX A8 MF. The RC500 is attached to the center shackle position of the Mini Frame and allows for 360° rotation. For more information on the RC500, refer to the RC500 User Manual.

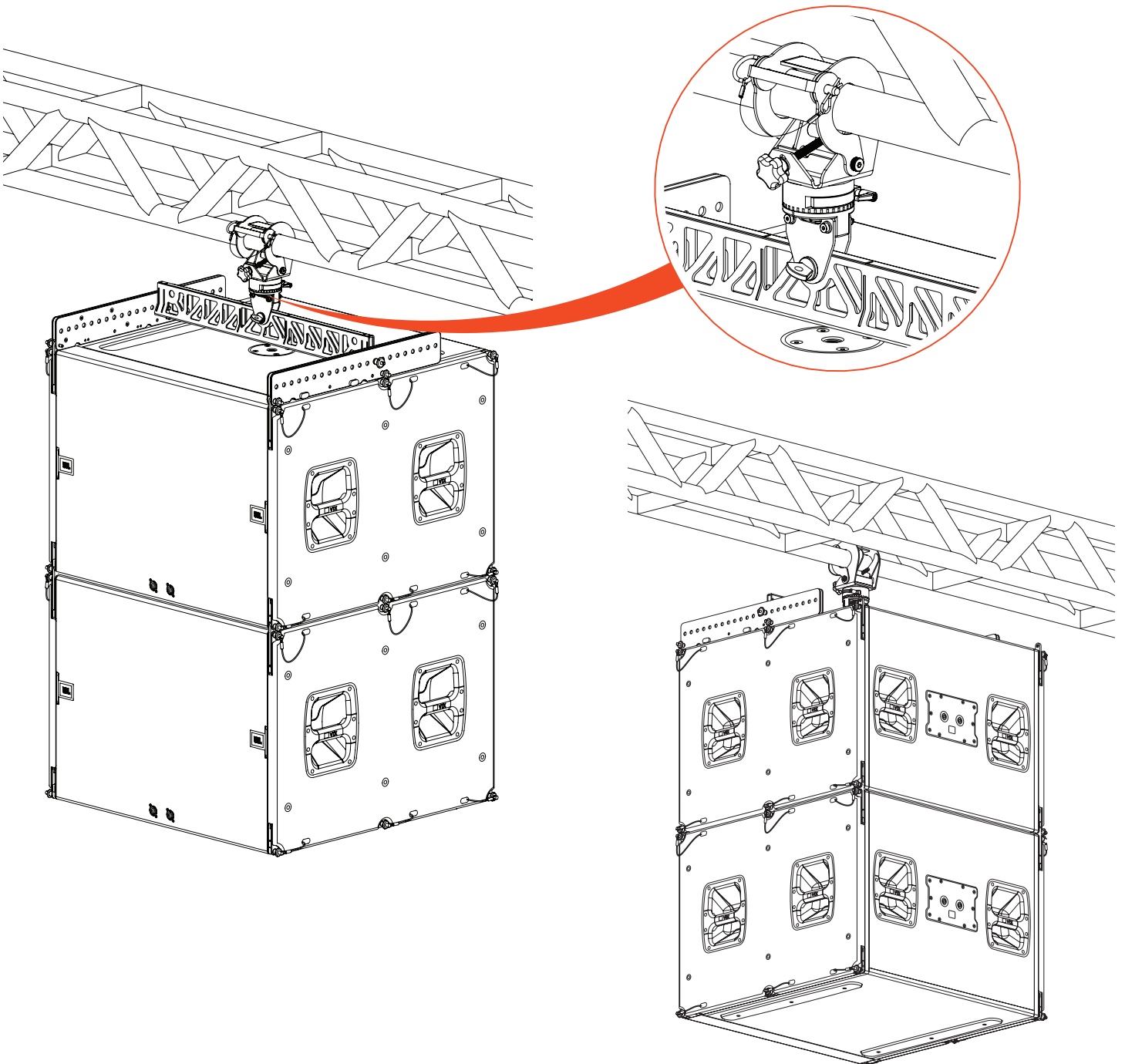

CAUTION: Always make sure that the array weight is within the 500 kg capacity of the RC500. For more information on mechanical limits and use cases, refer to the RC500 User Manual.

12 - M20 POLE MOUNT ATTACHMENT

The B18 includes a standard M20 pole mount plate for attaching extension rods such as the JBL SS5-BK or other JBL-supported accessories, like base plates. This allows the B18 subwoofer to be used with a number of JBL full-range speakers like the VTX F12/F15 or VRX series products. In this configuration, a load of up to **45 kg (100 lbs)** can be placed on the extension rod as a static vertical load. For more information on the A8 Base Plate configuration limits, refer to the VTX A8 Rigging Manual.

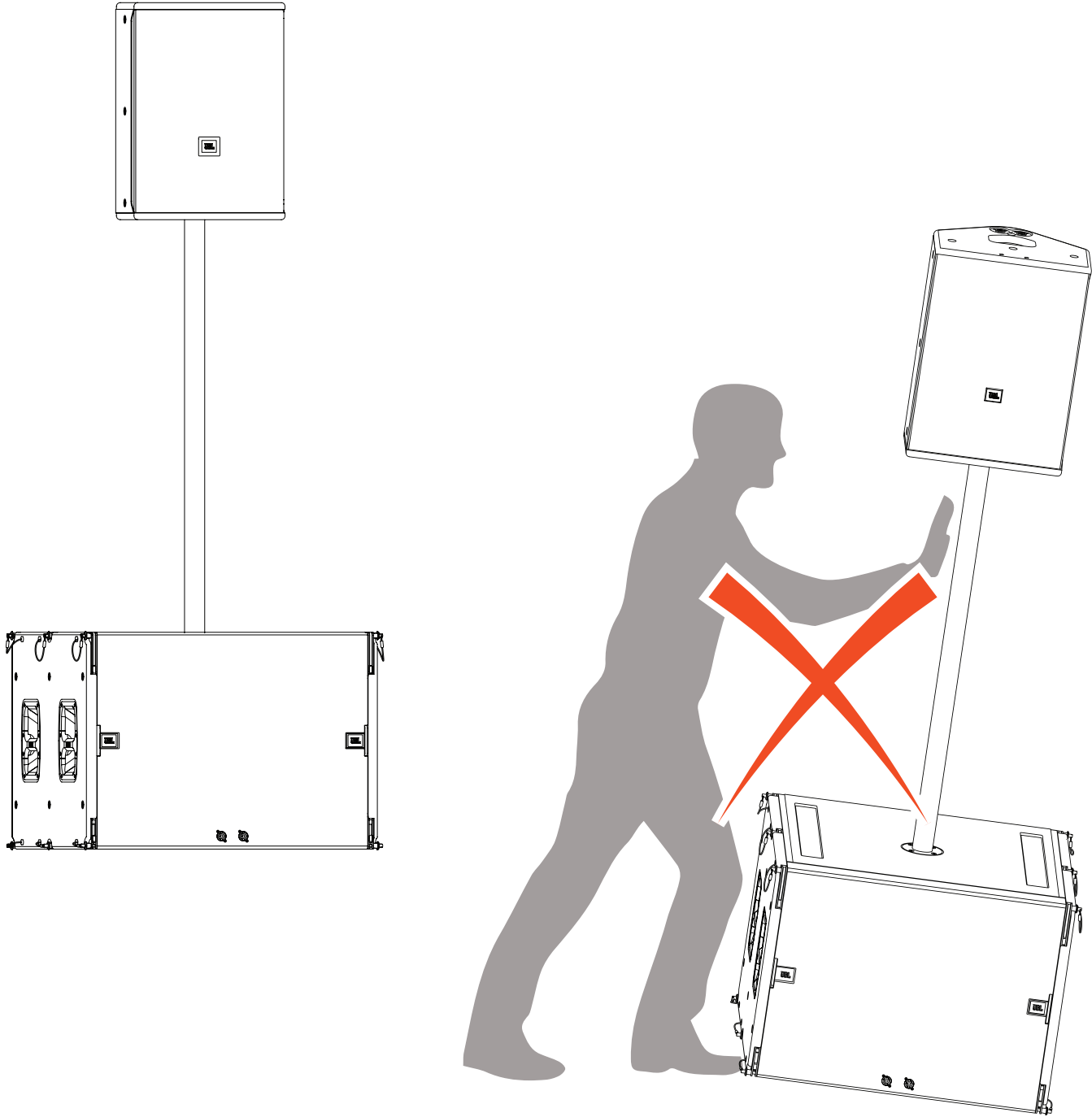

CAUTION: Lifting or pushing the extension rod, or sliding the B28 with a loaded extension rod, is unsafe. This can result in permanent damage or reduce the capacity of the M20 plate, potentially leading to a falling loudspeaker and personal injury.

13 - SPECIFICATIONS

13.1 VTX A8 AF

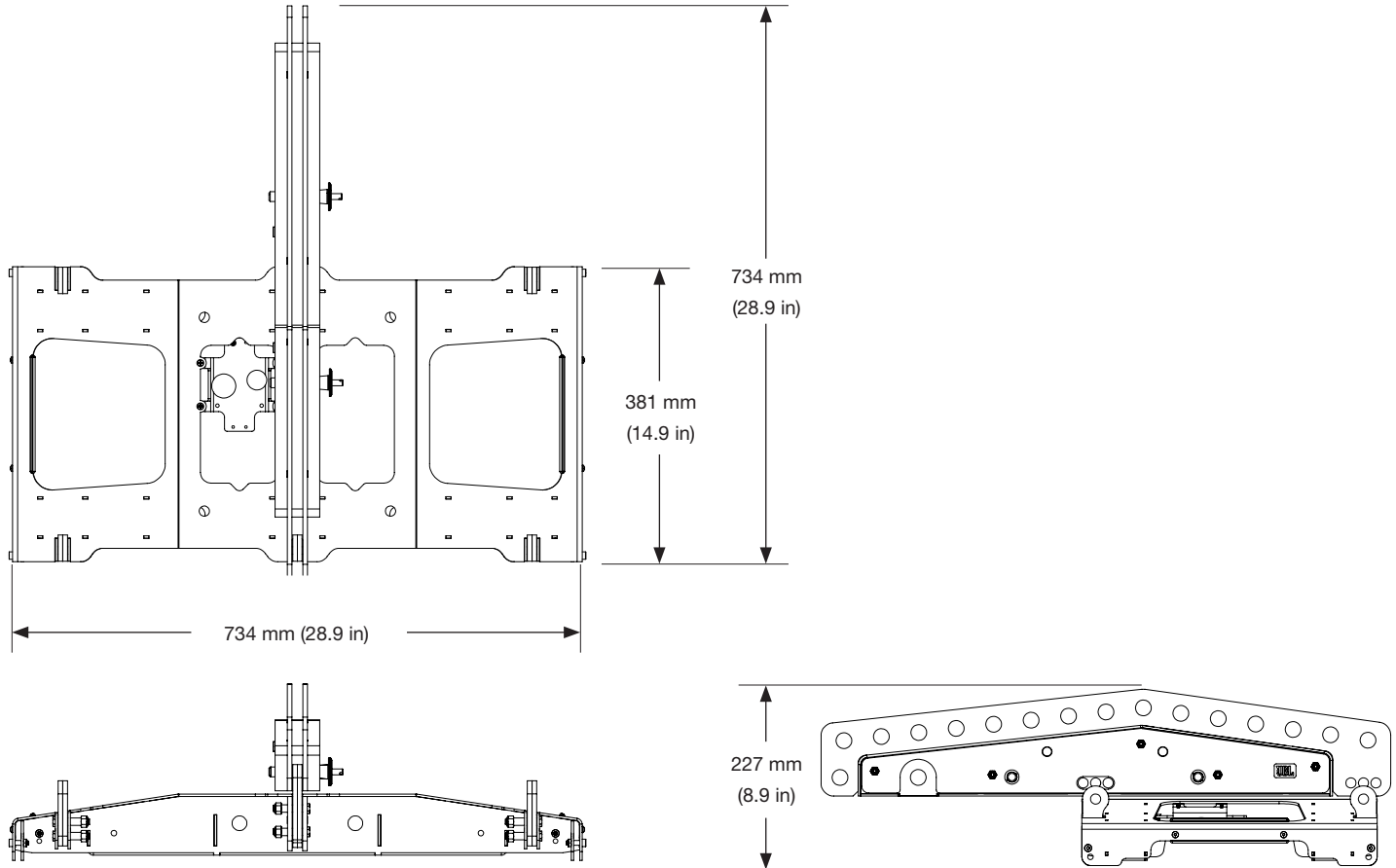

Construction: High-grade steel with anti-corrosion coating

Finish: Black powder coat

Compatible Shackle Size: 5/8 inch

Supported Lasers: JBL VTX LZ, TEQ-SAS, Recline

Mechanical Limits¹

Maximum: (24) VTX A8 | (13) VTX B18

Safe Limit: (22) VTX A8 | (10) VTX B18

Dimensions (H x W x D)²: 227 mm x 734 mm x 734 mm
(8.9 in x 28.9 in x 28.9 in)

Net Weight³: 20.2 kg (44.5 lbs)

Footnotes:

1: For arrays larger than the safe limit always use the JBL Line Array Calculator to determine mechanical safety

2: Refer to the 2D and 3D Customer Drawings for more detailed dimensions

3: Weight includes AF and EB. Shackles and other rigging parts not included

JBL continually engages in research related to product improvement. Some materials, production methods and design refinements are introduced into existing products without notice as a routine expression of that philosophy. For this reason, any current JBL product may differ in some respect from its published description, but will always equal or exceed the original design specifications unless otherwise stated.

13.2 VTX A8 AFEB

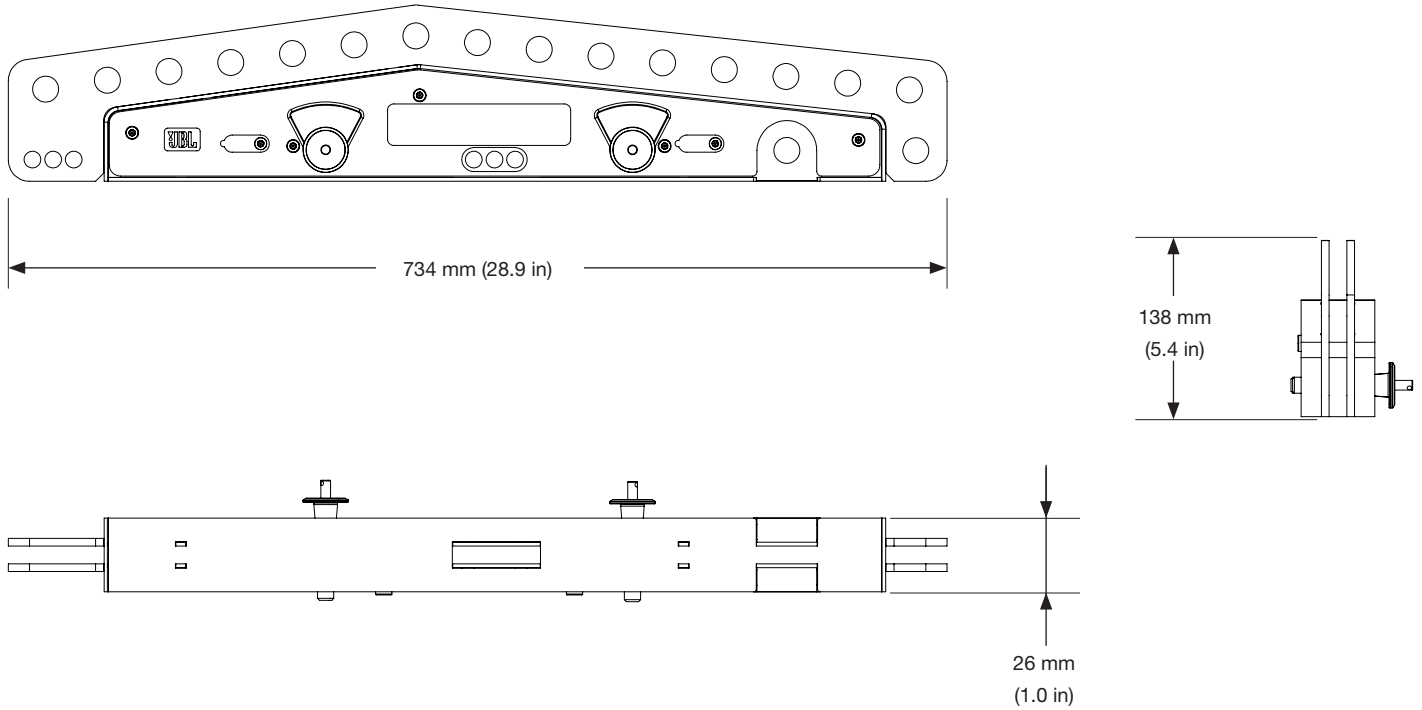

Construction: High-grade steel with anti-corrosion coating

Finish: Black powder coat

Compatible Shackle Size: 5/8 inch

Mechanical Limits¹

Maximum: (24) VTX A8 | (13) VTX B18

Safe Limit: (22) VTX A8 | (10) VTX B18

Dimensions (H x W x D)²: 138 mm x 734 mm x 26 mm
(5.4 in x 28.9 in x 1.0 in)

Net Weight³: 7.5 kg (16.5 lbs)

Footnotes:

1: For arrays larger than the safe limit always use the JBL Line Array Calculator to determine mechanical safety

2: Refer to the 2D and 3D Customer Drawings for more detailed dimensions

3: Weight includes EB only. Shackles and other rigging parts not included

JBL continually engages in research related to product improvement. Some materials, production methods and design refinements are introduced into existing products without notice as a routine expression of that philosophy. For this reason, any current JBL product may differ in some respect from its published description, but will always equal or exceed the original design specifications unless otherwise stated.

13.3 VTX A8 MF

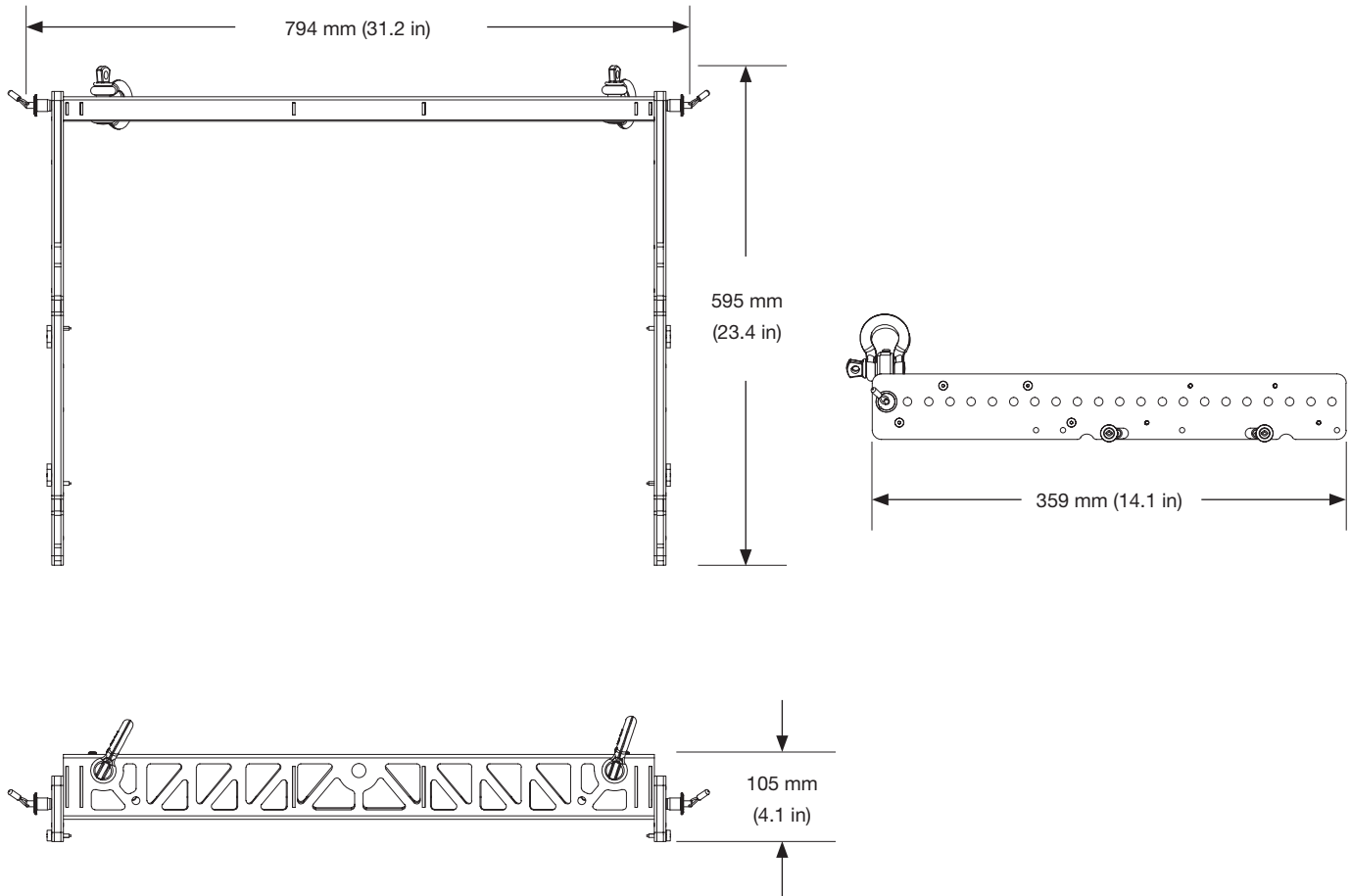

Construction: High-grade steel with anti-corrosion coating

Finish: Black powder

Compatible Shackle Size: 1/2 inch

Mechanical Limits¹

Maximum: (10) VTX A8 | (4) VTX B18

Safe Limit: (10) VTX A8 | (4) VTX B18

Dimensions (H x W x D)²: 105 mm x 794 mm x 595 mm
(4.1 in x 31.2 in x 23.4 in)

Net Weight³: 7.0 kg (15.5 lbs)

Footnotes:

1: For arrays larger than the safe limit always use the JBL Line Array Calculator to determine mechanical safety

2: Refer to the 2D and 3D Customer Drawings for more detailed dimensions

3: Weight includes sidearms and spreader. Shackles and other rigging parts not included

JBL continually engages in research related to product improvement. Some materials, production methods and design refinements are introduced into existing products without notice as a routine expression of that philosophy. For this reason, any current JBL product may differ in some respect from its published description, but will always equal or exceed the original design specifications unless otherwise stated.

13.4 VTX A8 SB

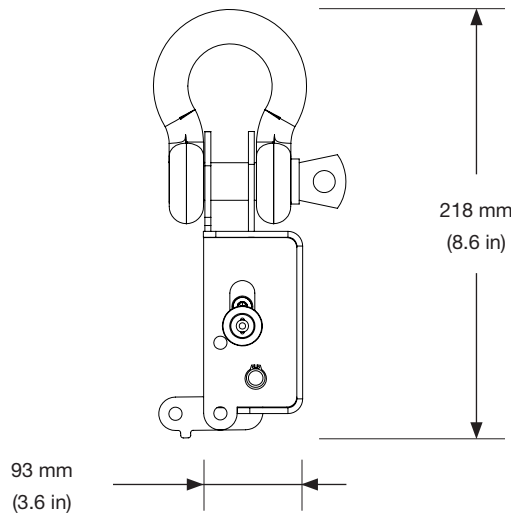
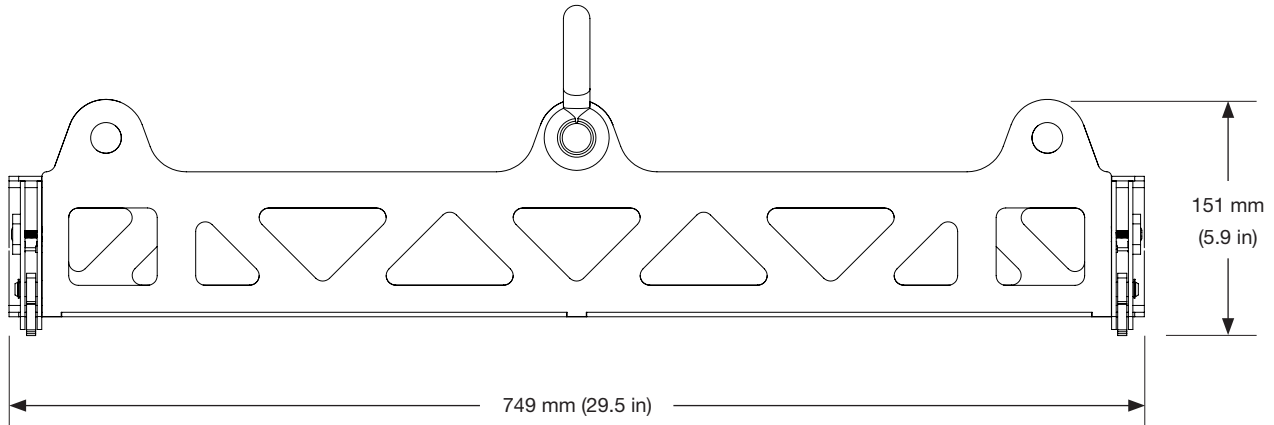

Construction: High-grade steel with anti-corrosion coating

Finish: Black powder coat

Compatible Shackle Size: 5/8 inch

Mechanical Limits¹

Maximum: (24) VTX A8 | (16) VTX B18

Safe Limit: (12) VTX A8 | (14) VTX B18

Dimensions (H x W x D)²: 151 mm x 749 mm x 93 mm
(5.9 in x 29.5 in x 6.6 in)

Net Weight³: 4.8 kg (10.58 lbs)

Footnotes:

1: Refer to the 2D and 3D Customer Drawings for more detailed dimensions

2: Shackles and other rigging parts not included

JBL continually engages in research related to product improvement. Some materials, production methods and design refinements are introduced into existing products without notice as a routine expression of that philosophy. For this reason, any current JBL product may differ in some respect from its published description, but will always equal or exceed the original design specifications unless otherwise stated.

13.5 VTXB18 VT

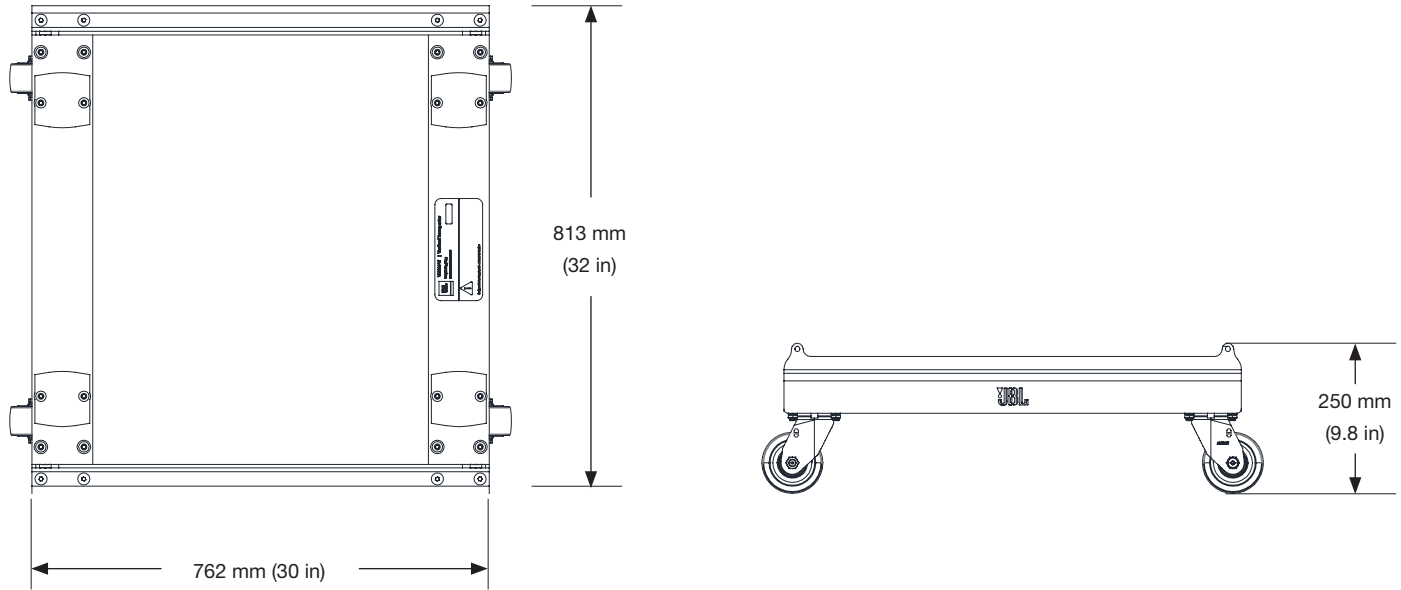

Construction: High-grade steel with anti-corrosion coating, aluminum

Finish: Black powder coat

Mechanical Limits

Maximum: (4) VTX B18

Dimensions (H x W x D)¹: 250 mm x 813 mm x 76 mm
(9.8 in x 32 in x 30 in)

Net Weight²: 22 kg (49 lbs)

Footnotes:

- 1: Refer to the 2D and 3D Customer Drawings for more detailed dimensions
- 2: Shackles and other rigging parts not included

JBL continually engages in research related to product improvement. Some materials, production methods and design refinements are introduced into existing products without notice as a routine expression of that philosophy. For this reason, any current JBL product may differ in some respect from its published description, but will always equal or exceed the original design specifications unless otherwise stated.

13.6 VTXB18 ACC

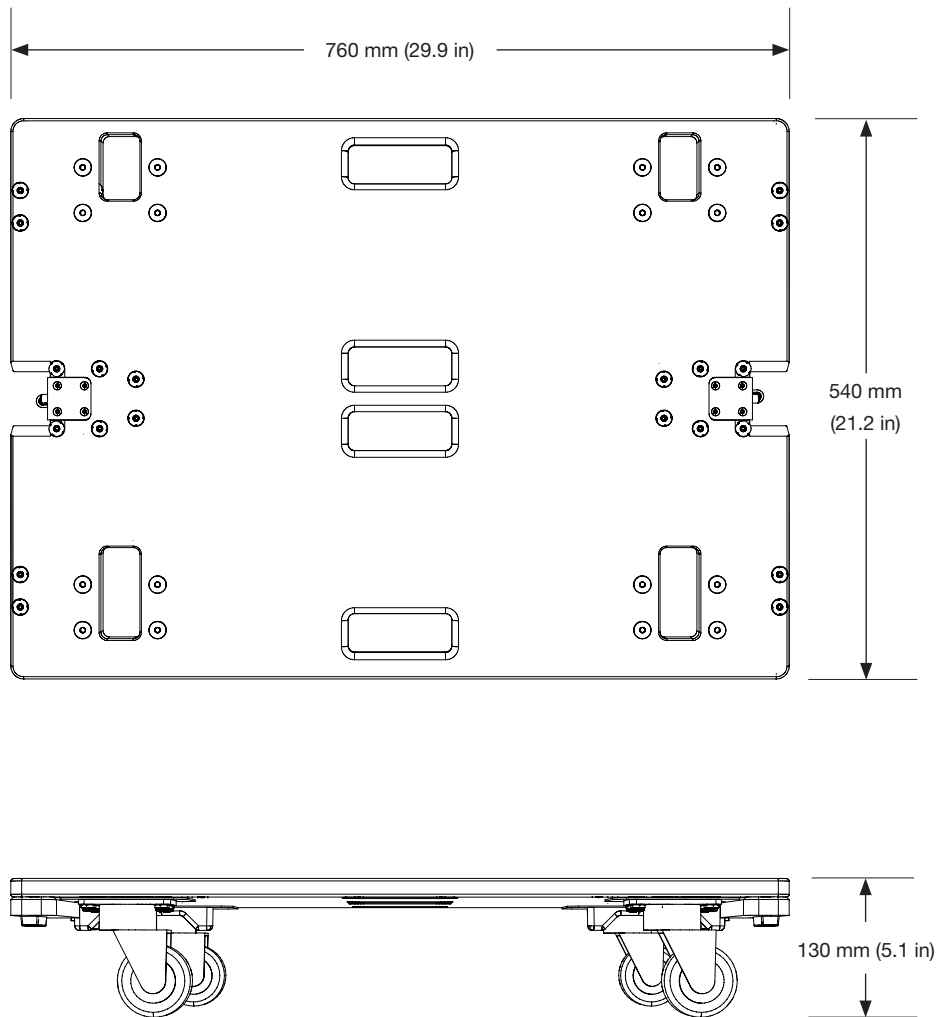

Construction: Board: exterior grade birch plywood
Hardware: stainless steel/zinc plated steel

Finish: Black JBL Duraflex™ finish

Dimensions (H x W x D)¹: 130 mm x 760 mm x 540 mm
(5.1 in x 29.9 in x 21.2 in)

Net Weight²: 10.1 kg (22.4 lbs)

Footnotes:

1: Refer to the 2D and 3D Customer Drawings for more detailed dimensions

2: Weight includes caster-board and soft-cover

JBL continually engages in research related to product improvement. Some materials, production methods and design refinements are introduced into existing products without notice as a routine expression of that philosophy. For this reason, any current JBL product may differ in some respect from its published description, but will always equal or exceed the original design specifications unless otherwise stated.

13.7 - VTX B1 GND

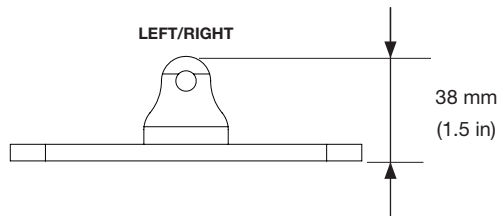
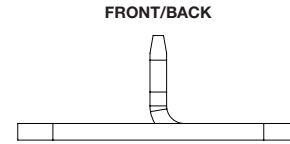
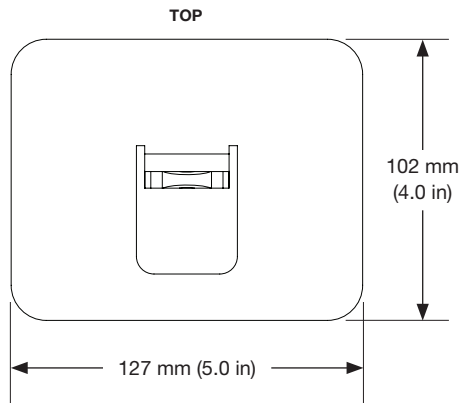

PHYSICAL

Construction : High-grade steel with anti-corrosion coating

Finish : Black powder coat

Dimensions (H x W x D)¹ : 38 mm x 102 mm x 127 mm
(1.5 in x 4.0 in x 5.0 in)

Net Weight : 0.5 kg (1.2 lbs) each | 2.0 kg (4.8 lbs) total
Shipping Weight : 2.9 kg (6.5 lbs)

ORDERING INFORMATION

SKU : JBL-P3258MX | VTX B1 GND

Included : (4) Ground stack plates

Footnotes:

1: Refer to the 2D and 3D Customer Drawings for more detailed dimensions.

JBL continually engages in research related to product improvement. Some materials, production methods and design refinements are introduced into existing products without notice as a routine expression of that philosophy. For this reason, any current JBL product may differ in some respect from its published description, but will always equal or exceed the original design specifications unless otherwise stated.

14 - CONTACT INFORMATION

UNITED STATES OF AMERICA

HARMAN Professional Solutions

8500 Balboa Blvd.
Northridge, CA 91329
USA
+1 (844) 776-4899
www.jblpro.com

U.S.A. Technical Support

+1 (844) 776-4899
HProTechSupportUSA@Harman.com
www.jblpro.com

PROFESSIONAL CONTACTS, OUTSIDE THE U.S.A.:

Contact the JBL Professional distributor in your area. A complete list of JBL Professional international distributors is provided at our U.S.A. website: www.jblpro.com

HARMAN Professional EMEA

Westside
London Road
Hemel Hempstead
HP3 9TD
United Kingdom
www.pro.harman.com
www.jblpro.com/support

HARMAN Professional APAC

108 Pasir Panjang Road
#02-08 Golden Agri Plaza
Singapore 118535
+65 6870-5000
www.pro.harman.com
www.jblpro.com/support

HARMAN Professional China

20F, China Merchants Port Plaza, #1
Gongye 3rd Road, Shekou, Nanshan
Dist.
Shenzhen, 518067, China
400 166 7806
www.harman.com/China
www.jblpro.com/support

China In-Country Support

ChinaPRO.Service@harman.com

HARMAN Professional India

Prestige Technology Park
Jupiter 2A Block, 4th Floor
Marathahalli Ring Road
Bangalore 560103, India
+1 (800) 208-8880
www.harman.com/India
www.jblpro.com/support

HARMAN Professional Brazil

Br386, Km435 92480-000
Nova Santa Rita Rs
Brazil
+55 51 34794000
www.harman.com/Brasil
www.jblaudio.com.br
www.jblpro.com/support

India In-Country Support

www.harman.com/india/india-service-center

Brazil In-Country Support

tecnica@harman.com

JBL

PROFESSIONAL