

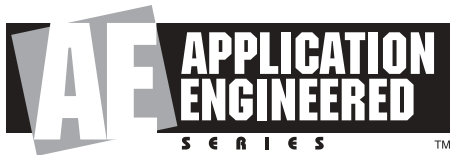

AM4215/64 2-Way Loudspeaker with 1 x 15" LF & Rotatable Horn



Key Features:

- ▶ 60° x 40° Coverage, rotatable for use in either vertical or horizontal orientation.
- ▶ Large PT™ Progressive Transition™ Waveguide for excellent pattern control with low distortion.
- ▶ Bi-Amp/Passive Switchable
- ▶ Optional U-Bracket for easy installation (see AE Series Bracket Guide).

Applications:

- ▶ Small performing arts facilities
- ▶ Theatrical sound design
- ▶ Auditoriums
- ▶ Houses of worship
- ▶ Sports facilities
- ▶ Themed entertainment venues
- ▶ Delay/fill locations of larger systems

AM4215/64 is a medium power 2-way full-range loudspeaker system comprised of one 380 mm (15 in) low frequency driver and one 38 mm (1.5 in) exit/38 mm (1.5 in) voice-coil compression driver. The large PT Progressive Transition waveguide provides well-controlled 60° by 40° coverage and is rotatable for cabinet positioning in either horizontal or vertical orientation. High-slope crossovers minimize band overlap and well-controlled off-axis response enhances arrayability.

The cabinet is fitted with M10 threaded suspension points. Optional U-bracket is available for easy installation.

AM4215/64 is part of JBL's AE Application Engineered Series, a versatile family of loudspeakers for a wide variety of fixed installation applications.



Specifications:

System:	
Frequency Range ¹ (-10 dB):	40 Hz – 20 kHz
Frequency Response ² (±3 dB):	45 Hz – 18 kHz
Coverage Pattern:	60° x 40°, rotatable waveguide
Directivity Factor (Q):	22.4
Directivity Index (DI):	13.5 dB
Crossover Modes:	Bi-amp/Passive switchable
Passive Crossover Slopes:	4th order (24 dB/oct) Linkwitz-Riley HP & LP, 1.3 kHz
Transducer Power Rating (AES):	LF: 500 W (2000 W peak), 2 hrs 350 W (1400 W peak), 100 hrs HF: 35 W (140 W peak), 2 hrs
Long-Term System Power Rating (IEC):	Passive mode: 350 W (1400 W peak), 100 hrs
Maximum SPL:	Bi-amp mode: LF: 124 dB-SPL cont avg (130 dB peak) HF: 130 dB-SPL cont avg (136 dB peak) Passive mode: 124 dB-SPL cont avg (130 dB peak)
System Sensitivity ³ (1W @ 1m):	Passive mode: 97 dB SPL
Transducers:	
Low Frequency Driver:	1 x JBL 2033H 380 mm (15 in) driver with 75 mm (3 in) voice coil
Nominal Impedance:	8 ohms
Sensitivity ⁴ (1W @ 1m, within operational band):	97 dB SPL
High Frequency Driver:	JBL 2407H/MTA, 38 mm (1.5 in) exit compression driver, 38 mm (1.5 in) voice coil
Nominal Impedance:	8 ohms
Sensitivity (1W @ 1m):	115 dB SPL
Waveguide:	PT-H64HF
Physical:	
Enclosure:	Trapezoidal with 15 degree side angles, 16 mm (5/8 in) exterior grade 11-ply Finnish birch plywood
Suspension Attachment:	15 points (4 top, 4 bottom, 2 each side, 3 rear), M10 threaded hardware
Finish:	Black DuraFlex™ finish. White available upon request.
Grille:	Powder coated 14 gauge perforated steel, with acoustically transparent black foam backing.
Input Connector:	NL4 Neutrik Speakon® and CE-compliant covered barrier strip terminals. Barrier terminals accept up to 5.2 sq mm (10 AWG) wire or max width 9 mm (.375 in) spade lugs. Speakon in parallel with barrier strip for loop-through.
Environmental Specifications:	Mil-Std 810; IP-x3 per IEC529.
Dimensions (H x W x D in vertical cabinet orientation):	783 x 422 x 504 mm (30.9 x 16.6 x 19.9 in)
Net Weight:	29.0 kg (64 lb)
Optional Accessories:	M10 x 35 mm forged shoulder eyebolts with washers U-Bracket MTU-1

¹Bi-amp mode, with recommended active tuning.

²Resultant engineered acoustical response of crossover network and components.

³AES standard, one decade pink noise with 6 dB crest factor within device's operational band, free air. Standard AES 2 hr rating plus long-term 100 hr rating are specified for low-frequency transducers.

⁴IEC standard, full bandwidth pink noise with 6 dB crest factor, 100 hours.

⁵Calculated based on power rating and sensitivity, exclusive of power compression.

⁶Anechoic sensitivity in free field, no additional sensitivity gain from boundary loading.

JBL continually engages in research related to product improvement. Changes introduced into existing products without notice are an expression of that philosophy.

AM4215/64 2-Way Loudspeaker with 1 x 15" LF & Rotatable Horn

Beamwidth

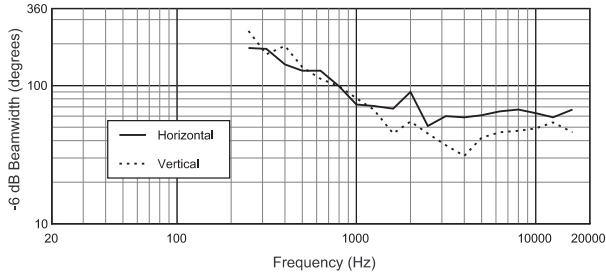

Horizontal Off-Axis Frequency Response

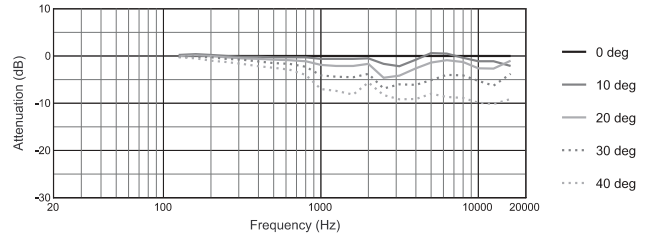

Directivity Index, Q

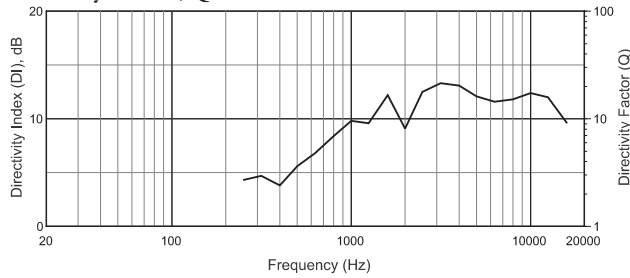

Vertical Up Off-Axis Frequency Response

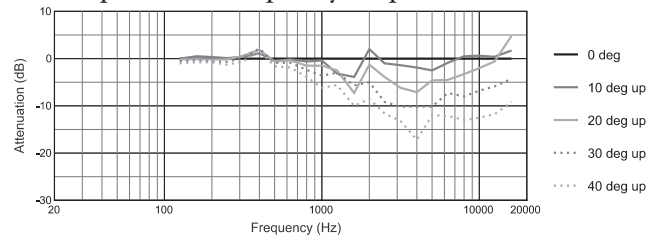

Dimensions

Dimensions in mm (in)

For more detailed dimensional information, refer to Application Data Sheet

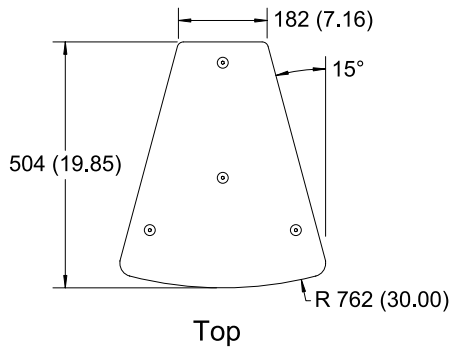

Vertical Down Off-Axis Frequency Response

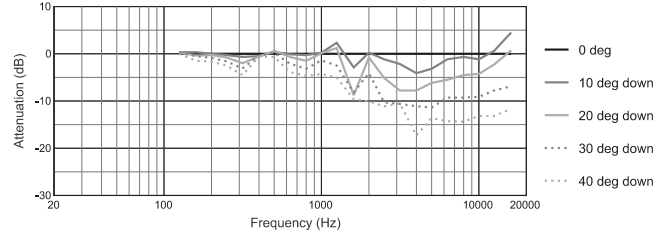

Measurements obtained in full passive crossover mode with no signal processing. Graphs are from unaltered measured data.

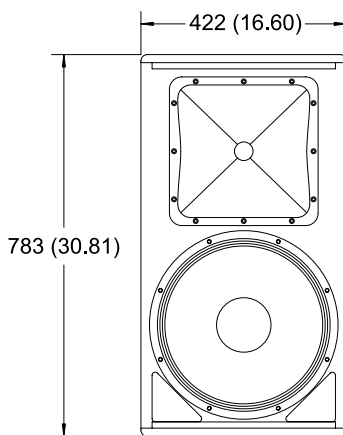

Front

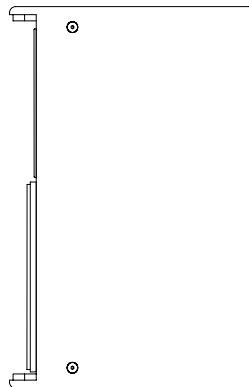

Side

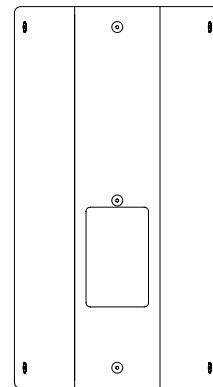

Back

Horizontal 1/3 Octave Polars

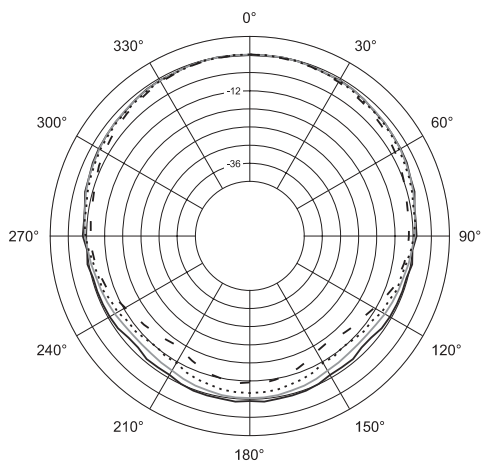

- 200Hz
- - 250Hz
- 315Hz

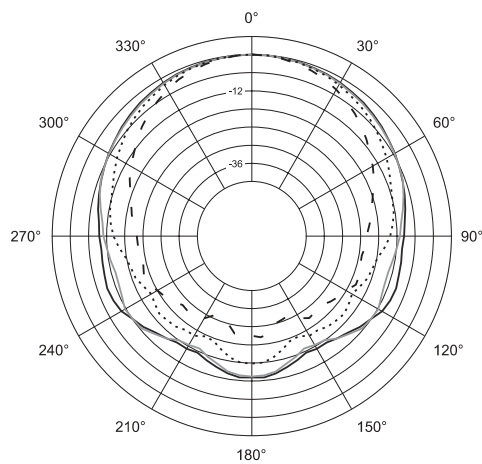

- 500Hz
- - 630Hz
- 800Hz

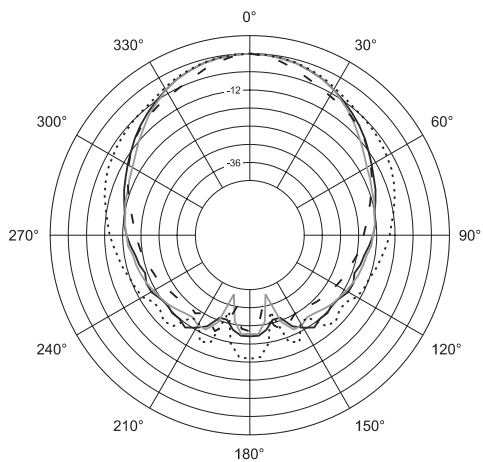

- 1.25kHz
- - 1.6kHz
- 2kHz

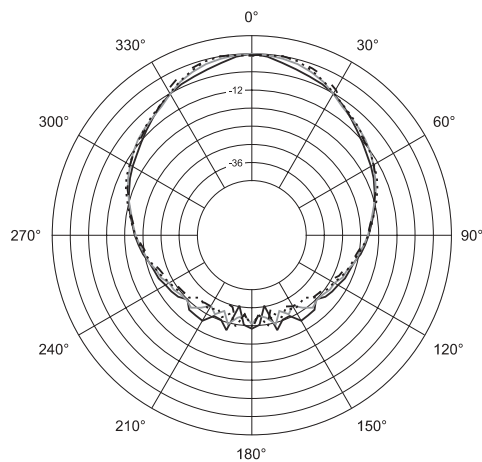

- 3.15kHz
- - 4kHz
- 6.3kHz

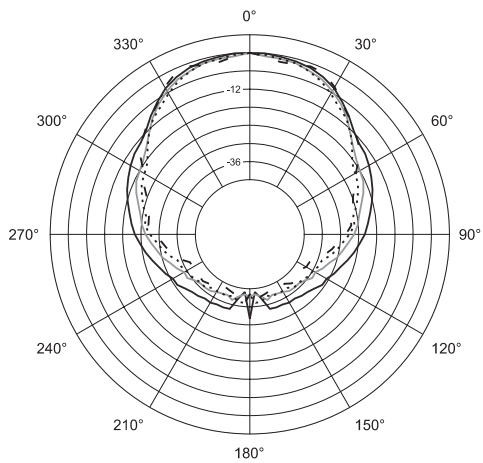

- 8kHz
- - 10kHz
- 12.5kHz
- . 16kHz

▶ AM4215/64 2-Way Loudspeaker with 1 x 15" LF & Rotatable Horn

Vertical 1/3 Octave Polars

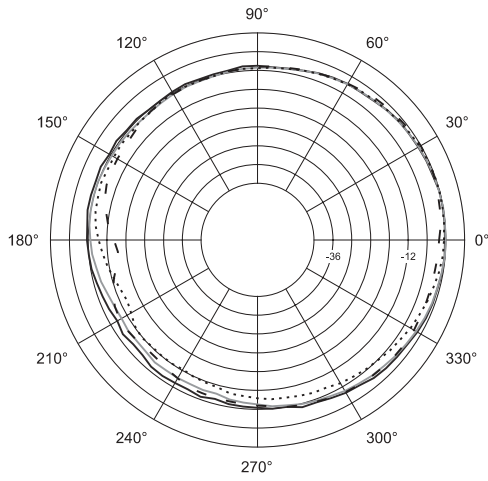

- 200Hz
- 250Hz
- 315Hz
- - 400Hz

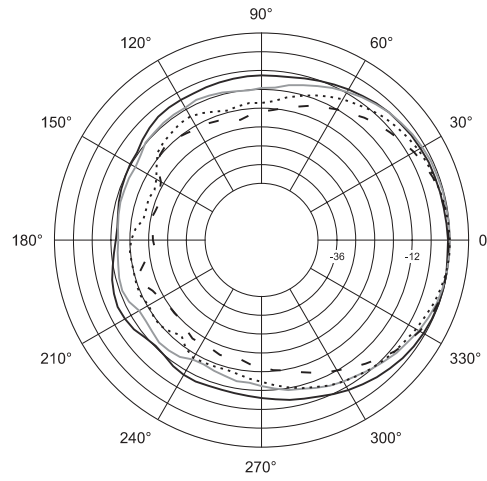

- 500Hz
- 630Hz
- 800Hz
- - 1kHz

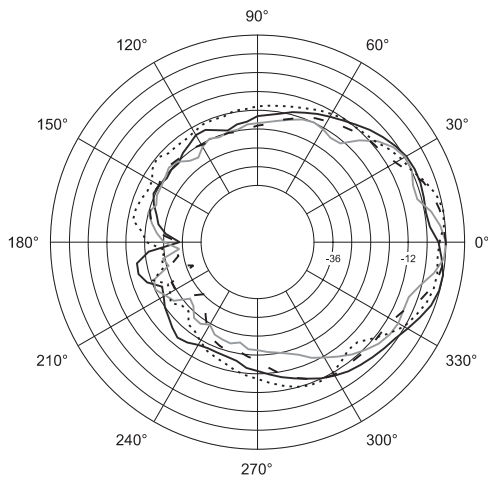

- 1.25kHz
- 1.6kHz
- 2kHz
- - 2.5kHz

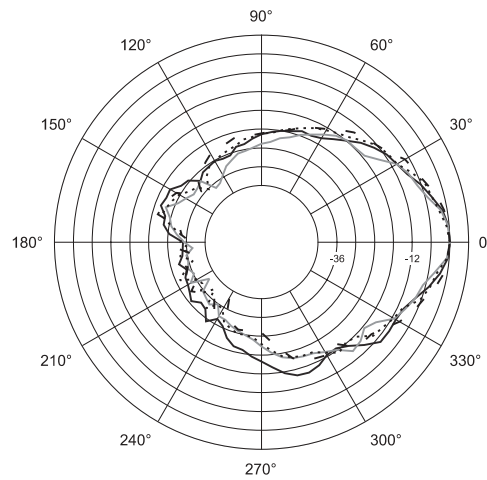

- 3.15kHz
- 4kHz
- 5kHz
- - 6.3kHz

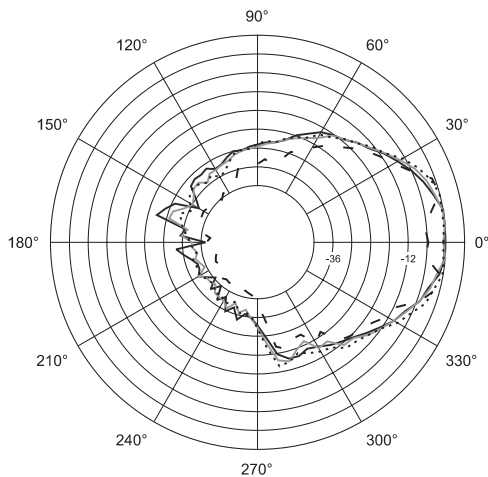

- 8kHz
- 10kHz
- 12.5kHz
- - 16kHz



JBL Professional
 8500 Balboa Boulevard, P.O. Box 2200
 Northridge, California 91329 U.S.A.

■ A Harman International Company
 © Copyright 2002 JBL Professional

SS AM4215/95
 CRP ??M
 9/02