

# 8350 Very High Power Cinema Surround Speaker for Digital Applications

## Professional Series

### Key Features:

- ▶ 60 Hz to 19 kHz Frequency Range
- ▶ High Sensitivity, 97 dB SPL, 1 W, 1 m (3.3 ft)
- ▶ High Power Handling Capability: 350 watts continuous pink noise
- ▶ Convenient mounting design uses JBL QuickMount™, Omnimount® or APC Multimount brackets
- ▶ Special cabinet shape incorporates 20° angled front baffle
- ▶ SMPTE/ISO2969 Curve X high frequency de-emphasis
- ▶ Lightweight, rigid molded enclosure
- ▶ Input terminals located on top of cabinet for quick access
- ▶ Uniform horizontal and vertical coverage
- ▶ THX® Approved

The 8350 Cinema Surround Speaker offers very high power handling, high sensitivity, and extended bass response in a very compact enclosure. The two-way 8350's reliability and performance features position it as the ideal high power surround for the extended dynamic range required by digital sound formats.

The 8350 features a high power, long-throw 250 mm (10 in) low frequency driver for smooth, extended bass response. The high frequency section combines a 38 mm (1.5 in) coil diameter compression driver with a constant coverage horn for very high output capability and wide, even high frequency coverage. The 350 watt continuous power rating (1400 watt peak) provides extended dynamic range required for digital soundtracks with absolute reliability.

Its modern, molded black textured enclosure with black grille enhances any decor.

JBL's QuickMount bracket allows one person to quickly and simply mount the very lightweight enclosure on a previously installed bracket half.

Built to traditional JBL quality standards, the 8350 will stand up to long-term use under adverse conditions while delivering excellent performance.

Omnimount is a registered trademark of Omnimount Systems.

THX is a trademark of THX Ltd. which may be registered in some jurisdictions. All rights reserved.



### Specifications:

#### System:

Frequency Range (-10 dB):	60 Hz - 19 kHz
Frequency Response (±3 dB):	75 Hz - 17 kHz
Power Rating <sup>1</sup> :	350 watts continuous pink noise, 1400 watts peak
Sensitivity (1W/1m) <sup>2</sup> :	99 dB-SPL half-space / wall-mounted 97 dB-SPL free-field
Maximum Peak SPL <sup>3</sup> :	130 dB/1m
Nominal Impedance:	8 ohms
Hor. Coverage Angle (-6 dB):	100° averaged 400 Hz to 12 kHz
Vert. Coverage Angle (-6 dB):	80° averaged 400 Hz to 12 kHz
Directivity Factor (Q):	7 averaged 400 Hz to 12 kHz
Directivity Index (DI):	8.4 dB averaged 400 Hz to 12 kHz
Crossover Frequency:	1.4 kHz
High Frequency Contour:	ISO2969 Curve X surround contour
Polarity:	EIA (Positive voltage to RED terminal gives forward cone motion)

#### Low Frequency Transducer:

Nominal Diameter:	250 mm (10 in) 64 mm (2.5 in) voice coil
-------------------	---------------------------------------------

#### High Frequency Transducer:

Nominal Diameter:	25 mm (1 in) exit 38 mm (1.5 in) voice coil
-------------------	------------------------------------------------

#### Physical:

Downward Firing Angle:	Nominal 20° when mounted flush on back panel
Enclosure Material:	Textured Black H.I.P.S. Plastic
Grille Color:	Black
Input Connectors:	5-way binding posts
Dimensions (H x W x D):	457 mm x 457 mm x 260 mm (18 in x 18 in x 10.25 in)
Net Weight:	9.5 kg (21 lb)

<sup>1</sup>Rating based on test signal of IEC filtered random noise with a peak-to-average ratio of 6 dB, two hours duration.

<sup>2</sup>Average measured free-field and half-space sensitivity at 2.83V/1m from 200 Hz to 3 kHz.

<sup>3</sup>Calculated maximum SPL based on rated power handling and half-space sensitivity.

JBL continually engages in research related to product improvement. Some materials, production methods and design refinements are introduced into existing products without notice as a routine expression of that philosophy. For this reason, any current JBL product may differ in some respect from its published description, but will always equal or exceed the original design specifications unless otherwise stated.

# ► 8350 Very High Power Cinema Surround Speaker for Digital Applications

Frequency Response in half-space ( $2\pi$ , solid line) and full-space ( $4\pi$ , dotted line), and Input Impedance

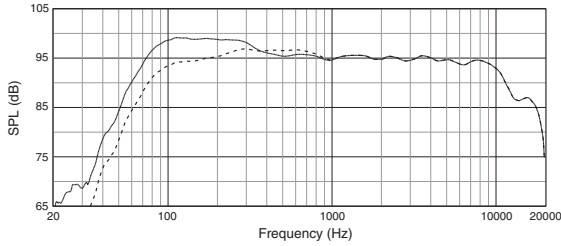

Beamwidth vs. Frequency

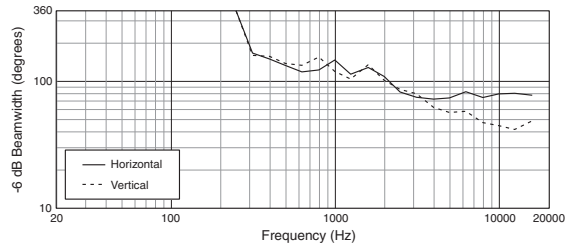

Horizontal Off-Axis Frequency Response

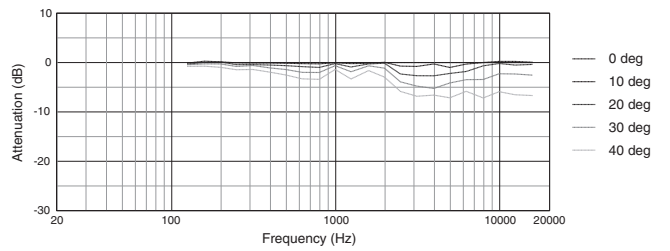

Vertical Off-Axis Frequency Response (down)

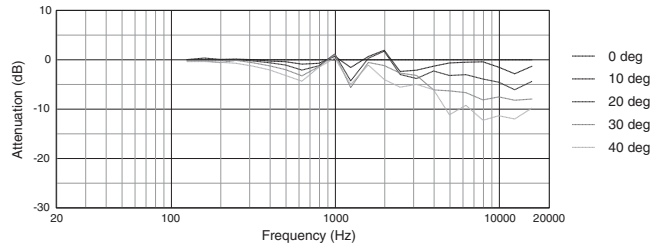

Impedance

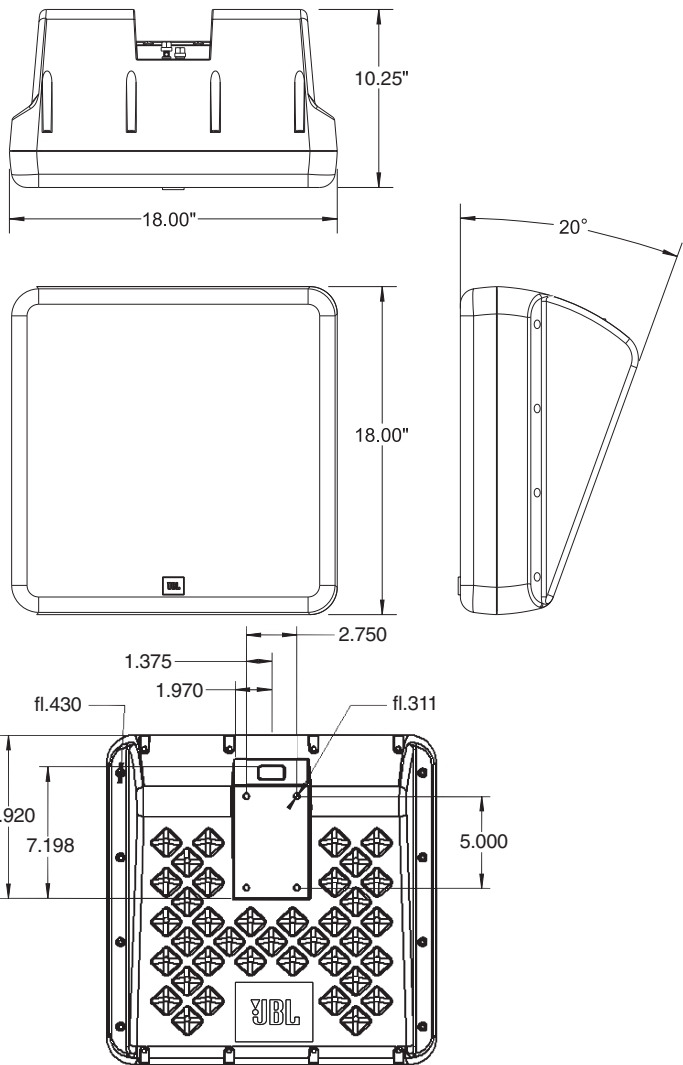
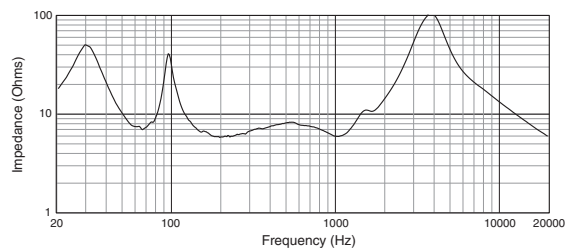

JBL Professional  
8500 Balboa Boulevard, P.O. Box 2200  
Northridge, California 91329 U.S.A.

■ A Harman International Company  
© Copyright 2008 JBL Professional

SS 8350  
CRP 5M  
08/08