

2510 BRACKET



For 2350 & 2390 Series horns & drivers

The JBL Model 2510 bracket is utilized for suspension of JBL 2390-Series (3-inch entrance) and 2350-Series (1½-inch entrance) horns and drivers. The 2510 “sandwiches” between the horn and driver, providing a pickup point. The bracket is constructed of 10-gauge steel and is powder coated black. Multiple pickup points are provided, including a 3.75 inch slot that allows a degree of front/back alignment.

CAUTIONS!!

- 1) This bracket should be used only with hardware approved for rigging applications — The suspension points, hardware and methods that are used to hang the horn and transducer must meet professional rigging standards. Use only load-rated hardware. Never exceed maximum recommended load ratings.
- 2) Inspect Beforehand — Before suspending any horn, transducer and/or loudspeaker always inspect all components (enclosure, threaded fasteners, connecting hardware and lifting hardware) for cracks, deformations, corrosion, and missing or damaged parts that could reduce strength and safety. Building structural supports and hoist motors require inspection by knowledgeable professionals before each use.
- 3) Use Proper Bolt Lengths for Horn/Bracket/Driver Assembly — The bracket adds approximately 0.15" of additional thickness to the Horn/Driver Assembly, Always make sure the bolts are long enough to ensure at least 3 full turns (360° of rotation per turn) of thread engagement. If not, replace the bolts with load-rated bolts of the proper length and threading.

Installation Instructions

- 1) READ THE CAUTIONS, ABOVE.
- 2) Throat Gasket — For use with 2350-Series horns (1½-inch entrance), insert the supplied rubber gasket into the 3-inch throat opening. The throat gasket covers the 3-inch opening to 1½-inches to match the entrance diameter of the 2350-Series horns. The gasket holds itself in place while you install the bracket. For use with 2390-Series horns, omit the gasket.
- 3) Positioning — Position the 2510 between the horn and compression driver, as shown in figure 1. You may position the bracket with the attachment flange facing either toward the horn or toward the driver, depending on your suspension requirements.
- 4) Attaching — For compression drivers with studs, insert the driver studs through the plate, then the horn. Fasten with flatwashers, lockwashers and nuts. For compression drivers that use bolts, insert the bolts with flatwashers and lockwashers through the horn, then the plate and into the driver. Make sure the bolt or stud are long enough to ensure at least 3 full turns of thread engagement (see cautions above). If you used the throat gasket, make sure the gasket positioning did not slip and that it does not stick out into the throat opening.
- 5) Thread Locking Compound — JBL strongly recommends using Loctite 242, Loctite 271, or an equivalent threadlocker on bolts/stud threads to prevent loosening.
- 6) Eye Bolts — A variety of holes are provided for ¼-inch forged steel eye bolts. If eye bolts are used for suspension, load them only in directions shown in Figure 2. The 3¾-inch slot on the attachment flange allows adjustment for time-alignment purposes.
- 7) Tighten — Securely tighten all fasteners. For safety, periodically check the condition of the hardware and tighten all fasteners.

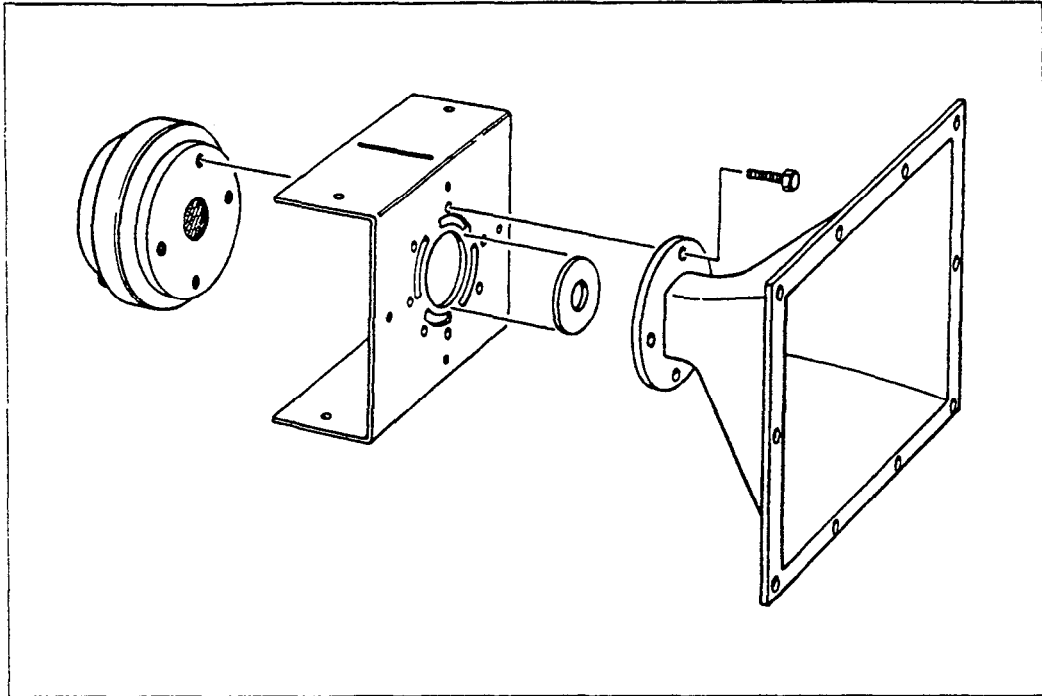

Fig. 1 - 2510 Bracket - Use the gasket for 1 1/2-inch horn/driver, omit for 3-inch horn/driver.

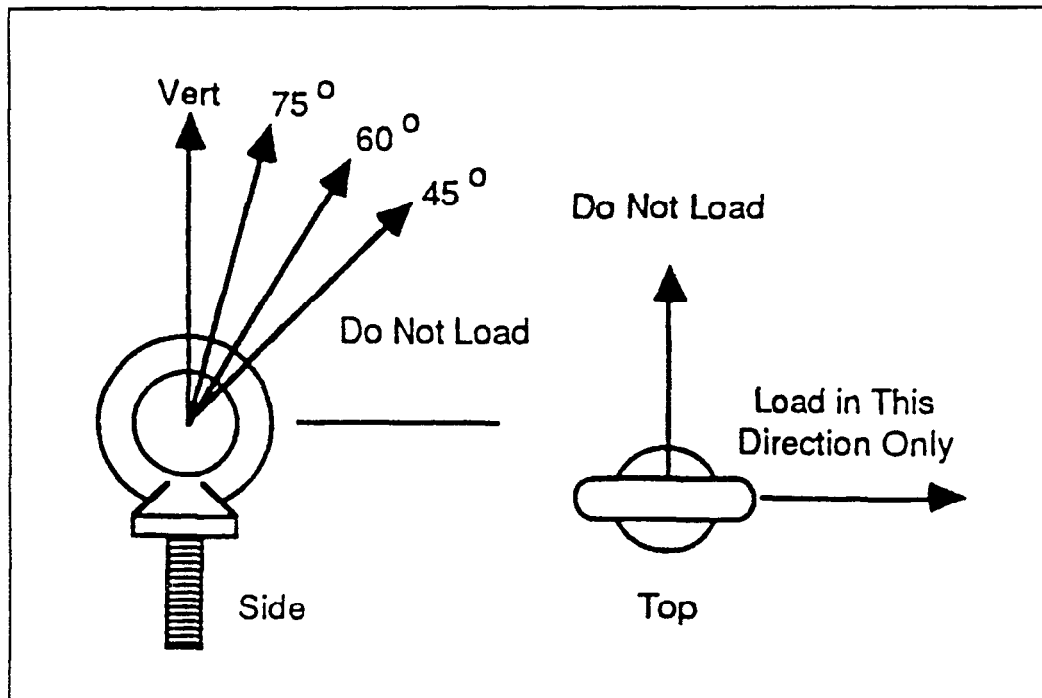

Fig.2