

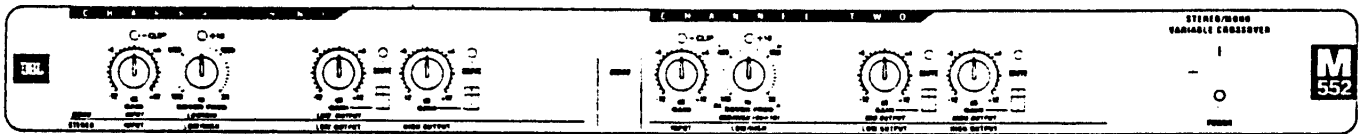

# M552 Variable Crossover

## Owner's Manual



# Safety Precautions

---

## IMPORTANT!

FOR YOUR PROTECTION, PLEASE READ THE FOLLOWING:

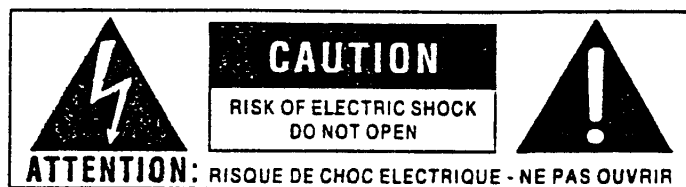

The symbols shown above are internationally accepted symbols that warn of potential hazards with electrical products. The lightning flash with arrowhead symbol within an equilateral triangle warns that there are hazardous voltages and the risk of electric shock within the unit. The exclamation point within an equilateral triangle alerts the user to refer to important information in the user manual.

**THESE SYMBOLS ARE A WARNING THAT THERE ARE NO USER SERVICEABLE PARTS INSIDE THIS EQUIPMENT AND THAT THERE ARE HAZARDOUS VOLTAGES PRESENT.**

**DO NOT OPEN THIS EQUIPMENT YOURSELF. REFER ALL SERVICING TO QUALIFIED PERSONNEL. DO NOT MAKE ANY INTERNAL ADJUSTMENTS OR ADDITIONS TO THIS EQUIPMENT AT ANY TIME. DO NOT TAMPER WITH THE INTERNAL ELECTRONICS.**

**FAILURE TO FOLLOW THESE INSTRUCTIONS MAY CAUSE A SHOCK HAZARD AND MAY VOID WARRANTY SERVICE TO THIS EQUIPMENT.**

This equipment should be operated only at the voltage indicated on the rear panel. Replace the fuse only with the same type and rating as indicated on the top panel.

This equipment must be grounded for correct operation. Do not defeat the safety ground by using a ground lift adapter or by physically removing the ground prong from the plug.

The power cord should be routed so that it cannot be walked upon or pinched by items placed upon or against it. The power cord should be unplugged from the outlet when the equipment is to be unused for a long period of time.

This equipment should be located away from heat sources and should be properly ventilated.

Do not expose this equipment to rain or moisture.

# Table of Contents

---

Safety Precautions .....	2
Introduction .....	4
Product Description .....	4
CD horn pre-emphasis .....	5
Front Panel .....	6
Rear Panel .....	8
Circuit Description .....	9
Block Diagram .....	9
Unpacking and Installation .....	10
Contents of Shipping Container .....	10
Optional Security Cover .....	10
Voltage Selection and Fuse .....	11
Rack Mounting .....	11
Input and Output Connections .....	12
Grounding and Safety .....	13
Operation .....	14
Stereo Mode .....	14
Stereo with LF Sum Output.....	14
Mono Mode .....	15
In Case of Difficulty .....	16
Specifications .....	18
Maintenance and Warranty .....	20
For Qualified Service Personnel Only .....	22

# Introduction

---

## Product Description

The JBL M552 Stereo/Mono Crossover provides precisely adjustable frequency dividing for multi-amplified speaker applications. It has individual level controls for two bands in stereo mode and three bands in mono mode. A selectable, low-frequency summed output is available for a mono sub-woofer connection in stereo applications.

Accurate 24 dB/octave Linkwitz-Riley crossover filters in a state-variable configuration assure a flat frequency response when the outputs are summed acoustically and have the added benefit of coherent phase response of adjacent outputs. The 24 dB/octave slope also protects drivers by rapidly rolling off frequencies beyond the crossover points. Over excursion of low-frequency drivers in vented box enclosures is prevented by 15 Hz high-pass 4th order Butterworth filters. These filters may be by-passed by internal DIP shunts if desired.

No internal rewiring is required to switch between stereo and mono modes - all internal connections are made when a rear panel switch is engaged.

All inputs are RFI filtered, and the outputs are electronically servo-balanced to maintain constant level into balanced or unbalanced loads.

The rear panel contains XLR type input and output jacks and a two terminal barrier strip which allows the audio ground to be separated from the chassis ground. Internal DIP shunts allow output polarity to be reversed. Each output may be muted individually by front panel switches.

Other features include:

- Low frequency range  $\pm 10$  switch.

- $\pm 12$  dB of input and output gain.

- Input clip LEDs on each channel light 3 dB before clipping.

- Toroidal power transformer minimizes AC hum radiation.

- Luminous pointer knobs and yellow and white on black markings aid setup in low light situations.

- Optional Security cover may be fitted to protect control settings.

# CD horn pre-emphasis

---

## Selectable pre-emphasis

The M 552 has optional pre-emphasis for Constant Directivity horns. There are three settings which are selectable via internal DIP shunts:

Bypass	No pre-emphasis
60	pre-emphasis for JBL 60-series horns
80	pre-emphasis for JBL 80-series horns

The 60 series curve has a 6 dB per octave boost to compensate for a CD horn's natural 6 dB per octave rolloff.

The 80 series curve provides additional energy in the 500 Hz to 1000 Hz region since smaller horns cannot maintain constant coverage at these frequencies. This boost provides a smoother frequency response.

The pre-emphasis may be patched to the required band by internal DIP shunts as follows:

Stereo 2-way	High Frequency only
Mono 3-way	Mid Frequency or High Frequency

## Gain characteristic

The gain of the frequency bands is changed when the pre-emphasis is selected.

**OUT** with no pre-emphasis, the sum of all outputs is a constant unity gain

**IN** with pre-emphasis, the Boost/Cut balance provides unity gain at 5 kHz.

The curves vary slightly for each horn series:

60 series	-5 dB at 2 kHz and +6 dB at 20 kHz
80 series	-4 dB at 2 kHz and +6 dB at 20 kHz

The moderate amount of boost provided by the pre-emphasis curves provides a better match for the input levels required by the amplifiers assigned to each frequency band - based upon the following facts:

- 1) When a signal is split into two or more frequency bands, the energy in each band is reduced.
- 2) Most program material contains less energy in the high frequency bands. Energy tends to peak in the 250 Hz band, decreasing by 3 to 6 dB per octave as the frequency increases.
- 3) Compression drivers are inherently more sensitive than cone drivers, and are usually driven by lower powered amplifiers which have less internal gain.

The correct gain control settings should be calculated from the sensitivity of the compression driver, the power amplifier gain and the gain characteristics of each crossover band. The use of a one-third octave Real Time Analyzer is recommended to confirm the gain control settings of each frequency band.

## CAUTION:

**REFER SERVICING OR ADJUSTMENT TO QUALIFIED TECHNICAL PERSONNEL. FURTHER DETAILS MAY BE FOUND IN THE SECTION HEADED 'FOR QUALIFIED TECHNICAL PERSONNEL ONLY'**

# Front Panel

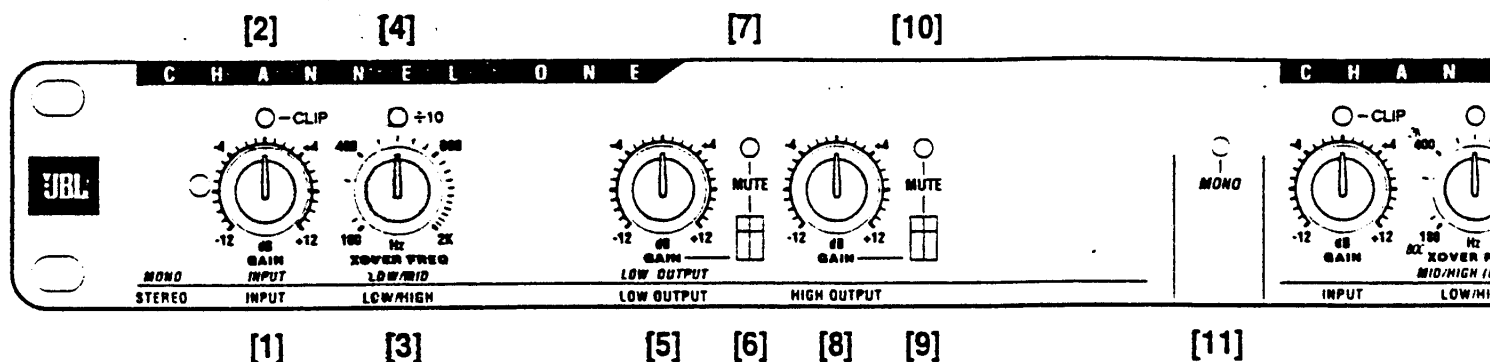

## STEREO MODE

In the **STEREO** mode, the control functions are marked in **WHITE**.

**Channel One and Channel Two functions are identical in the Stereo mode.**

- |             |                           |                                                                         |
|-------------|---------------------------|-------------------------------------------------------------------------|
| [1] + [12]  | <b>INPUT</b>              | Controls the input level with $\pm 12$ dB of gain.                      |
| [2] + [13]  | <b>CLIP LED</b>           | Illuminates 3 dB below clipping.                                        |
| [3] + [14]  | <b>LOW/HIGH</b>           | Sets the crossover point between the LOW and HIGH outputs.              |
| [4] + [15]  | <b>±10 LED</b>            | Indicates that the LOW/HIGH crossover range is 18 to 200 Hz.            |
| [5] + [16]  | <b>LOW OUTPUT</b>         | Controls the LOW Frequency output level with $\pm 12$ dB of gain.       |
| [6] + [17]  | <b>LOW MUTE</b>           | Mutes the LOW Frequency output.                                         |
| [7] + [18]  | <b>MUTE LED</b>           | Indicates that the LOW output is muted.                                 |
| [8] + [19]  | <b>HIGH OUTPUT</b>        | Controls the HIGH Frequency output level with $\pm 12$ dB of gain.      |
| [9] + [20]  | <b>HIGH MUTE</b>          | Mutes the HIGH Frequency output.                                        |
| [10] + [21] | <b>MUTE LED</b>           | Indicates that the HIGH output is muted.                                |
| [22]        | <b>POWER SWITCH + LED</b> | Switches both sides of AC line to give added protection from miswiring. |

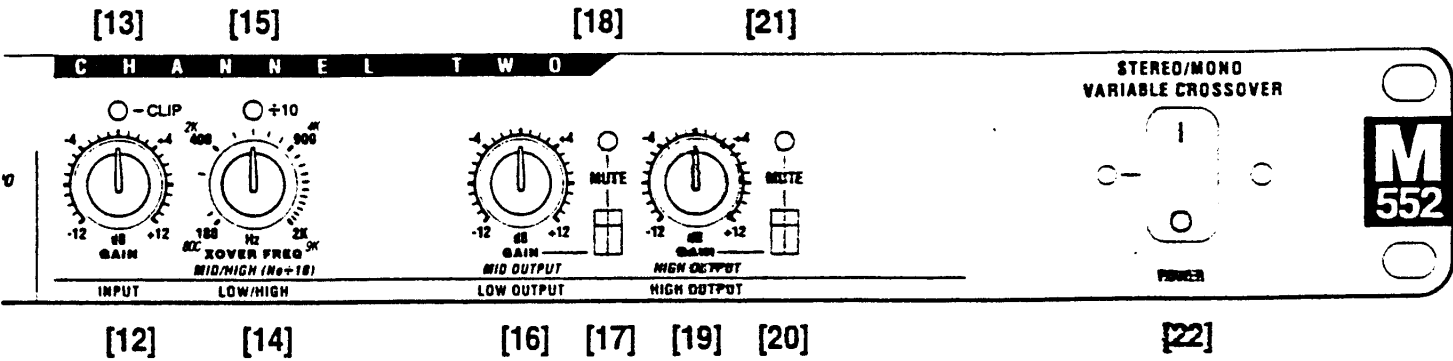

**MONO MODE**

In *MONO* Mode, the control functions are marked in *YELLOW italics* and the *Yellow MONO* LED is lit.

- [1] **INPUT** Controls the input level with ±12 dB of gain.
- [2] **CLIP LED** Illuminates 3 dB below clipping.
- [3] **LOW/MID** Sets the crossover point between the Low and **MID** outputs.
- [4] **±10 LED** Indicates that Low/Mid crossover range is 18 to 200 Hz
- [5] **LOW OUTPUT** Controls the Low Frequency output level with ±12 dB of gain.
- [6] **LOW MUTE** Mutes the Low Frequency output.
- [7] **MUTE LED** Indicates that the Low Frequency output is muted
- [11] **MONO LED** Yellow LED indicates MONO mode
- [14] **MID/HIGH** Sets the crossover point between the Mid and High outputs.
- [16] **MID OUTPUT** Controls the Mid Frequency output level with ±12 dB of gain.
- [17] **MID MUTE** Mutes the Mid Frequency output.
- [18] **MUTE LED** Indicates that the Mid Frequency output is muted.
- [19] **HIGH OUTPUT** Controls the High Frequency output level with ±12 dB of gain.
- [20] **HIGH MUTE** Mutes the High Frequency output.
- [21] **MUTE LED** Indicates that the High Frequency output is muted.

**NOTE:** Channel 2 ±10 LED [15] may illuminate in MONO mode although the crossover frequency is unchanged.

# Rear Panel

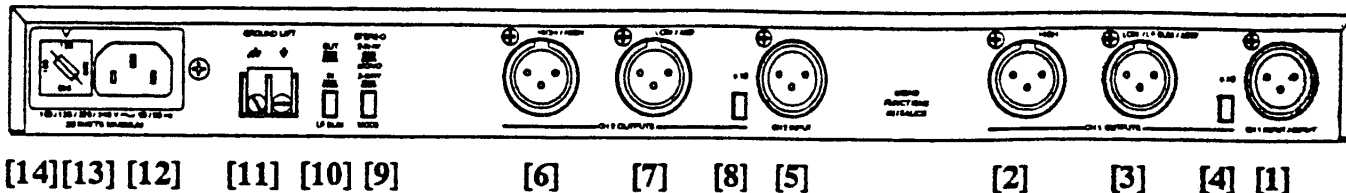

## STEREO MODE

- |                        |                                                                                           |
|------------------------|-------------------------------------------------------------------------------------------|
| [1] INPUT              | XLR electronically balanced input.                                                        |
| [2] HIGH OUTPUT        | XLR electronically servo-balanced output.                                                 |
| [3] LOW OUTPUT         | XLR electronically servo-balanced output.<br>LF Sum output when LF Sum switch is engaged. |
| [4] + 10 SWITCH        | Sets the LOW/HIGH crossover range to 18 to 200 Hz.                                        |
| [5] INPUT              | XLR electronically balanced input.                                                        |
| [6] HIGH OUTPUT        | XLR electronically servo-balanced output.                                                 |
| [7] LOW OUTPUT         | XLR electronically servo-balanced output.                                                 |
| [8] + 10 SWITCH        | Sets the LOW/HIGH crossover range to 18 to 200 Hz.                                        |
| [9] STEREO/MONO SWITCH | Selects: Stereo 2 Way or Mono 3 Way mode.                                                 |
| [10] LF SUM SWITCH     | Sums the stereo channel's Low outputs to mono.<br>DOES NOT FUNCTION IN THE MONO MODE      |

## MONO MODE

- |                 |                                                        |
|-----------------|--------------------------------------------------------|
| [1] INPUT       | XLR electronically balanced input.                     |
| [6] HIGH OUTPUT | XLR electronically servo-balanced output.              |
| [7] MID OUTPUT  | XLR electronically servo-balanced output.              |
| [3] LOW OUTPUT  | XLR electronically servo-balanced output.              |
| [4] + 10 SWITCH | Sets the LOW/MID crossover range to 18 to 200 Hz.      |
| <b>NOTE:</b>    | Channel 2 ÷ 10 Switch [8] is inoperative in Mono mode. |

- |                       |                                                               |
|-----------------------|---------------------------------------------------------------|
| [11] GROUND LIFT      | Barrier Strip allows separation of audio and chassis grounds. |
| [12] AC RECEPTACLE    | Accepts IEC NEMA 515P type cord, included (N. America).       |
| [13] VOLTAGE SELECTOR | Allows operation on 100, 120, 220 or 240 V.                   |
| [14] FUSE             | USE ONLY THE FUSE VALUE INDICATED ON THE TOP PANEL.           |

# Circuit Description

## BLOCK DIAGRAM (Simplified)

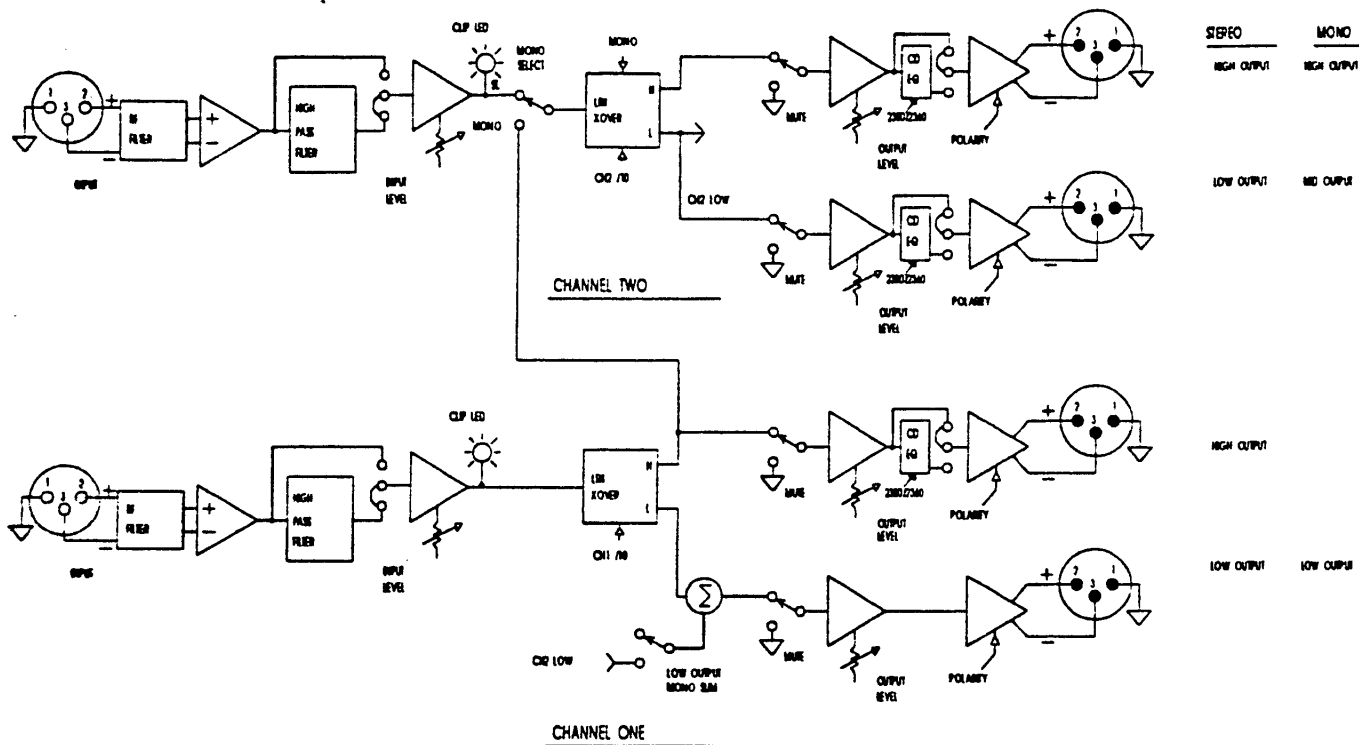

### Stereo Mode:

Channel One and Two crossover functions are identical.

The input signal passes from the XLR connector, through an RFI filter which removes spurious radio frequencies. A differential amplifier removes common mode noise. A 15 Hz, 4th order Butterworth high-pass filter prevents damage due to over-excitation of the cone in vented low-frequency enclosures. An internal DIP shunt allows this filter to be bypassed if desired. The signal then passes through a variable gain stage with  $\pm 12$  dB of gain, controlled by the Input Level control.

The Clip LED monitors the signal level after this gain stage and lights 3 dB below clipping.

The signal then enters the 24 dB/octave crossover stage. The crossover frequency is adjustable and individual rear panel switches allow the crossover frequencies of each channel to be divided by ten.

The low and high frequency signals pass from the outputs of the crossover block to individual mute circuits, then to the output level controls with  $\pm 12$  dB of gain. Internal DIP shunts allow pre-emphasis to be selected for JBL 60-series or 80-series Constant Directivity horns and further DIP shunts allow the polarity of the servo-balanced outputs to be selected before feeding the XLR output connectors.

The Low Frequency outputs of the Channel One and Two crossover blocks may be summed together to supply a Mono Subwoofer output. This summed signal is available at Channel One's Low Frequency output only.

# Unpacking and Installation

---

## **Mono Mode:**

For Mono 3-way applications, a switch on the rear panel replaces the normal input to Channel Two's crossover block with the high frequency output of Channel One's crossover block. Channel Two's Low Frequency Output becomes the Mid-Frequency Output.

Only the Lowest frequency point may be divided by ten.

The LF Sum switch should not be engaged in this mode.

## **Stereo and Mono Modes:**

A rear panel, two terminal barrier strip allows the audio ground to be separated from chassis ground.

All outputs are electronically Servo-Balanced and use differential amplifiers for each phase, connected so that the output of each amplifier also applies 6 dB of negative feedback to the input of the other. Then, if either leg of the output is shorted to ground by an unbalanced load, the feedback is removed from the opposite leg and its level increases by 6 dB thus maintaining constant level to the load.

The 4th order Linkwitz-Riley crossover block is a state variable filter with two desirable properties. Firstly, the outputs of the crossover sum to unity, which results in a flat frequency response with no peaks or dips around the crossover points. Secondly, both outputs are in phase at every frequency. This allows the drivers to be time-offset corrected (time aligned) at all frequencies rather than only at the crossover point.

## **UNPACKING and INSTALLATION**

Thank you for purchasing this JBL crossover.

We encourage you to read and to make use of the material contained in this manual. We welcome your suggestions and comments on our products and on this manual.

Unpack the M552 and carefully inspect it for transportation damage. If any physical damage is discovered, save all of the packaging and immediately contact the dealer or distributor from whom it was purchased.

## **Contents of Shipping Container**

The shipping carton should contain:

The JBL crossover with model number as shown on the shipping container

This instruction manual

A packet containing rack mounting hardware and Spare Fuse for 120 V operation

AC power cord

JBL warranty card

If any items are missing, contact your dealer.

# Voltage Selection and Fuse

---

## CAUTION:

CHECK THE AC LINE VOLTAGE AT YOUR INSTALLATION AND IF NECESSARY SET THE REAR PANEL VOLTAGE SELECTOR TO THE CORRECT VOLTAGE. CONFIRM THAT A FUSE WITH THE CORRECT RATING IS INSTALLED.

## IMPORTANT:

ORIENTATION OF THE FUSE HOLDER DETERMINES THE OPERATING VOLTAGE.

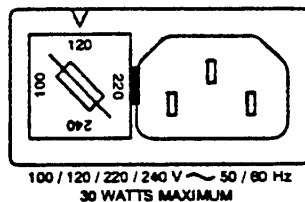

## WARNING: REMOVE THE AC POWER CORD BEFORE REMOVING THE FUSE HOLDER

The M552 can be used with nominal power line voltages of 100, 120, 220 or 240 V, at 50 to 60 Hz. Voltage selection is accomplished by inserting the correct fuse, listed below, into the fuse block and installing the block into the IEC power connector on the back panel. Notice that the end cap on the block can be installed in four different orientations. The operating voltage is set by rotating the cap so that the supply voltage is at the top, with the triangle above, pointing to it. In the illustration above, the cap is oriented for a setting of 120 V. There is a small slot between the right side of the end cap and the line cord socket. The fuse holder is removed by inserting a small flat-bladed screwdriver under the fuse end cap into this slot and gently prying the cap outward.

Fuse Ratings:	[Size: 5 mm x 20 mm]
100 V	250 mA 250 V T type
120 V	200 mA 250 V Slow-blow
220/240 V	125 mA 250 V T type

## RACK MOUNTING

Although internal circuitry susceptible to hum pickup is sufficiently shielded from moderate electromagnetic fields, avoid mounting the unit near large power transformers or motors etc.

Install the M552 in a rack using the provided rack screws. Route the AC cord away from audio lines and plug into a convenient outlet.

## Optional Security Cover

Once the crossover is installed, adjusted, and tested, an optional security cover (JBL model SC8) may be secured to the front panel of the crossover to prevent tampering with the control settings. The cover is secured by two #6 thread cutting screws.

To install *for the first time*:

Insert the screws and turn two turns clockwise, then one turn counterclockwise to eject metal cuttings. Repeat until secure.

# Input and Output Connections

---

## CONNECTOR WIRING

The input and output connectors are XLR - wired pin 2 "hot"

### NOTE:

New 1991 IEC standards for balanced wiring designate XLR Pin 2 as Positive or "Hot" with pin 3 as Negative or "Low".

The M552 conforms to these standards. Other equipment may or may not conform. Check its manufacturer's specifications.

Wire the connectors according to the tables below.

Wiring Guide for XLR Plugs			
Balanced		Unbalanced	
Pin 2	+ / Positive	Pin 2	+ / Positive
Pin 3	- / Negative	Pin 3	Connect to Pin 1
Pin 1	Shield	Pin 1	Shield

### Unbalanced Connection

The unused XLR pin 1, may be connected to shield ground if that is compatible with your grounding scheme.

### Servo-Balanced Outputs

All outputs are electronically Servo-Balanced and maintain a constant output level whether feeding a balanced or an unbalanced load. Without servo-balancing, when one leg of a balanced output is shorted to ground, there is a 6 dB reduction in level. The M552 output circuit uses two differential amplifiers, one for each phase, connected so that the output of each amplifier also applies 6 dB of negative feedback to the input of the other. Then, if either leg of the output is shorted to ground by an unbalanced load, the feedback is removed from the opposite phase and its level increases by 6 dB thus maintaining constant level to the load.

NOTE: Output polarity is reversible by internal DIP shunts.

**REFER SERVICING OR ADJUSTMENT TO QUALIFIED TECHNICAL PERSONNEL. FURTHER DETAILS MAY BE FOUND IN THE SECTION LABELLED "FOR QUALIFIED TECHNICAL PERSONNEL ONLY"**

# Grounding and Safety

---

## GROUNDING

Grounding is a complex subject and is critical to obtaining optimum performance from a sound system. Good grounding practices have three goals:

Safety.

Maintenance of system integrity.

The prevention of oscillation and hum which may be caused by differing potentials within the system, RFI (Radio Frequency Interference) or Electro Magnetic Induction.

## SAFETY

For safe operation, the crossover must be connected to a good mechanical *safety* ground. This provides a current path for any voltage which might appear on the chassis due to an electrical fault in the crossover. Without this path, the unit might be a shock hazard. In addition, a good quality ground on the chassis provides shielding from external fields and minimizes radiation of internal fields to other components.

To comply with safety regulations and to protect our customers, we provide this product with a ground connection through a three-wire power cord. The rear panel barrier strip allows the audio ground to be separated from this chassis ground to eliminate hum caused by ground loops.

The major cause of ground loops is duplicate grounding, which occurs when a component is grounded via its own AC connection and has a second path to ground through a cable shield to another component's chassis ground. These different path lengths may cause a significant potential between the audio ground of the signal source and the mechanical ground to which the crossover has been connected. A voltage is developed, which induces a spurious signal - usually hum - into the signal wiring.

Attention to grounding should eliminate ground loops. See also "In Case of Difficulty".

## "TELESCOPING" SHIELDS

By connecting the shield at one end only, each piece of equipment may be grounded for safety while potential ground loops are avoided. Traditionally, the connection is at the destination, so that any induced signals will flow with the signal and take the most direct path to ground. Should you prefer to lift the shields at the destination and ground them at the source, you must be consistent and follow this convention throughout the system.

## TWIN CONDUCTOR CABLE - Unbalanced Sources

The ~~MS2~~ has differential, balanced input circuits. Balanced wiring is recommended, even with unbalanced sources - especially when running long lines. This takes advantage of the ability of a balanced input to reject signals (such as hum fields) which are induced equally into each of the signal carrying conductors (Common Mode Rejection). Also, twin-conductor, shielded cable is more reliable, since it does not depend on the shield wire itself to complete the signal connection. Stranded shield wires are more vulnerable than the protected internal wires, especially in portable installations. A broken ground connection would result in a loss of audio or a very loud hum. Using twin-conductor cable, a broken shield may only result in a slight increase in noise or hum due to the lack of shielding.

## Long Cable Runs

Longer input cables should be balanced or floating to reduce susceptibility to RFI and hum. If the output of the device feeding the crossover is balanced or floating, simply use a dual-conductor shielded cable. If the source is unbalanced, an isolation transformer may be necessary at the source's output, to supply a balanced signal.

# Operation

---

## BEFORE POWERING UP

Consult your speaker and driver manufacturers' specifications for their recommended crossover frequencies.

Label each power amplifier for its respective frequency band.

Connect each power amplifier's output to its correct speaker or driver.

Set the Stereo/Mono switch.

Connect audio lines to the crossover inputs: to Channels One and Two for stereo operation, or to Channel One only for mono operation.

Connect the appropriate output jacks for either stereo two-way or mono three-way operation.

If the CD Horn pre-emphasis is to be used this must be set by a Qualified Technician - refer to the Section "CD Horn pre-emphasis".

## OPERATION

### NOTE:

Always turn on the crossover before turning on the power amplifiers.

The control knobs will luminesce after being exposed to light.

## STEREO MODE

Use the WHITE markings for stereo operation.

Begin by setting each channel as follows:

Set all gain controls to their center - zero gain position.

Set the LOW/HIGH Crossover frequency

If the desired crossover frequency is below 180 Hz, press in the  $\pm 10$  switch on the rear panel.

Adjust the LOW and HIGH output level controls to the desired output level.

A signal which allows unity gain will provide the best signal to noise ratio.

## STEREO with LF SUM OUTPUT

Connect the M552 as for stereo operation with the following exceptions:

Before applying power to the amplifiers, press in the LF Sum switch on the rear panel

Use only the Channel One Low Output.

---

## MONO MODE

Use the **YELLOW *Italic*** markings for *Mono* mode operation.

Press in the Stereo / Mono switch on the rear panel for Mono 3-way operation. This internally links Channels One and Two together and sets the crossover frequency range for the Mid/High Frequency control to 800 Hz to 9 kHz - indicated by the outer numbers. Proceed as for stereo operation to set crossover frequency and level controls.

### NOTE:

In the Mono mode, the Channel Two, ÷10 function is disabled. If the switch is pushed in, the indicator LED will illuminate but the crossover frequency will be unchanged.

**THE LF SUM SWITCH SHOULD NOT BE ENGAGED IN THE MONO MODE.**

### CAUTION:

**BEFORE PRESSING THE ÷10, LF SUM OR STEREO/MONO SWITCHES, LOWER THE OUTPUTS OF YOUR POWER AMPLIFIERS TO AVOID DAMAGE TO LOUDSPEAKERS.**

# In Case of Difficulty

---

## Symptom: No Sound

### Power Off:

Check that the power indicator LED on the front panel of the crossover is lit. If it is not, confirm that the power switch is on and that the unit is connected to an active AC power source.

Check that the Voltage Selector is set correctly for your AC supply and that a fuse of the correct rating is installed.

### Power On, No Signal Audible:

Confirm that active audio lines are connected to the crossover input(s).

Check that the gain controls are advanced sufficiently.

Check the Mute switches and LED indicators.

Use the Mute switches to selectively mute each output and isolate problems.

## Symptom: Abnormal Audio outputs

Check the Mono/Stereo switch - remember this changes the functions of the gain controls and outputs.

Check the LF Sum switch.

Check the  $\pm 10$  switch - this sets the low frequency crossover range to 18 to 200 Hz or 180 to 2000 Hz.

An internal DIP shunt header may be set incorrectly or may have worked loose in transit. If necessary have this checked by a *Qualified Technician*.

## Symptom: Weak and/or Distorted Audio

Check that a clean signal is being fed to the crossover. It is possible that the unit is reproducing problems originating elsewhere in the audio chain.

Check the Clip LED on each channel. This indicates a level 3 dB below clipping.

Confirm that the input wiring is correct. If only one side of a floating audio line is connected to the input, the resultant audio will be weak and distorted, with a poor frequency response.

---

Check that the input line is not being loaded down by too low an impedance. This can occur if more than one terminating resistor is connected across the line, or if the same line is feeding the inputs of multiple devices without isolation, particularly if the unit feeding the line does not have a low output impedance. Confirm that the output impedance specification of the feeding device and the input impedance specifications of the device(s) connected to it are compatible.

Check by removing other devices.

**Symptom: Hum and/or Buzz**

Check that the grounds of the audio signal path and the chassis and power line of all units in the system are connected according to your system's grounding scheme.

**Hum - Ground loop**

First, separate the grounds by means of the rear panel barrier strip. Audio ground will then be isolated from the chassis and will be referenced to the signal source. The chassis ground will still be connected to mechanical *safety* ground for shock protection.

The use of an isolation transformer in the input signal line may allow the signal to be connected while maintaining ground isolation.

Remember, for safety you must maintain connection to chassis ground. Never lift a *safety* ground.

**Hum - Other Possible Causes:**

Check the audio at an earlier stage in the chain to confirm that the noise is not already in the input signal.

Power amplifiers have large power transformers which handle high currents, and, consequently, have significant magnetic fields surrounding them. Some low level equipment is susceptible to hum being induced from external magnetic fields. As a general rule, low level equipment should not be mounted in close proximity to power amplifiers to avoid induction of this type of hum.

Be certain that all audio wiring except for loudspeaker lines is well shielded, and that low level wiring is not run parallel to and/or in close proximity to AC power wiring, particularly high current and/or lighting lines. If the buzzing changes character or intensity when electrical lighting conditions change, the noise is being induced into the audio from the lighting equipment. It is always advisable to run lighting equipment from its own power source and the audio equipment from a separate source. The services of a qualified electrician may be required to solve such problems.

**Symptom: Intermittent Audio**

Check the other equipment and the wiring to make certain that the signal is not intermittent earlier in the chain and that the connectors are solidly connected to the crossover inputs and outputs.

# Specifications

---

## CONFIGURATIONS

2-Way stereo or 3-Way mono

## FILTERS

**Filter Type:** Linkwitz-Riley, state variable  
**Crossover Slopes:** 24 dB per octave  
**Accuracy:** 14%

## CROSSOVER FREQUENCIES

### Stereo Mode

**Low/High:** 180 Hz to 2 kHz or 18 Hz to 200 Hz (selectable by rear panel switch)

### Mono Mode

**Low/Mid:** 180 Hz to 2 kHz or 18 Hz to 200 Hz  
**Mid/High:** 800 Hz to 9 kHz

## INPUTS

**Type:** Electronically Balanced  
**Connector:** XLR 3 F  
**Polarity:** Pin 2 "hot"  
**RFI Filtering:** Provided on each input  
**Subsonic protection:** 15 Hz high-pass filter: 24 dB/octave Butterworth  
Defeatable via internal DIP shunt \*

**Maximum Input Level**  
**Balanced:** +27 dBa  
**Unbalanced:** +27 dBa

**Input Impedance**  
**Balanced:** 20 k $\Omega$   
**Unbalanced:** 10 k $\Omega$

## OUTPUTS

**Type:** Electronically Servo-Balanced  
**Connector:** XLR 3 M  
**Polarity:** Pin 2 "hot" (reversible internally) \*

**Maximum Output Level**  
**Balanced:** +27 dBu  
**Unbalanced:** +22 dBu

**Output Impedance**  
**Balanced:** 102  $\Omega$   
**Unbalanced:** 51  $\Omega$

**10 k $\Omega$  Load**      **600  $\Omega$  Load**  
**+25 dBm**  
**+20 dBm**

---

## PERFORMANCE

<b>THD + Noise:</b>	<0.004% [crossover @ 1 kHz, 30 kHz filter]	
<b>Dynamic Range (Balanced Output)</b>		
<b>Minimum:</b>	>115 dB	
<b>Typical:</b>	>117 dB	
<b>Hum &amp; Noise: (Maximum)</b>		
	<b>Stereo Mode</b>	<b>Mono Mode</b>
<b>Low Frequency output:</b>	<-90 dBu	<-90 dBu
<b>Mid Frequency output:</b>		<-89 dBu
<b>High Frequency output:</b>	<-89 dBu	<-88 dBu
<b>Frequency Response</b>		
<b>High-pass Filter OUT:</b>	10 Hz (-0.5 dB) to 75 kHz (-3 dB)	
<b>15 Hz High-pass Filter IN:</b>	15 Hz (-3 dB) to 75 kHz (-3 dB)	

## CD HORN PRE-EMPHASIS

<b>Internal DIP shunt selects:</b>	<b>Bypass : 60 : 80 *</b>
<b>Bypass:</b>	No pre-emphasis [Factory setting]
<b>60:</b>	Pre-emphasis for JBL 60-series horns
<b>80:</b>	Pre-emphasis for JBL 80-series horns
<b>Gain characteristic</b>	
<b>OUT:</b>	Summed output shows unity gain at all frequencies
<b>IN:</b>	With pre-emphasis in, Boost/Cut balance gives unity gain at 5 kHz
<b>60 series:</b>	-5 dB at 2 kHz and +6 dB at 20 kHz
<b>80 series:</b>	-4 dB at 2 kHz and +6 dB at 20 kHz
<b>Pre-emphasis patch points:</b>	via internal DIP shunts *
<b>Mono 2-Way:</b>	High Frequency band only
<b>Stereo 3-Way:</b>	Mid Frequency or High Frequency band

\* **CAUTION: REFER ALL SERVICING OR INTERNAL ADJUSTMENT TO QUALIFIED SERVICE PERSONNEL**

## AC POWER

<b>AC PROTECTION</b>	Fuse in AC receptacle (fuse size 5 mm x 20 mm)
<b>100 V:</b>	250 mA 250 V T type
<b>120 V:</b>	200 mA 250 V Slow-blow
<b>220 / 240 V:</b>	125 mA 250 V T type
<b>OPERATING RANGE</b>	
<b>@ 120 V setting:</b>	117 V $\pm$ 11% (104 V - 130 V)

## PHYSICAL

<b>Dimensions:</b>	19" EIA Rack Mounting 1.75" high (45 mm) by 5.67" (145mm) deep
<b>Net Weight:</b>	5.8 lbs (2.6 Kg)
<b>Shipping Weight:</b>	7.4 lbs (3.4 Kg)

## SAFETY

Designed to comply with UL and CSA Standards

# Maintenance and Warranty

---

## CAUTION

**THE FULL AC LINE VOLTAGE AS WELL AS HIGH VOLTAGE/HIGH CURRENT DC ARE PRESENT AT SEVERAL POINTS INSIDE THE CHASSIS. TO REDUCE THE RISK OF ELECTRIC SHOCK, DO NOT PERFORM ANY SERVICING OTHER THAN THAT CONTAINED IN THE OPERATING INSTRUCTIONS UNLESS YOU ARE QUALIFIED TO DO SO. REFER ALL SERVICING TO QUALIFIED SERVICE PERSONNEL.**

## MAINTENANCE

This JBL product is all solid state, ruggedly constructed and uses the finest components. As such it will provide years of trouble free use with normal care. All parts are conservatively rated for their application. *No special preventive maintenance is required.*

The metal and plastic surfaces of the unit may be cleaned with a damp cloth. In case of heavy dirt, a non-abrasive household cleaner such as Formula 409<sup>®</sup> or Fantastik<sup>®</sup> may be used. Do not spray the cleaner directly onto the front of the unit, as it may destroy the lubricants in the switches and controls! Spray cleaner onto a cloth and then use the cloth to clean the unit.

**THERE ARE NO USER SERVICEABLE PARTS INSIDE.**

**REFER ALL SERVICING TO QUALIFIED SERVICE PERSONNEL.**

## WARRANTY

This product is warranted by the manufacturer to the original USA purchaser against defects in material and workmanship for a period of two years from the date of purchase. Complete terms of the USA Limited Warranty are stated on the warranty card packed with this manual. If this product was purchased in another country, contact your JBL dealer or distributor for information on the terms of the warranty applicable in your country. We require that you retain a copy of your dated sales receipt for proof of warranty status.

### **USA purchasers only:**

If your JBL product ever needs service, please write or telephone:

JBL Incorporated (Attn: Customer Service Department),  
8500 Balboa Boulevard, P.O. Box 2200,  
Northridge, CA 91329  
(818 893-8411).

JBL may direct you to an authorized JBL Service Agency, or ask you to return your unit to the factory for repair. In either case, you will need to present the original bill of sale to establish the date of purchase. **DO NOT** ship your JBL product to the factory without prior authorization.

All products shipped to the factory must be accompanied by a Return Authorization (R.A.) Number and must be shipped prepaid. COD shipments will not be accepted.

Field repairs are not normally authorized during the warranty period, and repair attempts by unqualified personnel may invalidate the warranty.

Customers outside the USA should contact their local JBL Professional Products dealer or distributor for warranty assistance. Do not return products to the factory unless you have been given specific instructions to do so.

# Notes

---

# For Qualified Service Personnel Only

---

## CAUTION

THESE SERVICING INSTRUCTIONS ARE FOR USE BY QUALIFIED PERSONNEL ONLY.

TO REDUCE THE RISK OF ELECTRIC SHOCK, DO NOT PERFORM ANY SERVICING OTHER THAN THAT CONTAINED IN THE OPERATING INSTRUCTIONS UNLESS YOU ARE QUALIFIED TO DO SO. REFER ALL SERVICING TO QUALIFIED SERVICE PERSONNEL.

### Constant Directivity Horn EQ Assignment:

CD Horn EQ can be assigned to only one output of each channel at a time.

All other settings must be in bypass.

### CD Pre-emphasis Header Settings

	STEREO		MONO
	Ch.1	Ch. 2	
High	9	12	12
Mid	N.A.	N.A.	11

### CD Horn EQ type:

2380 series:	H6	H8	In
2360 series:	H6	H8	Out

### High Pass Filter (15Hz) IN:

Channel 1	H17
Channel 2	H18

### Output Polarity:

<b>Stereo:</b>				<b>Mono:</b>	
Channel 1:	High	SW5		<b>High</b>	SW12
	Low	SW3		<b>Mid</b>	SW10
Channel 2:	High	SW12		<b>Low</b>	SW3
	Low	SW10			

## DIP Shunt Locations:

The following drawing is also printed inside the top panel of the M552.

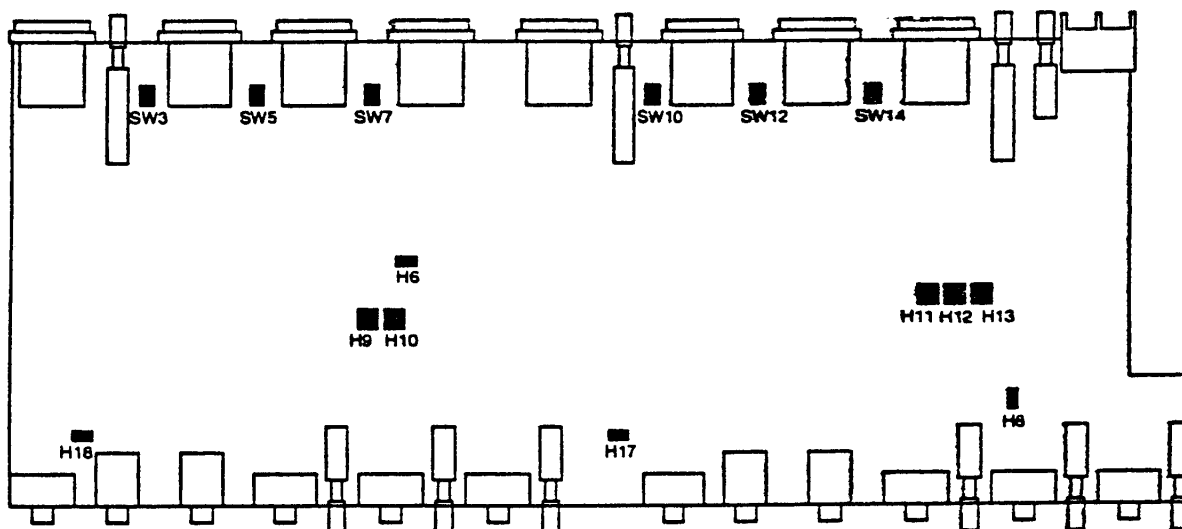

### CD HORN EQ ASSIGNMENT

CD EQ can be assigned to only one output on each channel at a time. All others must be bypassed.

M553: H13: CH2 High/Mono High  
 H12: CH2 Mid/Mono High Mid  
 H10: CH1 High  
 H9: CH1 Mid

M552: H12: CH2 High/Mono High  
 H11: Mono Mid  
 H9: CH1 High



BYPASS



ACTIVE

### HIGH PASS FILTER

H17: CH2  
 H18: CH1



OUT



IN

### OUTPUT POLARITY

M553: SW14: CH2 High/Mono High  
 SW12: CH2 Mid/Mono High Mid  
 SW10: CH2 Low  
 SW7: CH1 High  
 SW5: CH1 Mid/Mono Low Mid

M552: SW12: CH2 High/Mono High  
 SW10: CH2 Low/Mono Mid  
 SW5: CH1 High  
 SW3: CH1 Low/Mono Low



NORMAL



REVERSE

### CD HORN EQ TYPE

H6, H8 Select 2380 Series Horn EQ when shunt jumper is installed. 2360 Series Horn EQ is selected when jumpers are not installed.

38-0086-A



JBL Incorporated  
8500 Balboa Blvd.  
Northridge, California 91329 USA

**H** A Harman International Company

Part No. 18-0411-A  
(North America)