

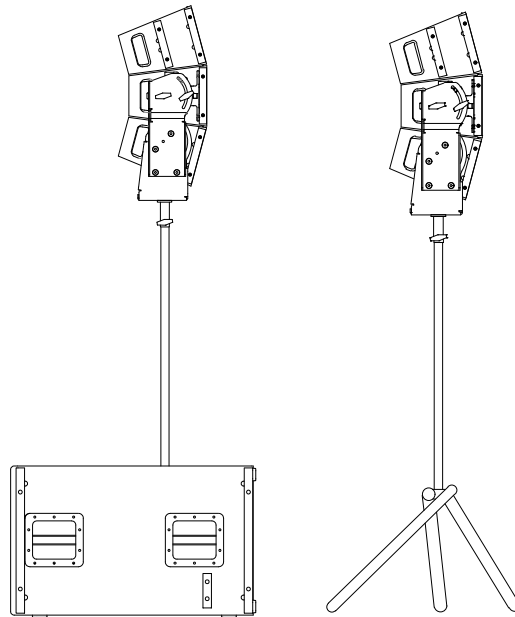

VT4886-UB UNIVERSAL BRACKET
FOR VERTEC SUBCOMPACT SYSTEMS
USER GUIDE



IMPORTANT SAFETY INSTRUCTIONS

1. Read these instructions.
2. Keep these instructions.
3. Heed all warnings.
4. Follow all instructions.
5. Do not use this apparatus near water.
6. Clean only with a dry cloth.
7. Do not block any ventilation openings. Install in accordance with manufacturer's instructions.
8. Do not install near any heat sources such as radiators, heat registers, stoves, or other apparatus that produce heat.
9. Only use attachments / accessories specified by the manufacturer.
10. Use only with a cart, stand, tripod, bracket, or table specified by the manufacturer or sold with the apparatus. When a cart is used, use caution when moving the cart / apparatus combination to avoid injury from tip-over.
11. Refer all servicing to qualified service personnel. Servicing is required when the apparatus has been damaged in any way, such as liquid has been spilled or objects have fallen into the apparatus, the apparatus has been exposed to rain or moisture, does not operate normally, or has been dropped.
12. Do not expose this apparatus to rain or moisture.
13. Hearing damage, prolonged exposure to excessive SPL: the loudspeaker is easily capable of generating sound pressure levels (SPL) sufficient to cause permanent hearing damage to performers, production crew and audience members. Caution should be taken to avoid prolonged exposure to SPL in excess of 90 dB.

PRECAUTIONS

The VerTec series speakers covered by this manual are not intended for use in high moisture environments. Moisture can damage the speaker cone and surround and cause corrosion of electrical contacts and metal parts. Avoid exposing the speakers to direct moisture. Keep speakers out of extended or intense direct sunlight. The driver suspension will prematurely dry out and finished surfaces may be degraded by long-term exposure to intense ultra-violet (UV).

Vertec Subcompact Series speakers can generate considerable energy. When placed on a slippery surface such as polished wood or linoleum, the speaker may move due to its acoustical energy output. Precautions should be taken to assure that the speaker does not fall off a stage or surface on which it is placed.

STAND MOUNTING SAFETY PRECAUTIONS

The VT4886-UB includes a pole mount adapter to allow mounting on tripod stands or on an extension rod (pole) over subwoofers. When using stands or poles, be sure to observe the following precautions:

- Check the stand or pole specification to be certain the device is designed to support the weight of the speaker. Observe all safety precautions specified by the manufacturer.
- Always verify that the stand (or subwoofer/pole) is placed on a flat, level and stable surface and be sure to fully extend the legs of tripod type stands. Position the stand so that the legs do not present a trip hazard.
- Route cables so that performers, production crew, and audience will not trip and topple the speakers.
- Inspect the stand (or pole and associated hardware) before each use and do not use equipment with worn, damaged, or missing parts.
- Do not attempt to place more than three VT4886 loudspeakers on a stand or pole.

- When mounting VT4886 loudspeakers on a pole or tripod, integral suspension hardware must be used to secure the speakers to each other. Only the correct quick release pins and hardware supplied by JBL are to be used.
- Always be cautious when deploying the system outdoors. Unexpected winds may topple a system. It may be necessary to place additional weight (e.g., sandbags) on the base of the stand to improve stability. Avoid attaching banners or similar items to any part of a speaker system. Such attachments could act as a sail and topple the system.
- Unless you are confident that you can handle the weight of the speaker, ask another person to help you get it onto the tripod stand or pole.
- Using the VT4886-UB, up to three VT4886 cabinets may be mounted on a JBL SS2-BK tripod stand or with the SS4-BK or SS5-BK adjustable pole mount or extension rod to their companion VT4883 subwoofers.

SUSPENSION OF LOUDSPEAKER SYSTEM

Before attempting to suspend your JBL loudspeakers, read and understand the following safety information.

IMPORTANT SAFETY WARNING!

The information in this section has been assembled from recognized engineering data and is intended for informational purposes only. None of the information in this section should be used without first obtaining competent advice with respect to applicability to a given circumstance. None of the information presented herein is intended as a representation or warranty on the part of JBL. Anyone making use of this information assumes all liability arising from such use.

All information presented herein is based upon materials and practices common to North America and may not directly apply to other countries because of differing material dimensions, specifications, and/or local regulations. Users in other countries should consult with appropriate engineering and regulatory authorities for specific guidelines.

Correct use of all included hardware is required for secure system suspension. Careful calculations should always be performed to ensure that all components are used within their working load limits before the array is suspended. Never exceed the maximum recommended load ratings.

Before suspending any speaker system always inspect all components (enclosure, rigging frames, pins, eyebolts, track fittings, etc.) for cracks, deformations, corrosion, missing, loose or damaged parts that could reduce strength and safety of the array. Do not suspend the speaker until the proper corrective action has been taken. Use only load-rated hardware when suspending JBL suspendable loudspeaker models.

ARE YOU NEW TO RIGGING?

If you are new to rigging, you should do the following:

- Read and study JBL Technical Note Volume 1, Number 14: Basic Principles for Suspending Loudspeaker Systems (available at http://www.jblpro.com/pub/technote/tn_v1n14.pdf)
- Know the rules for safe rigging.
- Attend a safe rigging seminar, such as that presented by professionals like Rigging Seminars™ (www.riggingseminars.com) or by Chain Motor Hoist manufacturers like Columbus McKinnon Corp. (manufacturers of the C/M Lodestar).
- Meet and establish a relationship with a licensed mechanical or structural engineer. Get in the habit of asking them questions instead of guessing about their answers. Learn from what they tell you.
- Meet and discuss this aspect of your business with your Insurance Agent.
- Research and understand the codes, practices, and requirements in the venues where you intend to operate your sound system.

GENERAL HARDWARE INFORMATION

Any hardware used in an overhead suspension application must be load rated for the intended use. Generally, this type of hardware is available from rigging supply houses; industrial supply catalogs and specialized rigging distributors. Local hardware stores do not usually stock these products. Hardware that is intended for overhead suspension will comply with ASME B30.20 and will be manufactured under product traceability controls. Compliant hardware will be referenced with a working load limit (WLL) and a traceability code.

ATTACHMENT TO STRUCTURES

A licensed Professional Engineer must approve the placement and method of attachment to the structure prior to the installation of any overhead object. The following performance standards should be provided to the Professional Engineer for design purposes; Uniform Building Code as applicable, Municipal Building Code as applicable, and Seismic Code as applicable.

The installation of the hardware and method of attachment must be carried out in the manner specified by the Professional Engineer. Improper installation may result in damage, injury or death.

INSPECTION & MAINTENANCE

Suspension systems are comprised of mechanical devices and, as such, they require regular inspection and routine maintenance to ensure proper function ability. Before suspending or pole mounting any speaker system always inspect all components (enclosure, suspension frames or brackets, pins, eyebolts, etc.) for cracks, deformations, corrosion, missing, loose or damaged parts that could reduce strength and safety of the array. Do not suspend or pole mount the speaker until the proper corrective action has been taken.

Installed systems should be inspected at least annually. The inspection shall include a visual survey of all corners and load bearing surfaces for signs of cracking, water damage, de-lamination, or any other condition that may decrease the strength of the loudspeaker enclosure.

Accessory suspension hardware provided with or for JBL VT4886 and VT4883 loudspeakers must be inspected for fatigue at least annually or as required by local ordinance. The inspection shall include a visual survey of the material for signs of corrosion, bending or any other condition that may decrease the strength of the fastener. Additionally, any eyebolts shall be checked for possible spin-out of the enclosure.

For all other hardware and fittings, refer to the hardware manufacturer's inspection and maintenance guidelines for process.

JBL is not responsible for the application of its products for any purpose or the misuse of this information for any purpose. Furthermore, JBL is not responsible for the abuse of its products caused by avoiding compliance with inspection and maintenance procedures or any other abuse.

Prior to suspending the system, an expert, trained and experienced in suspending speaker systems should inspect all parts and components.

RESOURCES

Adaptive Technologies Group
562.424.1100
1635 E. Burnett Street
Signal Hill, CA 90755
www.adapttechgroup.com

McMaster Carr
Various Locations in the USA
For a location near you, visit
them at www.mcmaster.com

JBL Professional - Tech Note Vol. 1 No. 14
"Basic Principles for Suspending Loudspeakers"
www.jblpro.com/catalog/support/getfile.aspx?docid=296&doctype=3

SAFE SUSPENSION

JBL suspendable version loudspeakers are supplied with built-in internal brackets. The systems are designed to facilitate the suspension of the loudspeaker by a qualified person familiar with rigging hardware and industry practices. Improper installation may result in damage, injury or death. If you are unfamiliar with Safe Rigging Practices you will need to consult with a qualified person familiar with rigging hardware and industry practices.

WORKING LOAD LIMIT (WLL)

VT4886-UB WLL = 136 lbs (62 kg)

MAXIMUM CONFIGURATIONS:

Tripod- or Pole-Mounted:	3x VT4886
Stacked (with stabilizer legs):	4x VT4886
Suspended (Underbalcony):	4x VT4886
Wall-Mounted:	3x VT4886

Working Load Limit for M10 Suspension Points

The working load limit (WLL) of any JBL suspendable loudspeaker system using the M10 attachment point will be maintained as long as no more than 470lbs/213kg from 2 points equally loaded or no more than 235lbs./ 106 kg from a single point maximum and as long as safe rigging practices are followed.

For permanent installation applications utilizing the M10 suspension points order JBL 229-00009-01. This kit includes three (3) M10 x 35 mm forged shoulder steel eyebolts with washers.

WARNING

Suspension of JBL loudspeakers must employ a minimum of two (2) attachment points. When "bridling" a JBL loudspeaker system, two (2) legs of equal length must be used. The rear attachment points are pull-back points and are intended only for use in adjusting the down-angle of the speaker enclosure. Only the top and bottom attachment points are intended for use as suspension points.

Hearing Damage, Prolonged Exposure To Excessive SPL

VerTec series loudspeakers are easily capable of generating sound pressure levels (SPL) sufficient to cause permanent hearing damage to performers, production crew and audience members. Caution should be taken to avoid prolonged exposure to SPL in excess of 90 dB.

JBL VT4886-UB UNIVERSAL BRACKET CONTENTS

ITEM	QTY	PART NUMBER	DESCRIPTION
1	1	444871-001	BRACKET BASE, 10GA STEEL
2	1	444872-001	SIDE EXTENSION PLATE
3	1	444872-002	SIDE EXTENSION PLATE
4	12	444874-001	THUMB NUT, #1/4-20
5	12	N/A	LOCK WASHER, #1/4, CLZ
6	2	444870-001	SPEAKER ATTACHMENT ADAPTER PLATE
7	5	444873-001	CLAMP HANDLE, #1/4-20
8	8	444875-001	BALL LOCK PIN, 0.25 X 1.25
9	1	444876-001	POLE MOUNT ADAPTER
10	2	818-85710-06	BOLT, M10 X 16MM, BLACK
11	2	846-74110-02	LOCK WASHER, M10
12	2	444913-001	STABILIZER LEG
13	4	444914-001	RUBBER FOOT, 0.75 DIA X 0.5H
14	8	803-41010-10	#8-32 X 5/8, PAN, BLK
15	4	832-30010-00	#8-32 K-LOCK NUT, BLK
16	4	806-73010-32	#1/4-20 X 2", ALLEN, BLK
17	4	834-36010-00	#1/4-20 X 2", NYLOC NUT, BLK

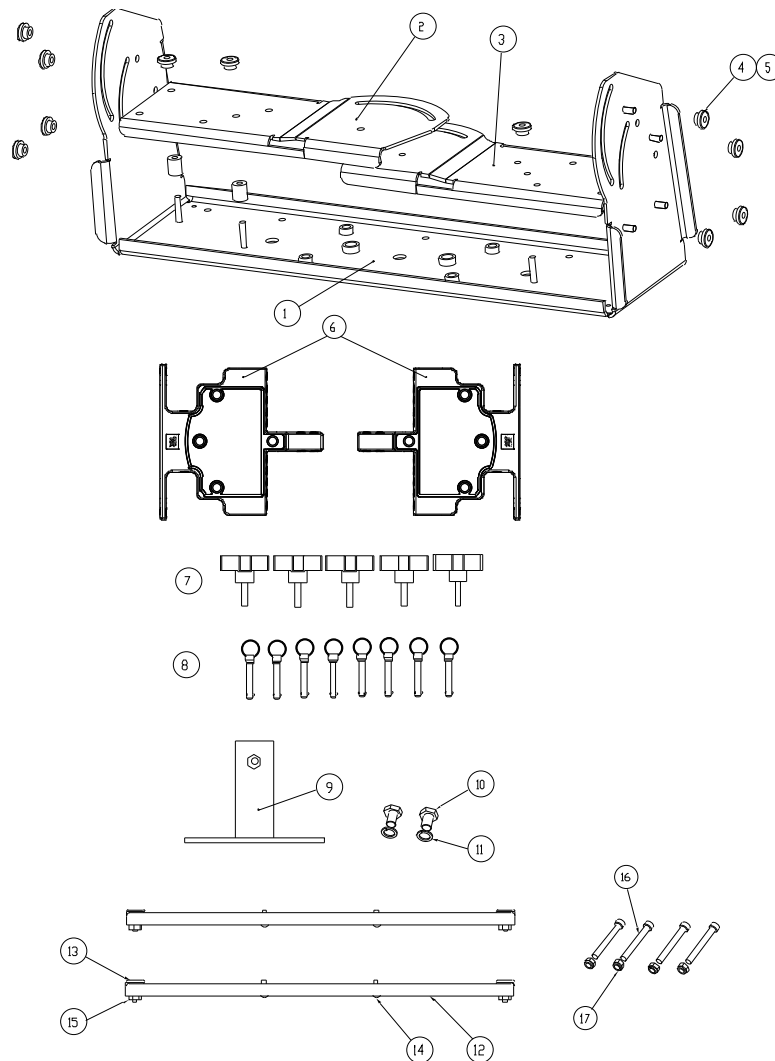

Figure 1: VT4886-UB UNIVERSAL BRACKET PACKAGE CONTENTS

DESCRIPTION:

The VT4886-UB Universal Bracket is suitable for the following applications:

POLE MOUNT MODE:

- Can be used with supplied pole mount adapter for 1, 2 or 3x VT4886 enclosures
- Flexible attachment options:
 - Multiple pivot points and removable side extension plates provide a wide range of attachment options and tilt angle adjustment
 - M10 threaded inserts for attachment of supplied pole mount adapter
 - Pole mount adapter compatible with optional JBL SS4-BK or SS5-BK hand crank extension rod for mounting up to 3x VT4886 on VT4883 subwoofer
 - Pole mount adapter compatible with JBL SS2-BK (optional) and other 3rd party tripod stands

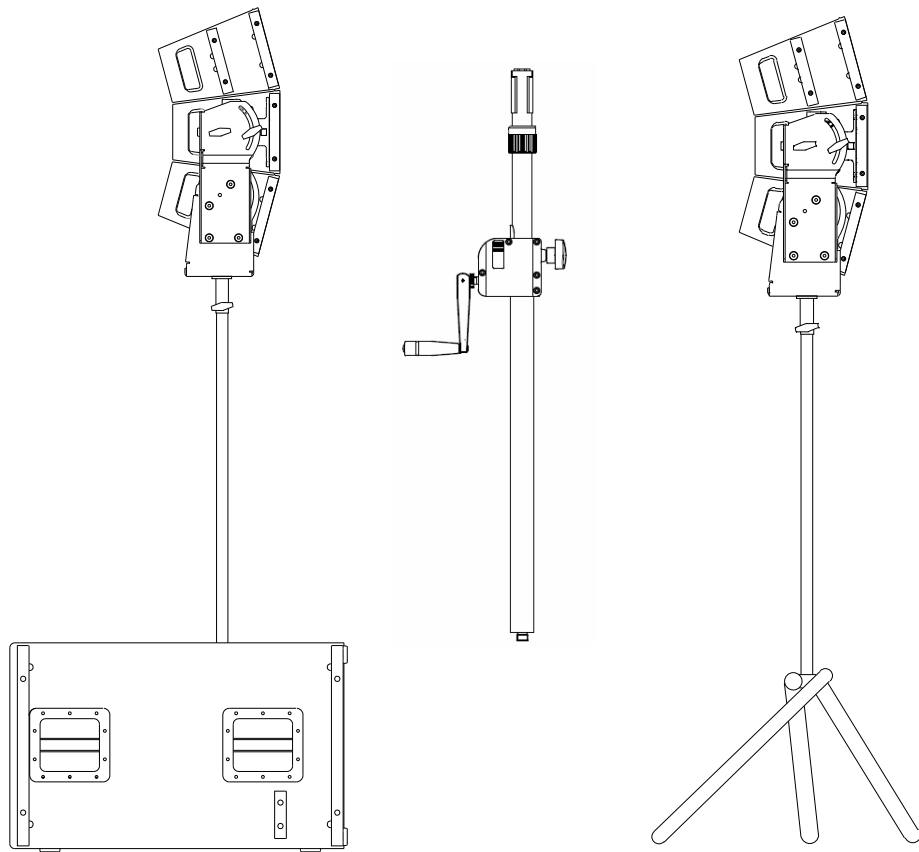

Top-to-bottom:
3x VT4886
VT4886-UB
JBL SS4-BK
VT4883

JBL SS5-BK

Top-to-bottom:
3x VT4886
VT4886-UB
JBL SS2-BK

Figure 2: Side view of three VT4886 enclosures mounted on VT4883 using optional JBL SS4-BK pole; optional JBL SS5-BK hand crank height-adjustable pole with vibration-free mount; side view of tripod-mounted system with optional JBL SS2-BK stand

STACKED MODE: DISTRIBUTED FRONT FILL, FRONT-OF-HOUSE, SIDE FILL

- Can be used as a cradle for 1, 2, 3 or 4x VT4886 enclosures for distributed front fill
- Assembly can also be secured to subwoofers for stacked FOH or side fill applications
- Flexible attachment options:
 - Multiple pivot points and removable side extension plates provide a wide range of attachment options and tilt angle adjustment
 - Removable stabilizer legs provide improved stability for downwards or upwards orientation

Low profile mount position
(-12 degrees max downtilt)

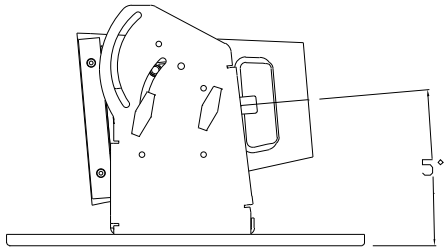

Upper mount position – base only
(-35 deg maximum downtilt)

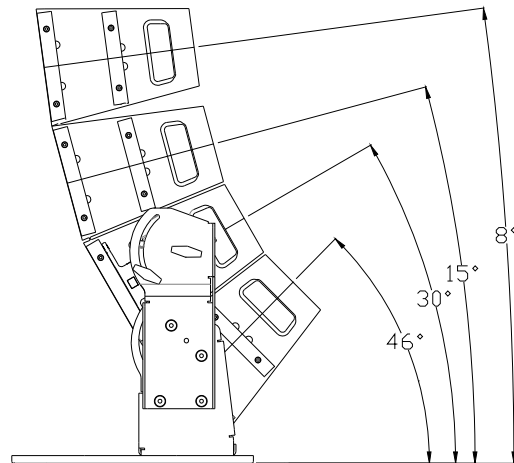
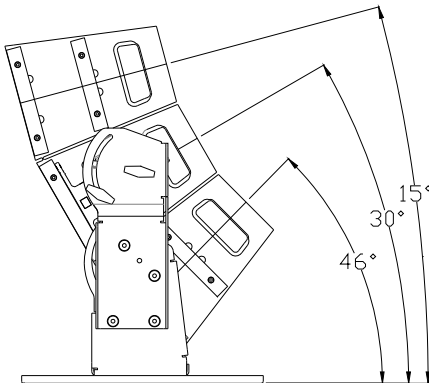
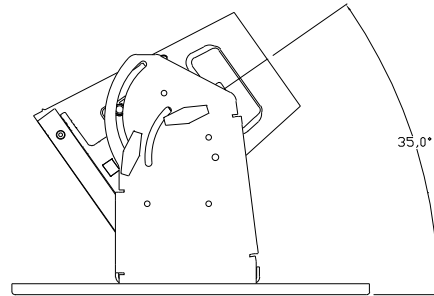

Figure 3: Side view of stacked front fill systems using VT4886-UB in yoke mode with supplied stabilizer legs. For larger arrays, shift stabilizer legs forwards to keep center of gravity centered on the stabilizer leg footprint.

STACKED MODE: STAGE MONITOR, DRUM FILL OR DJ MONITOR

- Can be used as a cradle for 1, 2, 3 or 4x VT4886 enclosures for stage monitoring
- Assembly can also be secured to subwoofers for drum fill or DJ monitoring
- Flexible attachment options:
 - Multiple pivot points and removable side extension plates provide a wide range of attachment options and tilt angle adjustment
 - Removable stabilizer legs provide improved stability for downwards or upwards orientation

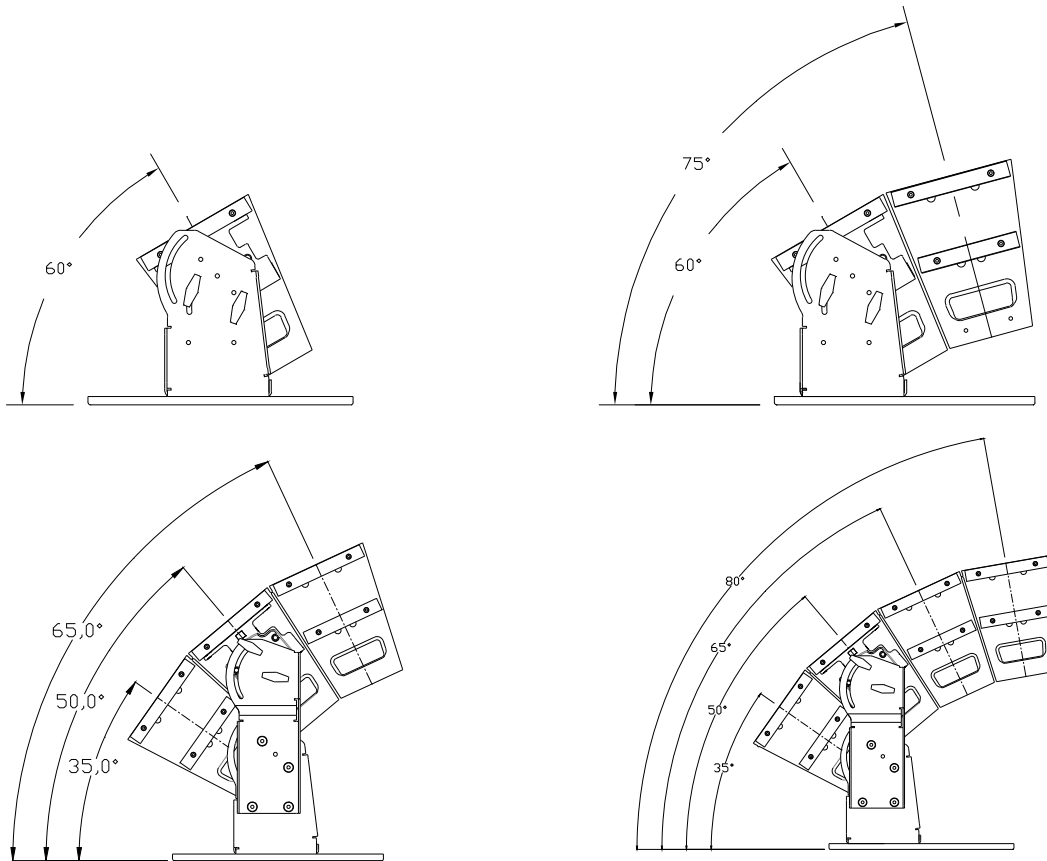

Figure 4: Side view of 1x, 2x, 3x, 4x VT4886 stacked systems using VT4886-UB in yoke mode with supplied stabilizer legs. For larger arrays, shift stabilizer legs backwards to keep center of gravity centered on the stabilizer leg footprint.

UNDER-BALCONY (SUSPENDED) MODE:

- Can be inverted for suspension of 1, 2, 3 or 4x VT4886 enclosures
- Flexible attachment options:
 - Multiple pivot points and removable side extension plates provide a wide range of attachment options and tilt angle adjustment
 - Central 0.53" (13.5 mm) diameter hole for attachment of drop down extension rod (not supplied) for pipe mounting using additional 3rd party accessories
 - Two 0.53" (13.5 mm) diameter holes available for eyebolt attachment
 - Ten mount holes (0.277" / 7.04 mm diameter) available on Universal Bracket base for permanent installation (see Figures 16 and 18 for details).

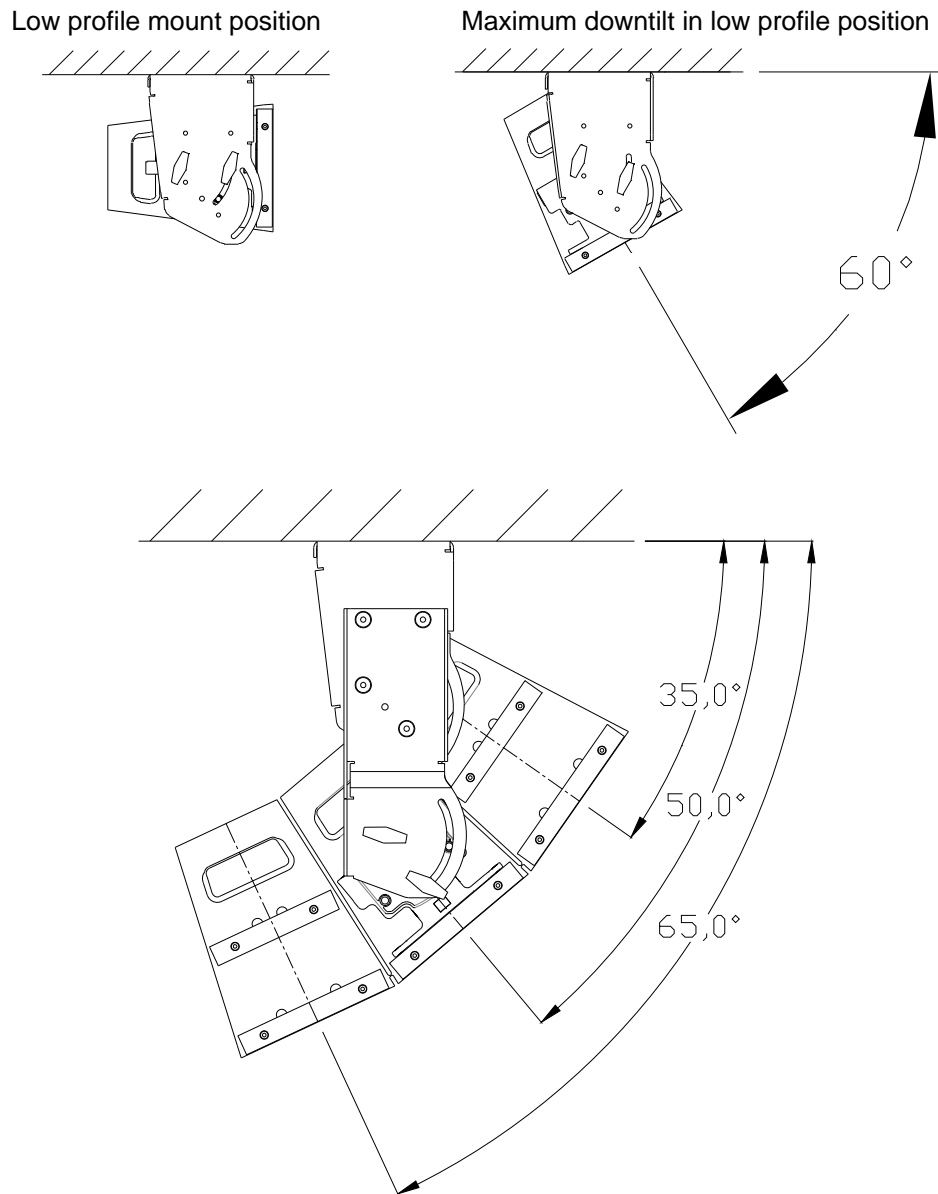

Figure 5: VT4886-UB under-balcony examples

OMNIMOUNT MODE

- Standard Omnimount bolt hole pattern with 4x 3/8 in x 16 threaded inserts available on Universal Bracket base
- For use with Omnimount 120.0 series accessories for up to 3x VT4886 enclosures
- For use with Omnimount 240.0 series accessories for up to 4x VT4886 enclosures
- Consult www.omnimountpro.com for detailed accessory specifications and guidelines

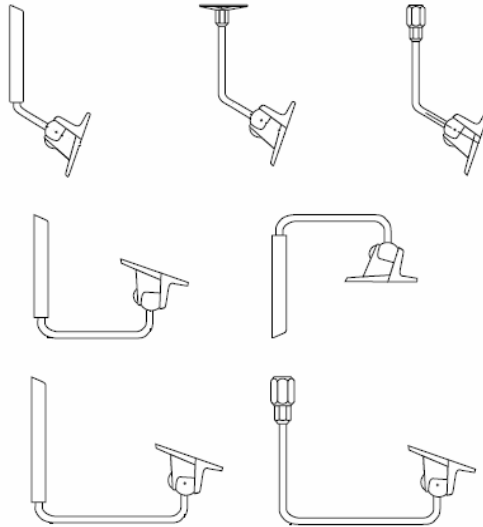

Figure 6: Optional Omnimount accessories, compatible with VT4886-UB

WALL-MOUNT MODE

- Can be used horizontally for wall mounting 1, 2 or 3x VT4886
- Flexible attachment options:
 - Multiple pivot points and removable side extension plates provide a wide range of attachment options and tilt angle adjustment
 - Ten mount holes (0.277" / 7.04 mm diameter) available on Universal Bracket base for permanent installation (see Figures 16 and 18 for details).

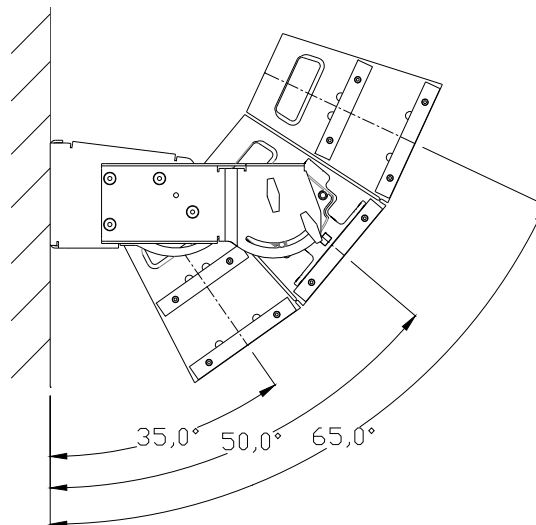

Figure 7: VT4886-UB in wall-mount mode

SPEAKER ATTACHMENT ADAPTER PLATE MOUNT PROCEDURE

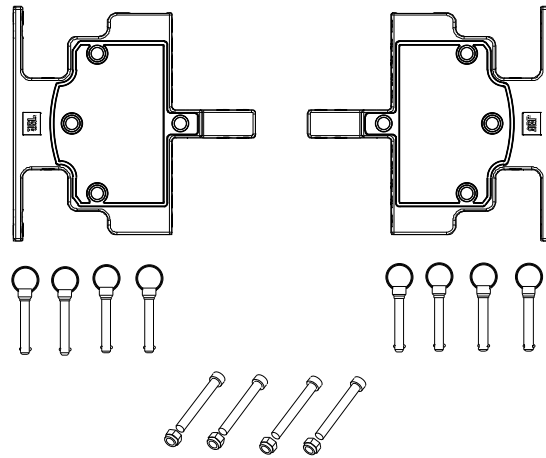

Figure 8: Left/Right Speaker Attachment Adapter Plates secure to VT4886 enclosure sides using supplied ball-lock pins. For suspended configurations or fixed installation, use #1/4-20 x 2" allen bolts and lock nuts for front attachment.



Remove all front and rear VT4886 quick release pins.

Store front VT4886 quick release pins in the interior holes available on Speaker Attachment Adapter Plate



Rotate the side adapter plate into position. Store rear VT4886 quick release pins in the available holes and secure Speaker Attachment Adapter Plates using the supplied ball lock pins.

Note: To allow attachment of additional enclosures, front and rear VT4886 hingebars should be extended prior to securing Speaker Attachment Adapter Plates



For suspension (under-balcony mode) or fixed installation, use supplied #1/4-20 x 2" allen head bolts and lock nuts for front attachment of Speaker Attachment Adapter Plates

Figure 9: Speaker Attachment Adapter Plate Mount Procedure

SPEAKER ATTACHMENT ADAPTER PLATE TO UNIVERSAL BRACKET BASE MOUNT PROCEDURE

Speaker Attachment Adapter Plates mount to the Universal Bracket using the supplied handles (2 per side). The pivot point on the Speaker Attachment Adapter Plate attaches to the A (lower) or C (upper) pivot attachment points on the Universal Bracket (no side extension plates) or pivot attachment point E when side extension plates are used. Three hole positions are available on the Speaker Attachment Adapter Plate that align with angle adjustment slots on the Universal Bracket Base (B or D) or Side Extension Plates (F). The range of tilt adjustment for various attachment options is summarized in Tables 1 and illustrated in Figure 12.

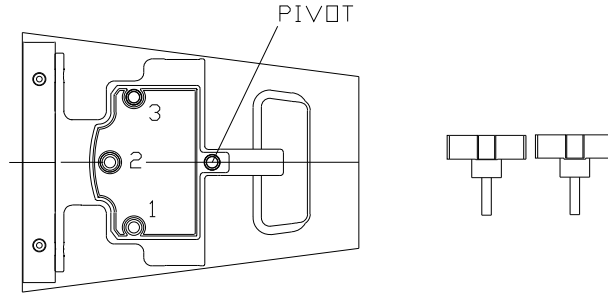

Figure 10: Speaker Attachment Adapter Plate detail showing pivot location and angle adjustment hole positions (1, 2, 3). Speaker Attachment Adapter Plates mount to VT4886-UB using 2 handles per side.

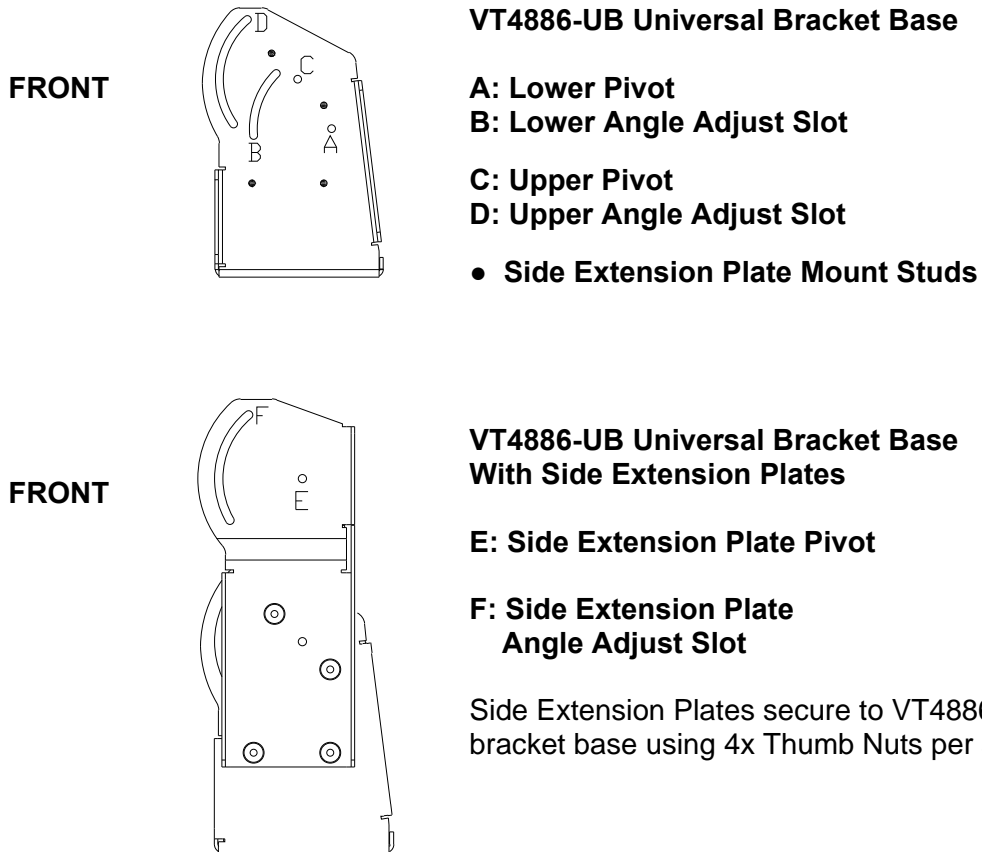

Figure 11: Universal Bracket Side Attachment Details (with and without extension plates)

TABLE 1: TILT ANGLE SUMMARY

PIVOT POINT	ANGLE ADJUST	HOLE POSITION	YOKE / STACKED MODE		UNDERBALCONY / SUSPENDED MODE	
			LOWER TILT LIMIT	UPPER TILT LIMIT	UPPER TILT LIMIT *	LOWER TILT LIMIT
A	B	1	34.5 deg	60.0 deg	-34.5 deg	-60.0 deg
A	B	2	-6.0 deg	45.0 deg	6.0 deg	-45.0 deg
A	B	3	-12.0 deg	6.0 deg	12.0 deg	-6.0 deg
C	D	1	4.5 deg	90.0 deg	-4.5 deg	-90.0 deg
C	D	2	-36.0 deg	51.0 deg	36.0 deg	-51.0 deg
C	D	3	-37.5 deg	11.0 deg	37.5 deg	-11.0 deg
E	F	1	10.0 deg	90.0 deg	-10.0 deg	-90.0 deg
E	F	2	-31.0 deg	51.0 deg	31.0 deg	-51.0 deg
E	F	3	-55.0 deg	11.0 deg	55.0 deg	-11.0 deg

NOTE: all angles with respect to horizontal (positive = upwards tilt, negative = downwards tilt)

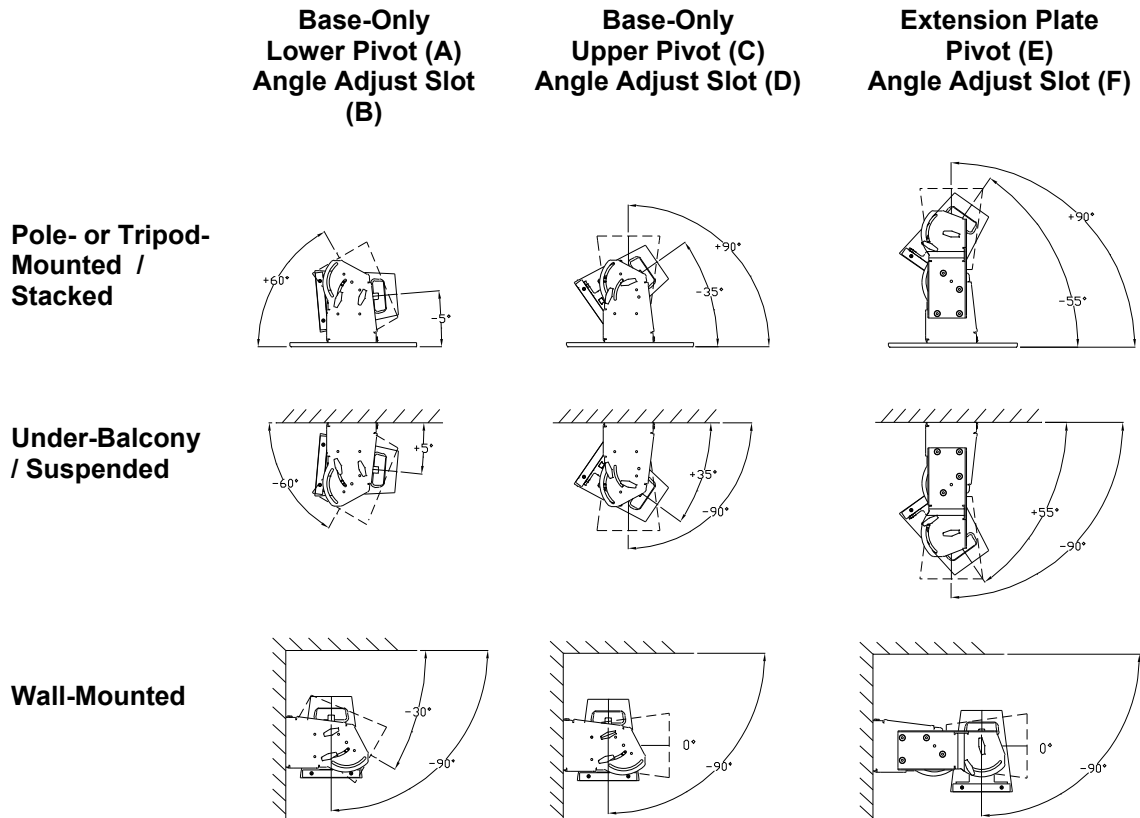

Figure 12: Maximum and Minimum Tilt Angles - Illustrated

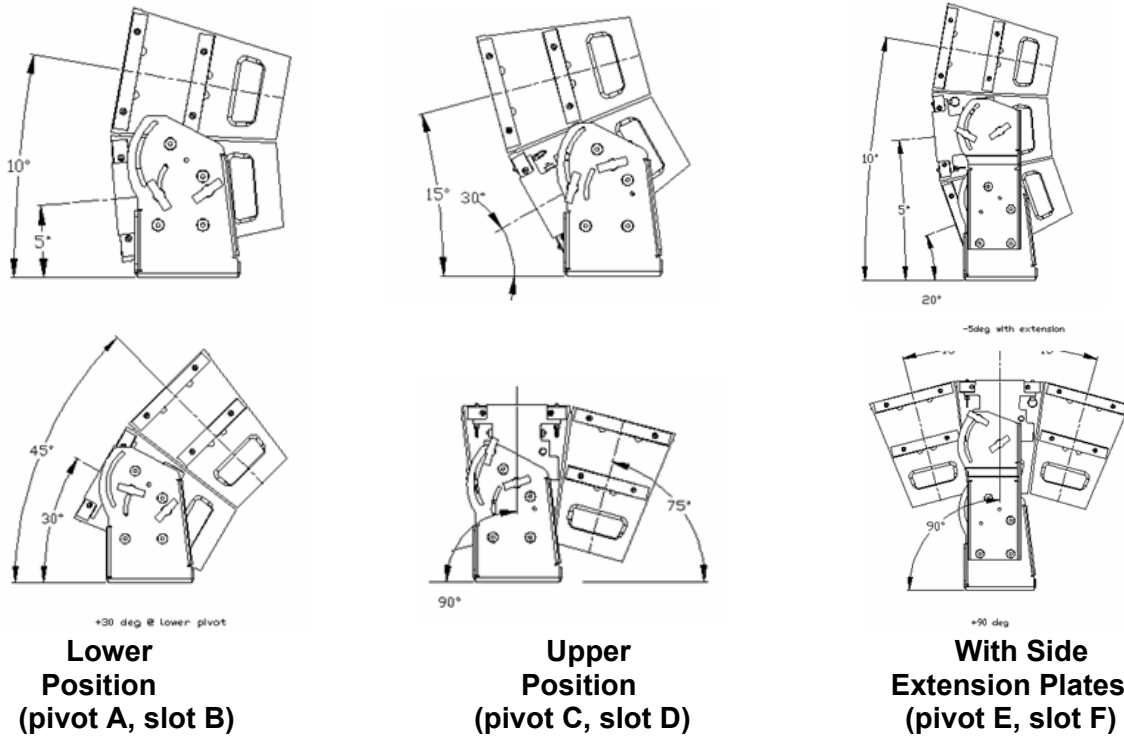

Figure 13: VT4886-UB Yoke Mode Examples (3 maximum : tripod-mounted, pole-mounted or omnimount)

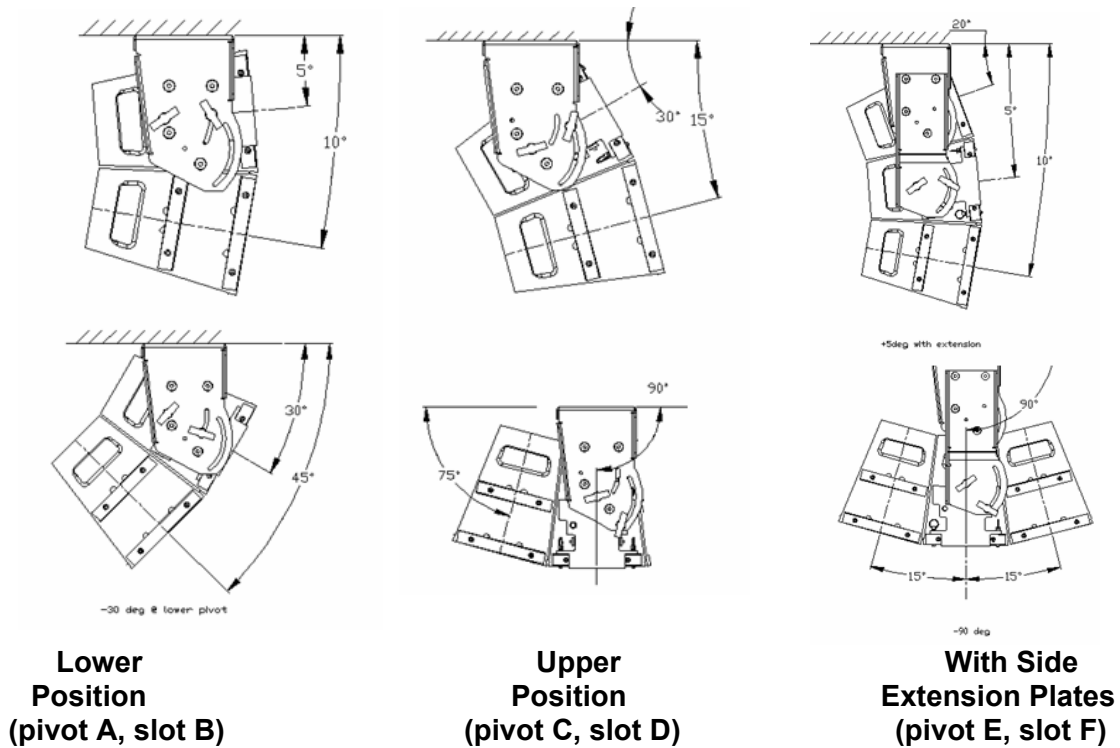

Figure 14: VT4886-UB Underbalcony Mode Examples (refer to Figures 16 and 18 for mounting options)
Also for use with 3rd party drop-down extension rod and pipe clamp accessories

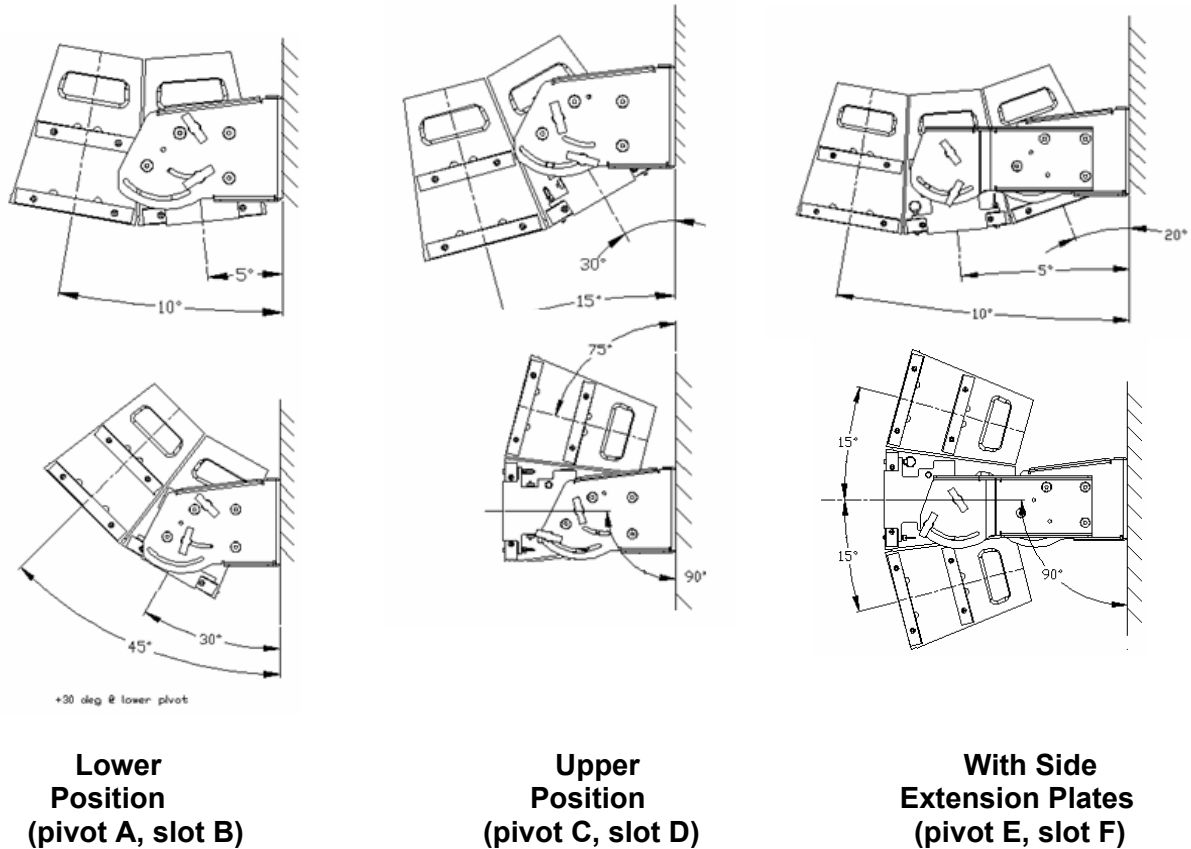
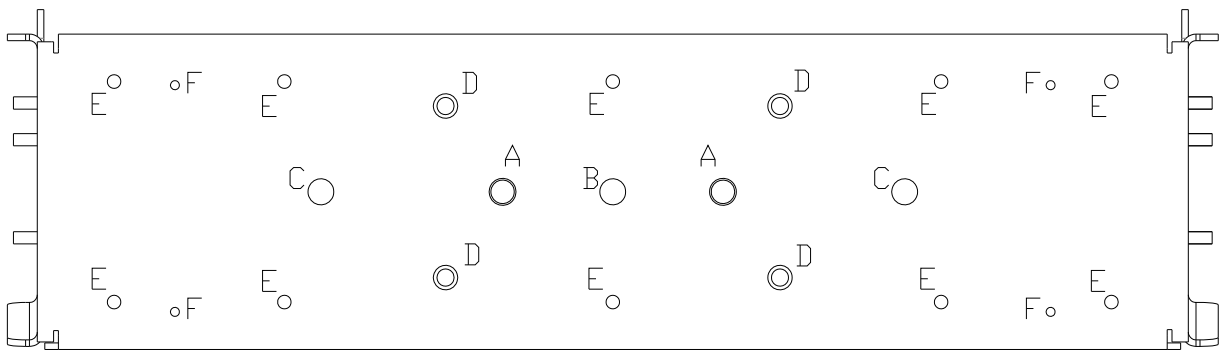

Figure 15: VT4886-UB Wall Mount Mode Examples (refer to Figures 16 and 18 for mounting options)



- A: POLE MOUNT ADAPTER (2x M10 threaded inserts)
- B: DROP-DOWN EXTENSION ROD – not supplied (1x 0.531 in / 13.5 mm diameter)
- C: EYEBOLTS – not supplied (2x 0.531 in / 13.5 mm diameter)
- D: OMNIMOUNT – not supplied (standard hole pattern, 4x 3/8 in x 16 threaded inserts)
- E: WALL OR CEILING MOUNT (10x 0.277 in / 7.04 mm diameter – suitable for 1/4" hardware)
- F: STABILIZER LEG ATTACHMENT (#8-32 thread)

Figure 16: VT4886-UB Universal Bracket Base Attachment Options

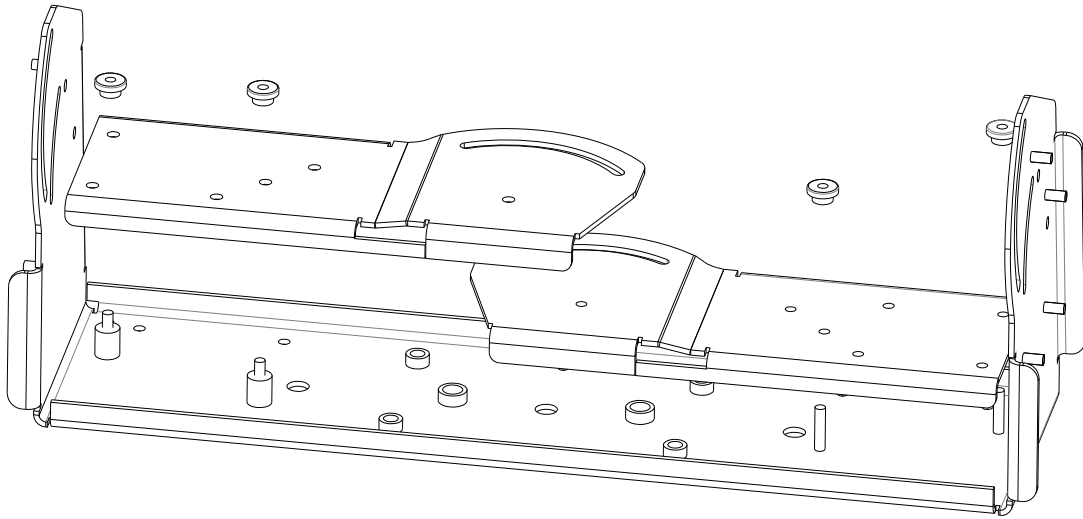

Figure 17: VT4886-UB Universal Bracket Side Extension Plate Storage Details

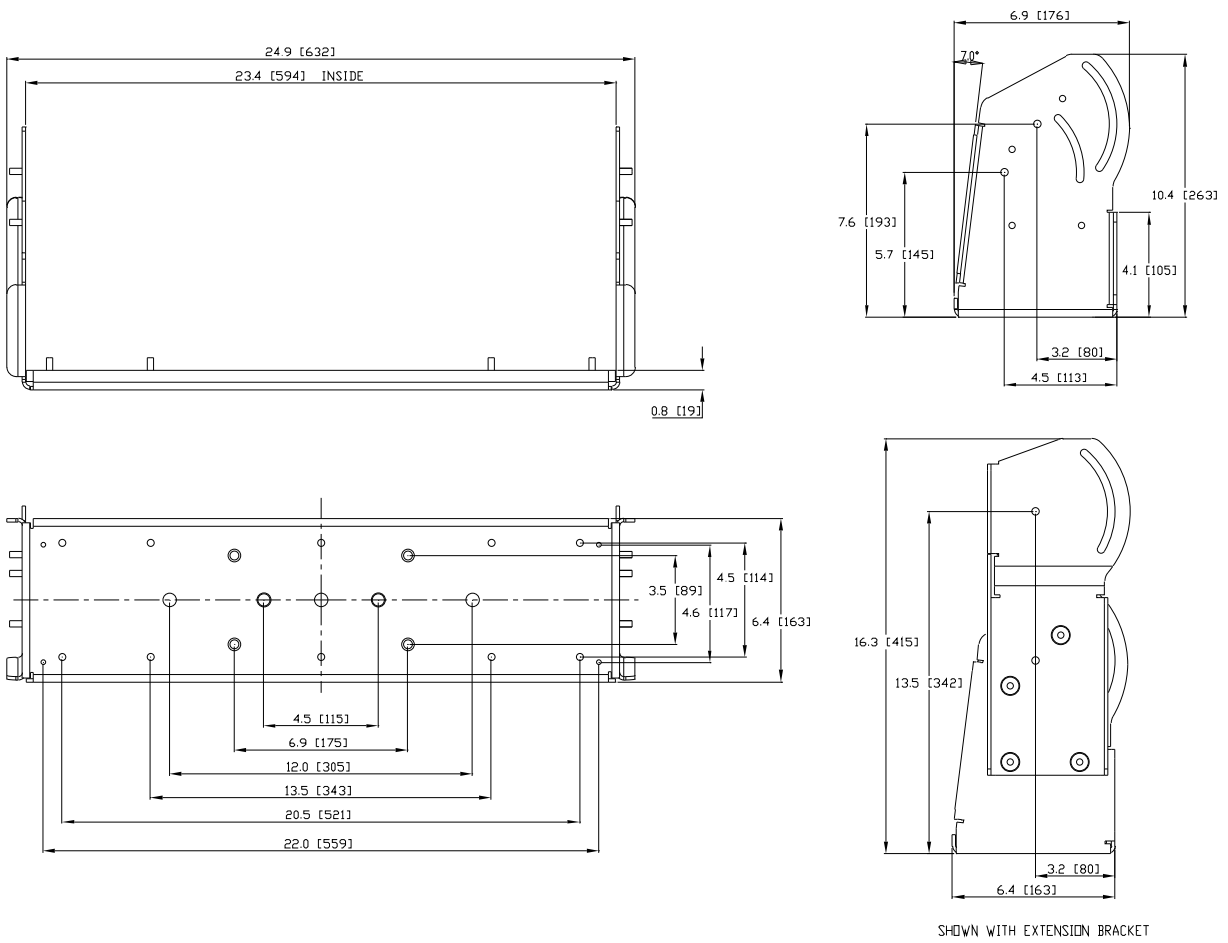

Figure 18: VT4886-UB Universal Bracket Dimensions

JBL WARRANTY AND INFORMATION

The JBL Warranty on professional loudspeaker products (except for enclosures) remains in effect for five years from the date of the first consumer purchase. JBL amplifiers are warranted for three years from the date of original purchase. Enclosures and all other JBL products are warranted for two years from the date of original purchase.

WHO IS PROTECTED BY THIS WARRANTY?

Your JBL Warranty protects the original owner and all subsequent owners provided that:

A) Your JBL product has been purchased in the Continental United States, Hawaii or Alaska. (this Warranty does not apply to JBL products purchased elsewhere except for purchases by military outlets. Other purchasers should contact the local JBL distributor for warranty information); and B) The original dated bill of sale is presented whenever warranty service is required.

WHAT DOES THE JBL WARRANTY COVER?

Except as specified below, your JBL Warranty covers all defects in material and workmanship. The following are not covered: Damage caused by accident, misuse, abuse, product modification or neglect; damage occurring during shipment; damage resulting from failure to follow instructions contained in your Instruction Manual; damage resulting from the performance of repairs by someone not authorized by JBL; claims based upon any misrepresentations by the seller; any JBL product on which the serial number has been defaced, modified or removed.

WHO PAYS FOR WHAT?

JBL will pay all labor and material expenses for all repairs covered by this warranty. Please be sure to save the original shipping cartons because a charge will be made if replacement cartons are requested. Payment of shipping charges is discussed in the next section of this warranty.

HOW TO OBTAIN WARRANTY PERFORMANCE

If your JBL product ever needs service, write or telephone us at JBL Incorporated (Attn: Customer Service Department), 8500 Balboa Boulevard, PO Box 2200, Northridge, California 91329 (818-893-8411). We may direct you to an authorized JBL Service Agency or ask you to send your unit to the factory for repair. Either way, you'll need to present the original bill of sale to establish the date of purchase. Please do not ship your JBL product to the factory without prior authorization. If transportation of your JBL product presents any unusual difficulties, please advise us and we may make special arrangements with you. Otherwise, you are responsible for transporting your product for repair or arranging for its transportation and for payment of any initial shipping charges. However, we will pay the return shipping charges if repairs are covered by the warranty.

Limitation Of Implied Warranties

ALL IMPLIED WARRANTIES INCLUDING WARRANTIES OF MERCHANTABILITY AND FITNESS FOR PARTICULAR PURPOSE, ARE LIMITED IN DURATION TO THE LENGTH OF THIS WARRANTY.

EXCLUSION OF CERTAIN DAMAGES

JBL'S LIABILITY IS LIMITED TO THE REPAIR OR REPLACEMENT, AT OUR OPTION, OF ANY DEFECTIVE PRODUCT AND SHALL NOT INCLUDE INCIDENTAL OR CONSEQUENTIAL DAMAGES OF ANY KIND. SOME STATES DO NOT ALLOW LIMITATIONS ON HOW LONG AN IMPLIED WARRANTY LASTS AND/OR DO NOT ALLOW THE EXCLUSION OF INCIDENTAL OR CONSEQUENTIAL DAMAGES, SO THE ABOVE LIMITATIONS AND EXCLUSIONS MAY NOT APPLY TO YOU. THIS WARRANTY GIVES YOU SPECIFIC LEGAL RIGHTS, AND YOU MAY ALSO HAVE OTHER RIGHTS, WHICH VARY, FROM STATE TO STATE.

CONTACT INFORMATION

Mailing Address:

JBL Professional
8500 Balboa Blvd.
Northridge, CA 91329

Shipping Address:

JBL Professional
Customer Service
8500 Balboa Blvd., Dock 15
Northridge, CA 91329
(Do not return product to this address without
first obtaining prior authorization from JBL)

Customer Service:

Monday through Friday
8:00am - 5:00pm
Pacific Coast Time In the U.S.A.
(800)8JBLPRO (800.852.5776)
www.jblproservice.com

On The World Wide Web:

www.jblpro.com
Professional Contacts, Outside The USA:
Contact the JBL Professional Distributor in your area. A
complete list of JBL Professional international distributors is
provided at our U.S.A. website www.jblpro.com

Product Registration:

Register your product online at www.jblpro.com/registration

EC-DECLARATION OF CONFORMITY



Brand: JBL Professional

Family Name: Vertec Series Suspension Hardware

Model Name: VT4800-CA, VT4800-DA, VT4800-UA, VT4886-AF, VT4886-UB, VT4887-AF, VT4887-SF, VT4888-AF, VT4888-SF, VT4889-AF, VT4889-SF

We, Harman International, declare under our sole responsibility that the product, to which this declaration relates, is in conformity with the following standards.

Standard	Description	Testing Agency
EC MACHINE DIRECTIVE 2006/42/EC SECTIONS 4.1.2.3 & 4.1.2.5	MACHINE DIRECTIVE – Applies to machinery and lays down essential health and safety requirements	Tested at JBL

Copies of all Technical Data, Safety Data and EMC reports can be obtained by contacting Frank Lacelle at frank.lacelle@harman.com.

JBL Professional, part of the Harman International group of companies, declares that the products produced under the aforementioned brand names are designed and produced as professional audio speakers and therefore outside of the intended scope of the European Commission Regulation (EC) 1275/2008 of 17 December 2008 implementing Directive 2005/32/EC of the European Parliament and of the Council with regard to ecodesign requirements for standby and off mode electric power consumption of electrical and electronic household and office equipment.

<http://www.jblpro.com/catalog/support/getfile.aspx?docid=1528&doctype=3>

Harman International expects our suppliers and business partners to be aware of their obligations under REACH and expects any substances or products within the scope of REACH to be pre-registered before December 1, 2008. Given those conditions, our current products are exempt from REACH pre-registration and later registration activities. We provide separate E.U. Reduction of Hazardous Substances documentation for our RoHS compliant products.

<http://www.jblpro.com/catalog/support/getfile.aspx?docid=1529&doctype=3>

The WEEE directive (2002/96/EC) places an obligation on all EU-based manufacturers and importers to take-back electronic products at the end of their useful life. JBL, through it's agent, accepts its responsibility to finance the cost of treatment and recovery of redundant WEEE in accordance with the specific WEEE recycling requirements. All of our products are marked with the WEEE symbol; this indicates that this product must NOT be disposed of with other waste. Instead it is the user's responsibility to dispose of their waste electrical and electronic equipment by handing it over to an approved re-processor, or by returning it to JBL's agent for reprocessing. For more information about where you can send your waste equipment for recycling, please contact your local distributor.

<http://www.jblpro.com/catalog/support/getfile.aspx?docid=1527&doctype=3>

JBL Professional, Northridge CA. USA 05/18/2010
(Place and Date of issue)

Frank Lacelle Compliance Manager
(Name and function of authorized person)



JBL Professional
8500 Balboa Blvd.
Northridge, CA 91329 USA

Part Number: 444877-001